

NPSEC-93-012

523

# NAVAL POSTGRADUATE SCHOOL

## Monterey, California



Mathcad Computer Applications  
Predicting Antenna Parameters from  
Antenna Physical Dimensions and  
Ground Characteristics

by

Donald D. Gerry  
" "  
R. Clark Robertson

June 1993

Approved for public release; distribution unlimited.

FedDocs  
D 208.14/2  
NPS-EC-93-012

Prepared for: NAVMARINTCEN  
D1433  
4301 Suitland  
Washington D.C. 20395-5020

ad 001  
208.10/2:DPS-E1-93-012

**Naval Postgraduate School**  
Monterey, California 93943-5000

Rear Admiral T. A. Mercer  
Superintendent

H. Schull  
Provost

This report was funded by NAVMARINTCEN.

Reproduction of all or part of this report is authorized.

This report was prepared by:

# REPORT DOCUMENTATION PAGE

DUDLEY KNIGX LIBRARY  
 NAVAL POSTGRADUATE SCHOOL  
 MONTEREY, CA 93943-5001

Public reporting burden for this collection of information is estimated to average 1 hour per response, including the time for reviewing instructions, searching existing data sources, gathering and maintaining the data needed, and completing and reviewing the collection of information. Send comments regarding this burden estimate or any other aspect of this collection of information, including suggestions for reducing this burden, to Washington Headquarters Services, Directorate for Information Operations and Reports, 1215 Jefferson Davis Highway, Suite 1204 Arlington, VA 22202-4302 and to the Office of Management and Budget, Paperwork Reduction Project (0704-0188), Washington, DC 20503

1. AGENCY USE ONLY (Leave blank)		2. REPORT DATE Jun 93	3. REPORT TYPE AND DATES COVERED Interim Dec 92 - Jun 93	
4. TITLE AND SUBTITLE MATHCAD COMPUTER APPLICATIONS PREDICTING ANTENNA PARAMETERS FROM ANTENNA PHYSICAL DIMENSIONS AND GROUND CHARACTERISTICS			5. FUNDING NUMBERS	
6. AUTHOR(S) Gerry, Donald D. and R. Clark Robertson				
7. PERFORMING ORGANIZATION NAME(S) AND ADDRESS(ES) Naval Postgraduate School Monterey, CA 93943-5002			8. PERFORMING ORGANIZATION REPORT NUMBER NPSEC-93-012	
9. SPONSORING/MONITORING AGENCY NAME(S) AND ADDRESS(ES) NAVMARINTCEN DI433 4301 Suitland Washington, D.C. 20395-5020			10. SPONSORING/MONITORING AGENCY REPORT NUMBER	
11. SUPPLEMENTARY NOTES The views expressed in this report are those of the author and do not reflect the official policy or position of the Department of Defense or U.S. Government				
12a. DISTRIBUTION/AVAILABILITY STATEMENT Approved for public release; distribution is unlimited			12b. DISTRIBUTION CODE	
13. ABSTRACT (Maximum 200 words) This report provides the documentation for a set of computer applications for the evaluation of antenna parameters. The applications are written for the Mathcad personal computer software for various antenna types listed in the thesis index. Antenna dimensions and, in some cases, ground parameters are the only required inputs for each application. No new antenna parameter equations were developed as a part of this research. The chapters of this thesis are intended to provide Mathcad antenna application users with the background information necessary to readily use and interpret the software for each antenna type. Appendices are provided with examples of each antenna application. Each application has an introductory paragraph and a table of required inputs. The Mathcad software provides various numerical outputs and performance predictions, as well as a graphical representation of radiation patterns in the far-field. Mathcad application results are consistent with the predictions of applicable publications, as well as other antenna numerical analysis programs.				
14. SUBJECT TERMS Radiation Pattern, Radiated Power, Directivity, Gain, Polarization, Efficiency, Effective Height/Area, Bandwidth, Wavelength, Effective Isotropic Radiated Power, Input Impedance, Reflection Coefficient			15. NUMBER OF PAGES 271	
			16. PRICE CODE	
17. SECURITY CLASSIFICATION OF REPORT Unclassified	18. SECURITY CLASSIFICATION OF THIS PAGE Unclassified	19. SECURITY CLASSIFICATION OF ABSTRACT Unclassified	20. LIMITATION OF ABSTRACT UL	





## ABSTRACT

This report provides the documentation for a set of computer applications for the evaluation of antenna parameters. The applications are written for the Mathcad personal computer software for various antenna types listed in the thesis index. Antenna dimensions and, in some cases, ground parameters are the only required inputs for each application. No new antenna parameter equations were developed as a part of this research.

The chapters of this thesis are intended to provide Mathcad antenna application users with the background information necessary to readily use and interpret the software for each antenna type. Appendices are provided with examples of each antenna application. Each application has an introductory paragraph and a table of required inputs.

The Mathcad software provides various numerical outputs and performance predictions, as well as a graphical representation of radiation patterns in the far-field. Mathcad application results are consistent with the predictions of applicable publications, as well as other antenna numerical analysis programs.

## TABLE OF CONTENTS

I.	BACKGROUND AND PURPOSE.....	1
II.	INTRODUCTION.....	2
III.	THE HELICAL ANTENNA.....	4
IV.	THE BEVERAGE ANTENNA.....	17
V.	THE LOOP ANTENNA.....	32
	A. THE ELECTRICALLY SMALL LOOP.....	34
	B. THE ELECTRICALLY LARGE LOOP.....	45
VI.	THE BEDSPRING ANTENNA.....	52
VII.	THE SPIRAL ANTENNA.....	67
	A. THE PLANAR SPIRAL ANTENNAS.....	67
	B. THE CONICAL SPIRAL ANTENNAS.....	80
VIII.	THE CONICAL HORN ANTENNA.....	93
IX.	THE PYRAMIDAL HORN ANTENNA.....	104
X.	REMARKS AND CONCLUSIONS.....	113
APPENDIX A	THE HELICAL ANTENNA, MATHCAD SOFTWARE HELIX.MCD...	115
APPENDIX B	THE BEVERAGE ANTENNA, MATHCAD SOFTWARE-BEVERAGE.MCD .....	125
APPENDIX C	THE SMALL LOOP ANTENNA, MATHCAD SOFTWARE-SMLOOP.MCD .....	135
APPENDIX D	THE LARGE LOOP ANTENNA, MATHCAD SOFTWARE-LGLOOP.MCD .....	168
APPENDIX E	THE BEDSPRING ANTENNA, MATHCAD SOFTWARE-BEDSPRIN.MCD .....	191
APPENDIX F	THE SPIRAL ANTENNA (EXACT METHOD), MATHCAD SOFTWARE- SPIRAL.MCD .....	206

APPENDIX G	THE CONICAL HORN ANTENNA (EXACT METHOD), MATHCAD	
	SOFTWARE-HORN_CON.MCD.....	231
APPENDIX H	THE PYRAMIDAL HORN ANTENNA, MATHCAD SOFTWARE-HORN_	
	PYR.MCD.....	237
REFERENCES.....		263
INITIAL DISTRIBUTION LIST.....		265



## I. BACKGROUND AND PURPOSE

This report and associated Mathcad computer software are submitted in partial fulfillment of the thesis requirements for the degree of Master of Science in Electrical Engineering from the Naval Postgraduate School in Monterey, CA.

The thesis requirement was generated by a statement of work from the Naval Maritime Intelligence Center (NAVMARINTCEN) such that any IBM compatible personal computer with MS-DOS version 3.2 or higher and a math coprocessor could run Mathcad software applications to analyze the parameters of different antenna types requested by NAVMARINTCEN.

Required user inputs to the applications are limited to antenna dimensions and ground data, although in some cases other data may be estimated to provide further insight into the antenna's performance. The Mathcad applications provide various performance predictions as well as a graphical representation of the antenna's far-field radiation pattern. The corresponding thesis chapter furnishes the application user all the necessary background information needed to interpret the program's formulas and displays, thereby allowing NAVMARINTCEN to interpret the capabilities and limitations of antennas of interest.

Dietrich [Ref 1.] completed the first portion of this project. This thesis will be the second in a series of three reports intended to fulfill the NAVMARINTCEN statement of work.



## II. INTRODUCTION

When a foreign country develops a new communications or radar system there are many reasons why various United States agencies may want to be appraised of the new equipment's capabilities and limitations. Indeed, if the country is hostile to the United States, the need for rapid threat analysis can be urgent. Unfortunately, without some human intelligence or other highly classified source data, input to any threat analysis is constrained to dimensional information gained from photographs of the equipment's antennas. In the past, intelligence agencies analyzing each new system on a case by case basis found this process to be very slow, tedious, and man power intensive.

With the advent of powerful personal computers and the availability of sophisticated mathematics software, antenna analysis using data obtained from photographic intelligence may now be achieved in a rapid manner. The goal of this report is to document the software developed to accomplish this type of performance appraisal. With this report and its programs, NAVMARINTCEN is supplied with a user friendly tool to aid in their task of antenna system evaluation.

It should be recognized that computer analysis of antenna parameters has its limitations. For example, it is impossible to account for the effects of adjacent structures on far-field radiation patterns and still keep the Mathcad applications moderately simple. In addition, without knowledge of parameters such as feed line characteristic impedance and antenna materials,

it is impossible to precisely assess the efficiency, gain, and radiated power of any antenna. Nevertheless, in most cases this report should provide the tools necessary to gain an excellent initial insight into the capabilities of systems which use the antenna types considered herein.

Each chapter of this report reviews a specific type of antenna and is written as a comprehensive reference for the software. Copies of each application are included as appendices to provide the user with a printed illustration of the software.

### III. THE HELICAL ANTENNA

The helical antenna is a wideband, highly directional device when operated in the axial radiation mode. It is commonly used in satellite and communications systems. To implement the Mathcad software for the helical antenna the following dimensions are needed:

D = diameter of helix (center to center of the conductor)

S = turn spacing (center to center of the conductor)

L = length of one turn

n = number of turns

d = diameter of helix conductor

C = circumference of the helix =  $\pi D^*$

$\alpha$  = pitch angle =  $\tan^{-1}(S/\pi D)^*$

The first four dimensions are application inputs, the \* indicates that the remaining two parameters are calculated by the helical antenna Mathcad application. The helical antenna geometric relationships are illustrated in Figures 3.1 and 3.2.

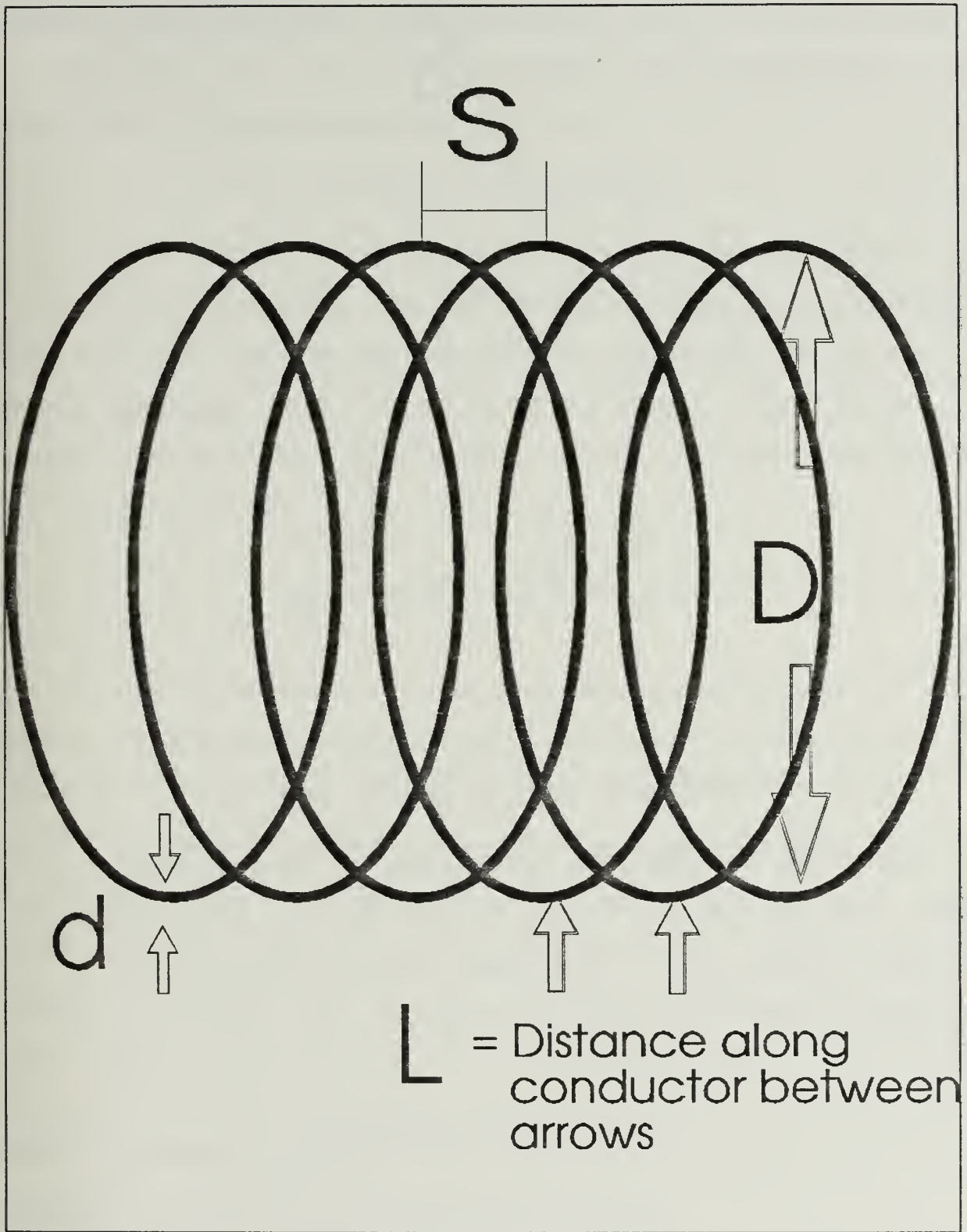

FIGURE 3.1 Helix Dimensions

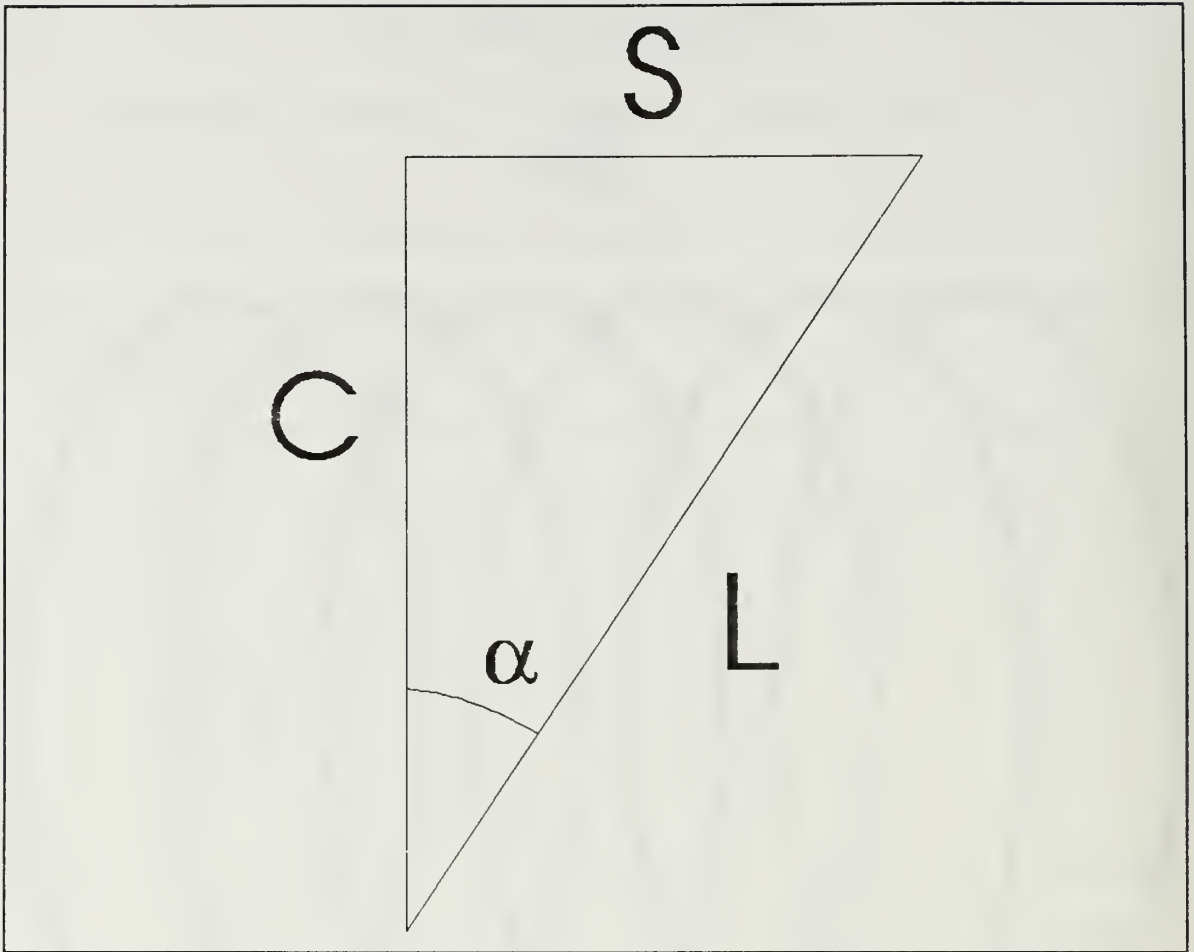

FIGURE 3.2 Pitch Angle of a Helix

The axial mode helical antenna has a highly directive main lobe, negligible mutual impedance with adjacent antennas, a low voltage standing wave ratio (VSWR), and a resistive input impedance if the following conditions are met [Ref 2: pp. 277-288]:

$$.8 \leq C_\lambda \leq 1.15 \quad (\text{wavelengths}) \quad (3.1)$$

$$n > 3 \quad (\text{turns}) \quad (3.2)$$

$$12^\circ \leq \alpha \leq 14^\circ \quad (\text{degrees}) \quad (3.3)$$



Subscripts containing ( $\lambda$ ) indicate the dimension in wavelengths.

Assuming (3.1) - (3.3) are satisfied, one can estimate directivity ( $D_0$ ) as follows:

$$D_0 \approx 12 C_\lambda^2 n S_\lambda \quad (\text{dimensionless}) \quad (3.4)$$

For a long helix ( $n S_\lambda \geq 1$ ), the relative phase velocity of the traveling wave ( $p$ ) is the key variable for calculating far-field radiation patterns and associated parameters. Although several equations can be used for determining relative phase velocity, the one which most closely matches measured results is [Ref 2: pp. 288-300]:

$$p = \frac{L_\lambda}{S_\lambda + m + (1/2n)} \quad (\text{dimensionless}) \quad (3.5)$$

In (3.5), ( $m$ ) corresponds to the transmission mode number of the antenna. The transmission mode is a term used to describe the manner in which an electromagnetic wave propagates down the helix. The number assigned to a given transmission mode ( $T_m$ ) is an integer. When  $m = 0$  the helix radiates in what is termed the normal mode, since the main lobe is perpendicular to the axis of the helix. In some texts a helical antenna which radiates in the normal mode is called an electrically small antenna. The normal mode is not commonly used and will not be covered further in this report. The Mathcad applications analyze only the non-zero transmission modes of a given helical antenna.

The mode of a helix is determined by its physical size, with higher modes corresponding to larger antennas. The relationship

between helix circumference and spacing for  $m = 1, 2$  is illustrated in Figure 3.3.

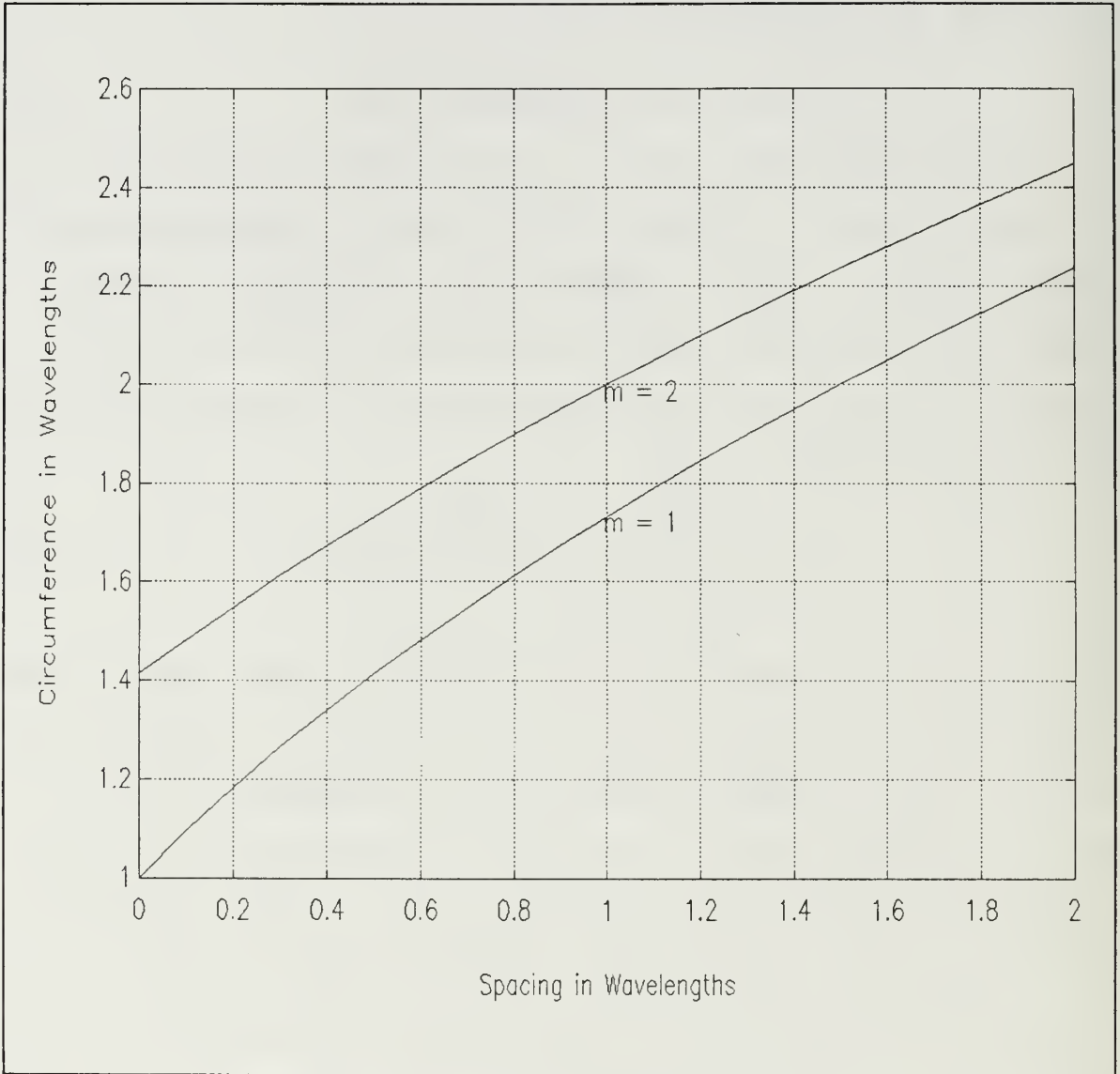

FIGURE 3.3 Helix Mode Chart

The general relationship between helical radiation mode, turn length, circumference, and spacing is provided in the following equations [Ref 2: p. 289]:

$$L^2 = C^2 + S^2 \quad (3.7)$$

$$\frac{L_\lambda}{p} = S_\lambda + m \quad (3.6)$$

Once the relative phase velocity has been determined and a transmission mode is selected, it is possible to resolve the far-field radiation pattern of the helix. As long as the helix is long, it can be regarded as an array consisting of (n) one turn loops. To begin radiation pattern computations the phase shift ( $\psi$ ) of each equivalent point source in the effective array factor of the helix is computed as follows:

$$\psi = 2\pi \left( S_\lambda \cos\theta - \frac{L_\lambda}{p} \right) \quad (\text{radians}) \quad (3.8)$$

In (3.8), ( $\theta$ ) corresponds to the coaltitude, or deflection angle from the axis of the helix.

As a result of the symmetrical nature of a helical antenna's main lobe the following relation holds:

$$E_\theta \approx jE_\phi \quad (V/m) \quad (3.9)$$

The far-field radiation pattern of a single helical turn is reasonably estimated by  $\cos(\theta)$ . The electric field pattern (E) is given by the product of the array factor and the individual turn's pattern. As predicted by the principle of pattern multiplication, the array factor corresponding to an array of isotropic point sources dominates the field pattern generated by a single turn of the helix. This effect can be seen in the following formula for electric field [Ref 2: pp. 294-295]:

It should be noted that unless the helix is very short ( $nS_\lambda$

$$E = \sin \frac{\pi}{2n} \left( \frac{\sin \frac{n\Psi}{2}}{\sin \frac{\Psi}{2}} \right) \cos \theta \quad (V/m) \quad (3.10)$$

< .5), ground plane reflections and their effects on electric field patterns for the antenna are negligible. Consequently, ground parameters are not required for this application.

The radiation intensity (U) at any far-field observation point is a function of  $E_\theta$  and  $E_\phi$  per the following equation [Ref 3: pp. 28-29]:

$$U = \frac{1}{2\eta_o} [ |E_\theta|^2 + |E_\phi|^2 ] \quad (W/solid\ ang) \quad (3.11)$$

From (3.9), (3.11) can be reduced to:

$$U = \frac{1}{\eta_o} |E|^2 \quad (W/solid\ ang) \quad (3.12)$$

In (3.11) and (3.12), ( $\eta_o$ ) is the intrinsic impedance of free space.

The average radiated power ( $P_{rad}$ ) for any antenna is given by:

$$P_{rad} = \iint_{\Omega} U d\Omega = \int_0^{2\pi} \int_0^{\pi} U \sin \theta d\theta d\phi \quad (W) \quad (3.13)$$

In (3.13), ( $\Omega$ ) is a sphere in the far-field surrounding the antenna.

It is impossible to determine total efficiency ( $\epsilon_t$ ) of the helical antenna based only on dimensional information. Therefore, an antenna's gain (G) cannot be precisely determined using the following general gain formula:

$$G = \epsilon_r D_o \quad (\text{dimensionless}) \quad (3.14)$$

However, a unique feature of helical antennas is that input impedance ( $Z_i$ ) is essentially equal to input resistance ( $R$ ) when (3.1) - (3.3) are satisfied. Fortunately, the input resistance of the helical antenna can be calculated with observed measurements by [Ref 2: pp 277-278]:

$$\text{Axial Feed: } R = 140 C_\lambda \quad (\Omega) \quad (3.15)$$

$$\text{Peripheral Feed: } R = \frac{150}{\sqrt{C_\lambda}} \quad (\Omega) \quad (3.16)$$

If antenna feed characteristic impedance ( $Z_o$ ) is known or can be estimated, then reflection efficiency ( $\epsilon_r$ ) can be computed from the voltage reflection coefficient ( $\Gamma$ ) by [Ref 4: p. 460]:

$$\Gamma = \frac{R - Z_o}{R + Z_o} \quad (\text{dimensionless}) \quad (3.17)$$

$$\epsilon_r = 1 - |\Gamma|^2 \quad (\text{dimensionless}) \quad (3.18)$$

Although (3.17) and (3.18) provide an estimate of reflection efficiency, no other helical antenna efficiency terms can be determined based on geometry alone. Thus, all other components of total efficiency are assumed to be unity and gain is expressed as:

$$G = \epsilon_r D_o \quad (\text{dimensionless}) \quad (3.19)$$

EIRP is a commonly used term from communications that is formally defined as the product of antenna gain and total power



accepted by the antenna from the transmitter. EIRP is determined as follows [Ref 5: p. 62]:

$$EIRP = P_{rad} D_o \quad (W) \quad (3.20)$$

A functional helical antenna will exhibit nearly circular polarization when (3.1) - (3.3) are satisfied. Axial ratio (AR) provides a figure of merit for circular polarization in that if it is equal to unity the polarization of the antenna is exactly circular. The further axial ratio is from one, the more elliptically polarized the helical wave will be. The axial ratio of a helix is [Ref 2: pp. 301-307]:

$$AR = |L_\lambda (\sin(\alpha) - 1/p)| \quad (dimensionless) \quad (3.21)$$

The helical antenna's unit polarization vector ( $\sigma_a$ ) at a given point in the far-field is computed using the Cartesian components of electric field. The Cartesian components of electric field and the antenna's unit polarization vector are determined using the results of (3.9) and (3.10) as follows [Ref 5: p. 555]:

$$E_x = E_\theta \cos(\theta) \cos(\phi) - E_\phi \sin(\phi) \quad (V/m) \quad (3.22)$$

$$E_y = E_\theta \cos(\theta) \sin(\phi) + E_\phi \cos(\phi) \quad (V/m) \quad (3.23)$$

$$E_z = -E_\theta \sin(\theta) \quad (V/m) \quad (3.24)$$

$$\vec{\sigma}_a(x, y, z) = \frac{\vec{a}_x E_x + \vec{a}_y E_y + \vec{a}_z E_z}{\sqrt{|E(x, y, z)|^2}} \quad (dimensionless) \quad (3.25)$$

In (3.25), ( $\vec{a}_{x,y,z}$ ) are the Cartesian unit vectors.

When the helical antenna is used for reception and the incoming wave's electric field unit vector ( $\rho_w$ ) at a given point in the far-field is known or can be estimated, the polarization loss factor (PLF) is given by [Ref 3: p. 51]:

$$PLF = |\bar{\sigma}_w \bar{\sigma}_a^*|^2 \quad (\text{dimensionless}) \quad (3.26)$$

The term which best describes an antenna's ability to capture incoming electromagnetic waves and extract power from them is maximum effective aperture ( $A_{em}$ ). Maximum effective aperture for a helical antenna is [Ref 3: p. 63]:

$$A_{em} = [PLF] \left[ \epsilon_r \frac{\lambda^2}{4\pi} D_o \right] \quad (m^2) \quad (3.27)$$

In (3.27), ( $\lambda$ ) is wavelength of the frequency ( $f$ ) of interest.

Although the current ( $I_o$ ) at the terminals of the helical antenna cannot be determined from dimensional information alone, if the current is assumed to be unity the radiation resistance ( $R_r$ ) and maximum effective height ( $h_{em}$ ) are estimated by [Ref 2: p. 42]:

$$R_r = \frac{2P_{rad}}{|I_o|^2} \quad (\Omega) \quad (3.28)$$

$$h_{em} = 2 \sqrt{\frac{R_r A_{em}}{\eta_o}} \quad (m) \quad (3.29)$$

Helical antenna Mathcad applications are valid for conductor diameters given by:

$$.005\lambda \leq d \leq .05\lambda \quad (m) \quad (3.30)$$

The bandwidth (BW) of an operational helix is determined by the high and low frequencies ( $f_{high}$ ,  $f_{low}$ ) corresponding to the dimensional limits of (3.1). Therefore, bandwidth can be calculated using the speed of light ( $c$ ) by:

$$f_{high} = \frac{1.15c}{C} \quad (Hz) \quad (3.31)$$

$$f_{low} = \frac{.8c}{C} \quad (Hz) \quad (3.32)$$

$$BW = f_{high} - f_{low} \quad (Hz) \quad (3.33)$$

Most of the parameters calculated by the Mathcad helical antenna applications are only valid if the observation point ( $r$ ) is in the far-field. An observation point is considered to be in the far-field if all of the following are satisfied [Ref 3: p. 92]:

$$r \geq 1.6\lambda \quad (m) \quad (3.34)$$

$$r \geq 5nS \quad (m) \quad (3.35)$$

$$r \geq \frac{2(nS)^2}{\lambda} \quad (m) \quad (3.36)$$

Table 3.1 and Figure 3.4 compare measured data to that calculated by the Mathcad applications for a 10 turn helical antenna ( $D = .1074$  meters and  $\alpha = 12.8^\circ$ ) [Ref 6: 13-6 - 13-9].

TABLE 3.1 Helical Antenna Data Comparison

ANTENNA PARAMETER	MEASURED DATA	CALCULATED DATA
HALF-POWER BEAMWIDTH	39°	37°
GAIN	12.5 dB	14.3 dB

### Comparison of Helical Antenna Electric Fields

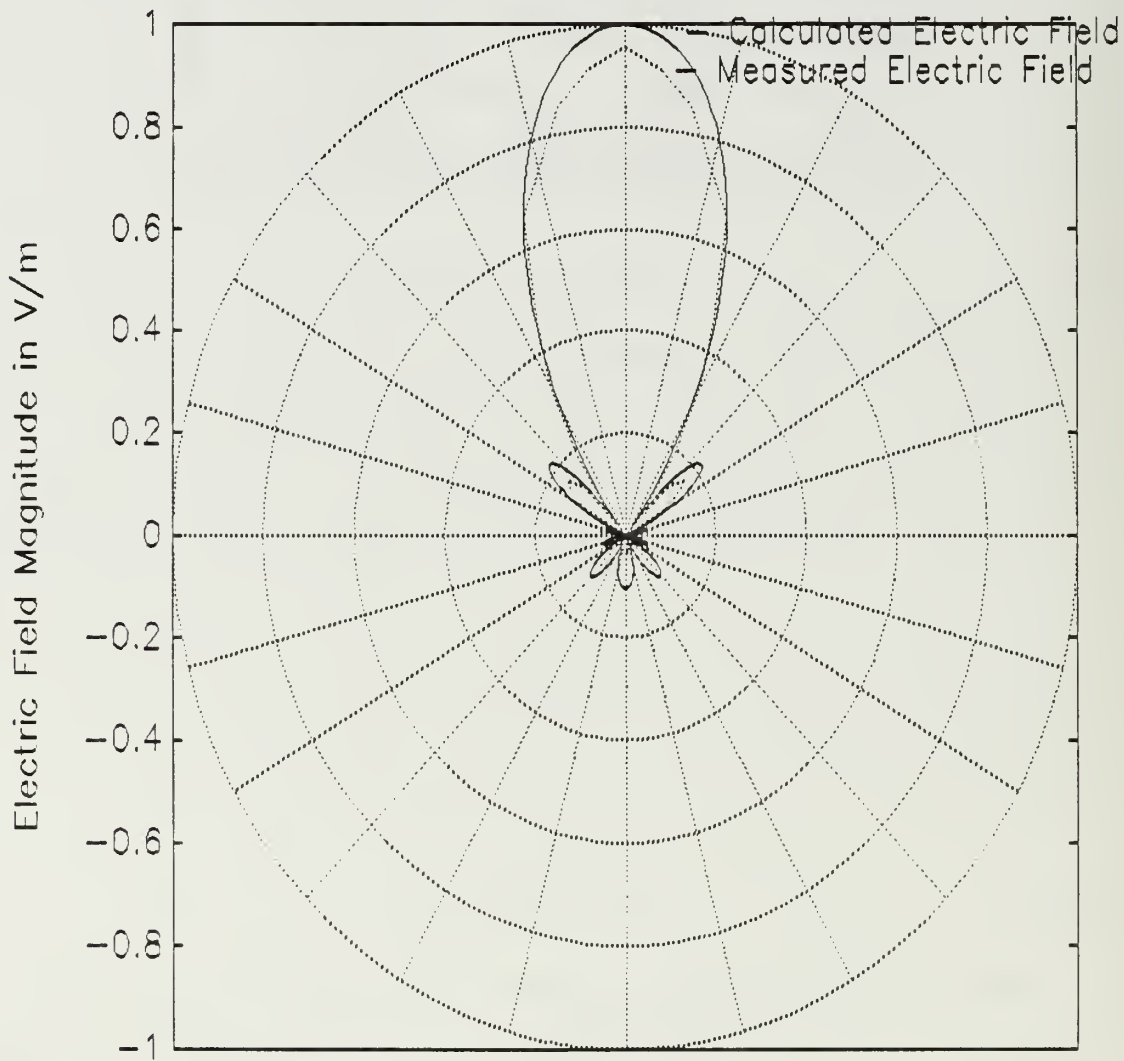

FIGURE 3.4 Helical Antenna Electric Field Pattern



#### IV. THE BEVERAGE ANTENNA

The Beverage antenna is a single wire antenna parallel to the ground and terminated with a load equal to the characteristic impedance ( $Z_0$ ) of the wire. The transmitter or receiver of a Beverage antenna has one end connected to the wire and the other to ground. Because of its matched termination, the Beverage antenna does not develop a significant standing voltage wave along its length. Therefore, it is known as a traveling wave antenna. The relative phase velocity ( $\beta$ ) of the wave traveling down the antenna is typically less than one. Thus, the Beverage antenna is also considered a slow wave antenna. [Ref 3: pp.372-374]

Although radiation can occur at any non-uniformities in the device, the Beverage antenna primarily generates a vertically polarized cone shaped main beam that points in the direction of the traveling wave. The geometry of a Beverage antenna is illustrated in Figures 4.1 and 4.2.

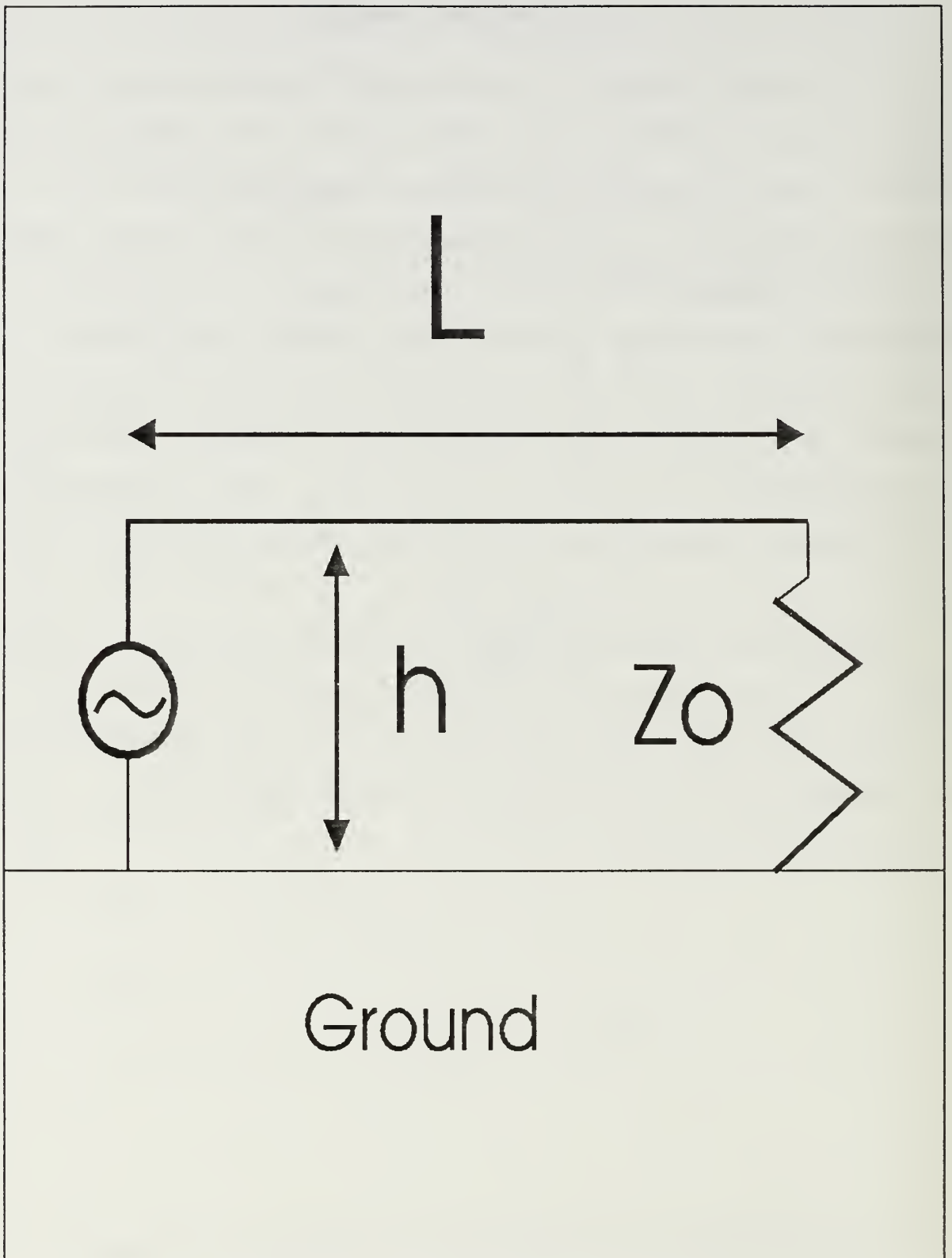

FIGURE 4.1 The Beverage Antenna

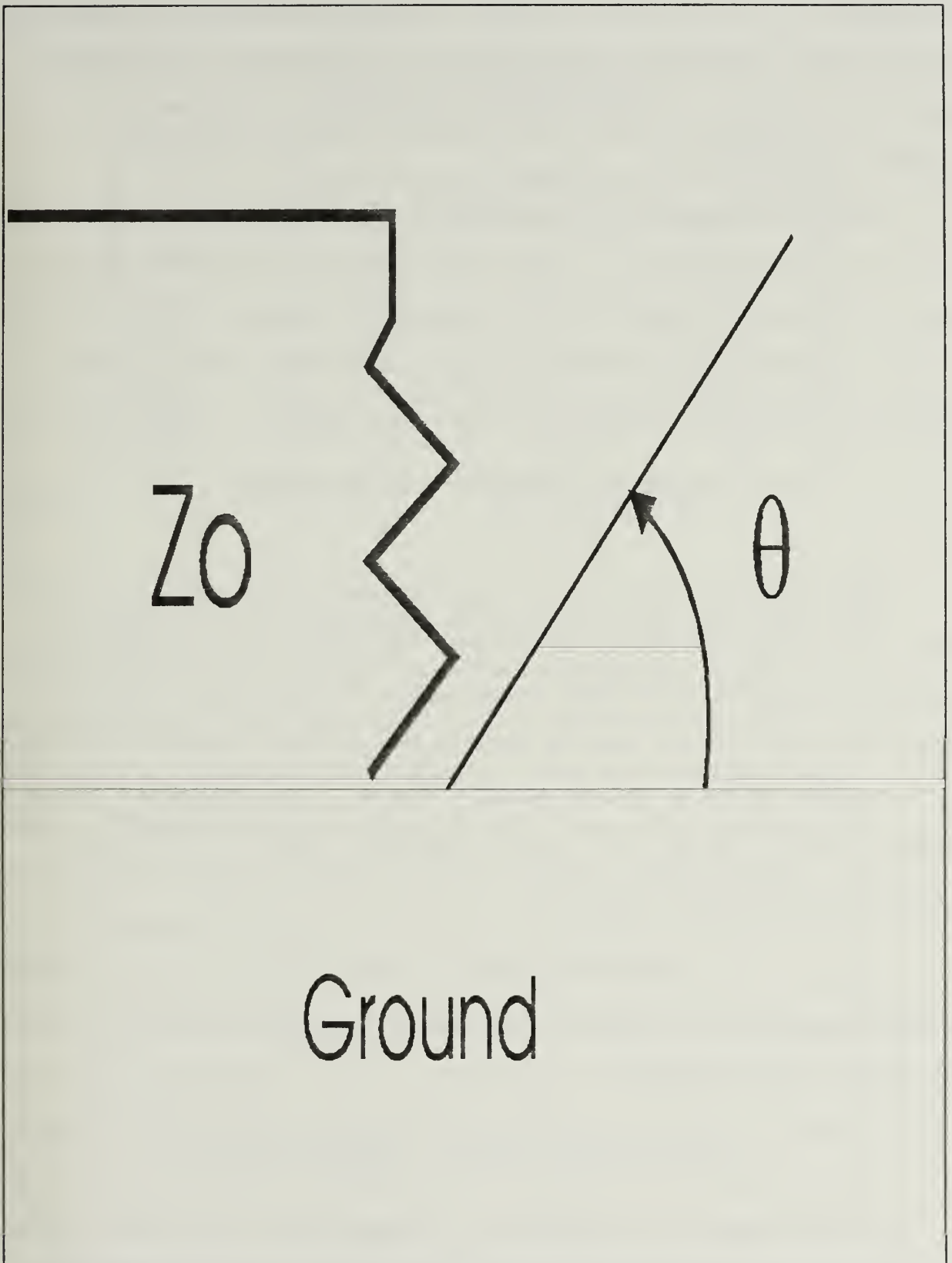

FIGURE 4.2 Elevation Angle ( $\theta$ ) of a Beverage Antenna

In Figure 4.1, (h) is the antenna's height above ground and (L) is the total length of the antenna. In Figure 4.2, ( $\theta$ ) is the angle of incidence of an incoming or transmitted wave with respect to ground.

Typically, the electrical length of a Beverage antenna ( $L_\lambda$ ) will be on the order of 0.5 to 2 wavelengths. Maximum length ( $L_{\lambda\max}$ ) at which the antenna is expected to operate is a function of both arrival angle of the incoming wave and relative phase velocity. A precise formula for maximum length is [Ref 7: p. 14]:

$$L_{\lambda\max} = \frac{1}{4 \left( \frac{1}{p} - \cos(\theta) \right)} \quad (\text{wavelengths}) \quad (4.1)$$

Unfortunately, use of (4.1) is normally not possible. The wave's angle of incidence is always changing and can only be estimated using statistical techniques. In addition, relative phase velocity is not easily determined by the antenna's geometry and, consequently is not generally known. Some relative phase velocity measurements have been conducted over the following frequency band [Ref 7: p. 19]:

$$1.6 \text{ MHz} \leq f \leq 10.5 \text{ MHz} \quad (\text{Hz}) \quad (4.2)$$

If the frequency of interest meets the criteria of (4.2), then (p) can be computed by:

$$p = .65891 \left( \frac{f}{1000} \right)^{.038523821} \quad (\text{dimensionless}) \quad (4.3)$$

If inadequate information is available to use (4.1), the Beverage antenna application user can estimate maximum length

from Table 4.1 [Ref 7: p. 14].

**TABLE 4.1** Maximum Effective Length of a Beverage Antenna in Wavelengths

$\theta$ in deg	$L_{\lambda_{max}}$		
	$p=.89$	$p=.91$	$p=.93$
0	2.02	2.53	3.32
10	1.80	2.19	2.76
20	1.36	1.57	1.84
30	.97	1.07	1.19
40	.70	.75	.81
50	.52	.55	.58

Because of the difficulty determining ( $\theta$ ) and ( $p$ ), the Mathcad application assumes that the difference between frequencies corresponding to 0.5 to 2 wavelengths is the bandwidth for the Beverage antenna. The application also computes relative phase velocity per (4.3), but the user is cautioned that the frequencies of interest must satisfy (4.2).

The Beverage antenna transmits or receives vertically polarized waves. In the case of reception, the question might arise as to how a wire lying parallel to the ground can receive a vertically polarized signal. For higher frequency operations that utilize sky wave propagation, the tilt of the incoming wave provides a horizontal component of the vertically polarized electric field ( $E$ ) with respect to the ground and the antenna. It is the horizontal component of the wave that is parallel to

the antenna which generates the emf on the wire.

For lower frequencies (i.e.,  $< 300$  Khz), the physics of a Beverage antenna is much more complex. In lower frequency applications, the ground wave is the principle propagation path. In this situation there is negligible tilt to the wave as a result of propagation path geometry. However, as the vertically polarized wave travels over an imperfect conductor the electric field closest to ground begins to develop a forward tilt as pictured in Figure 4.3. As in the case of the higher frequency applications, the tilted electric field of the low frequency wave has a horizontal component parallel to the antenna which induces an emf on the wire.

Originally, use of the Beverage antenna was restricted to low frequencies propagating over very poor ground. The Beverage antenna is now often used in an attempt to reduce noise interference in high frequency operations over excellent ground. The higher frequency skywave propagation path provides the necessary tilt to receive vertically polarized signals, but the near perfect ground does tilt vertically polarized ground waves from nearby noise sources. Thus, the high frequency Beverage antenna becomes a highly directive, low noise device.

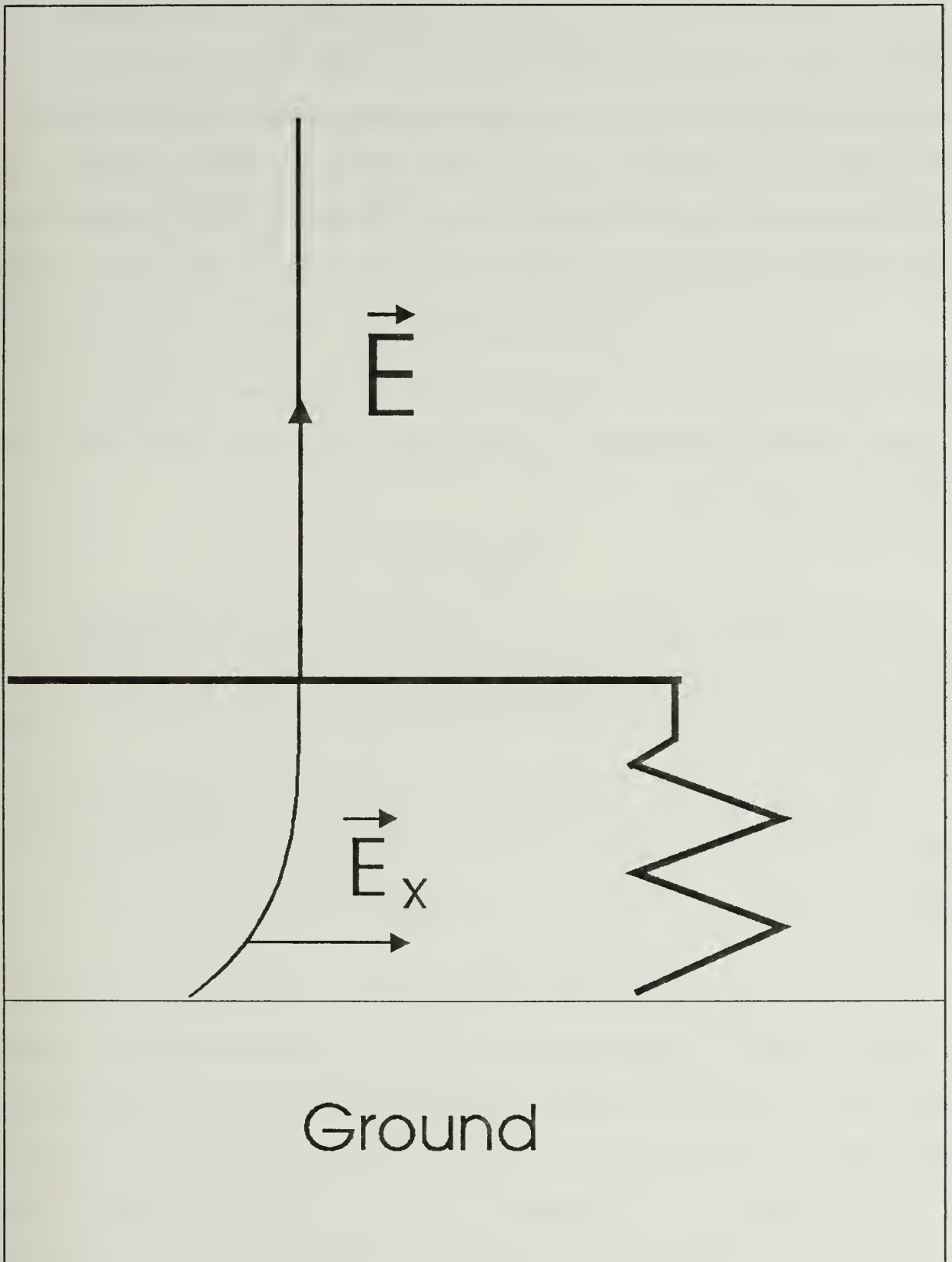

FIGURE 4.3 E Field Over an Imperfect Ground



Development of the electric field pattern of a Beverage antenna begins with an understanding of the current on the antenna. If one assumes low ohmic losses, matched termination, and negligible attenuation along the wire, the phasor current amplitude is constant and the phase velocity is that of free space; hence [Ref 5: p. 240]:

$$I(z) = I_0 e^{-jkz} \quad (A) \quad (4.4)$$

In (4.4) the antenna is assumed to lie along the +z axis, ( $I_0$ ) is current at the transmitter's terminals, and ( $k$ ) is the free space wavenumber given by:

$$k = \frac{2\pi}{\lambda} \quad (m^{-1}) \quad (4.5)$$

In (4.5), ( $\lambda$ ) is wavelength of the frequency ( $f$ ) of interest. Beverage antenna Mathcad applications assume ( $I_0$ ) is normalized to one amp.

With the current defined by (4.4) the magnitude of the Beverage antenna's electric field is obtained by [Ref 8: pp. 315-316]:

$$|E| = \frac{30kLI_0 \sin(\theta)}{r} \left| \frac{\sin(X)}{X} \right| \quad (V/m) \quad (4.6)$$

In (4.6), ( $r$ ) is the distance from the antenna to the far-field observation point,  $L$  is the length of the antenna, and ( $X$ ) is given by:

$$X = \frac{kL}{2} (1 - \cos(\theta)) \quad (\text{radians}) \quad (4.7)$$

The electric field pattern given by (4.6) is rotated about the +z axis to form the three-dimensional field pattern above the ground plane. The pattern is only valid, however, in the far-field. Therefore, all of the following conditions must be satisfied for (4.6) to apply [Ref 3: p. 92]:

$$r \geq 1.6\lambda \quad (m) \quad (4.8)$$

$$r \geq 5L \quad (m) \quad (4.9)$$

$$r \geq \frac{2L^2}{\lambda} \quad (m) \quad (4.10)$$

Improvements to the accuracy of (4.6) can be made for far-field radiation patterns if one accounts for the effects of real ground. Through use of image theory and the fact that Beverage antennas excite vertically polarized waves, the electric field pattern equation is modified as follows [Ref 5: pp. 229-235]:

$$E = \frac{30kLI_0 \sin(\theta)}{r} \left| \frac{\sin(X)}{X} \right| [1 - \Gamma_v e^{-j2kh \cos(\frac{\pi}{2} - \theta)}] \quad (V/m) \quad (4.11)$$

In (4.11),  $(\Gamma_v)$  is the vertical reflection coefficient of ground. Antenna height is typically less than one wavelength. The vertical reflection coefficient is given by:

In (4.12),  $(\epsilon_r)$  is the relative complex permittivity of the ground under the antenna and is calculated as follows:

In (4.13),  $(\epsilon_r)$  is the relative permittivity of the ground and

$$\Gamma_v = \frac{\epsilon_r \cos\left(\frac{\pi}{2} - \theta\right) - \sqrt{\epsilon_r - \sin^2\left(\frac{\pi}{2} - \theta\right)}}{\epsilon_r \cos\left(\frac{\pi}{2} - \theta\right) + \sqrt{\epsilon_r - \sin^2\left(\frac{\pi}{2} - \theta\right)}} \quad (\text{dimensionless}) \quad (4.12)$$

$$\epsilon_r = \epsilon_r - j \frac{\sigma}{2\pi f \epsilon_0} \quad (\text{dimensionless}) \quad (4.13)$$

( $\sigma$ ) is the conductivity of the ground.

The direction of maximum radiation of a Beverage antenna may be determined from (4.11). However, it can also be estimated quickly by the following empirical formula [Ref 5: p. 241]:

$$\theta_{\max} = \cos^{-1}\left(1 - \frac{.371}{\frac{L}{\lambda}}\right) \quad (\text{radians}) \quad (4.14)$$

With the magnitude of the vertically polarized electric field given by (4.11), radiation intensity is computed as follows [Ref 3: pp. 28]:

$$U = \frac{r^2}{2\eta_0} [|E|^2] \quad (W/\text{solid ang}) \quad (4.15)$$

In (4.15), ( $\eta_0$ ) is the intrinsic impedance of free space.

The radiated power and directivity of a Beverage antenna are determined by applying radiation intensity to standard antenna formulas as follows [Ref 3: pp. 28-30]:

$$P_{rad} = \int_0^\pi \int_0^\pi U \sin(\theta) d\theta d\phi \quad (W) \quad (4.16)$$

$$D_0 = \frac{4\pi U(\theta_{max})}{P_{rad}} \quad (dimensionless) \quad (4.17)$$

The characteristic impedance of a Beverage antenna can be estimated by its dimensions and is generally resistive. Characteristic impedance of a Beverage antenna over perfect ground is given by [Ref 7: pp 19-21]:

$$Z_0 = 138 \log(4 \frac{h}{d}) \quad (\Omega) \quad (4.18)$$

In (4.18), (d) is the diameter of the wire in the same units as (h). Caution must be exercised when using this value of characteristic impedance since any sharp transition in the wire (i.e., vertical downleads) or real ground effects can reduce the accuracy of the calculation. Typical values for a Beverage antenna's characteristic impedance are 200-300 ohms.

If the impedance ( $Z_1$ ) of the terminating load of a Beverage antenna is known or can be estimated, reflection efficiency ( $\epsilon_r$ ) can be determined from the voltage reflection coefficient ( $\Gamma$ ) as follows:

$$\Gamma = \frac{Z_1 - Z_0}{Z_1 + Z_0} \quad (dimensionless) \quad (4.19)$$

$$\epsilon_r = 1 - |\Gamma|^2 \quad (dimensionless) \quad (4.20)$$

Other than reflection efficiency, accurate estimates of

other Beverage antenna losses cannot be determined by geometry alone. Nevertheless, there are other sources of lost power. Since a Beverage antenna is a relatively long antenna with a matched termination, relatively little power is reflected by the load. Instead, most of the power supplied by the transmitter that is not radiated is absorbed by the load or lost as heat to the ground.

Gain (G) is the product of antenna's directivity and efficiencies. The Mathcad Beverage antenna applications express gain as [Ref 3: p.43]:

$$G = \epsilon_r D_0 \quad (\text{dimensionless}) \quad (4.21)$$

Effective isotropic radiated power for the Beverage antenna (EIRP) is the product of the power radiated by the antenna and the directivity. (EIRP) is computed by [Ref 5: p. 62]:

$$EIRP = P_{rad} D_0 \quad (W) \quad (4.22)$$

Electromagnetic waves incident upon a Beverage antenna are normally assumed to be vertically polarized. If the incoming wave is not vertically polarized, a polarization mismatch occurs with the antenna and losses result. Polarization losses are determined from a polarization loss factor (PLF) given as:

$$PLF = |\vec{\sigma}_w \cdot \vec{\sigma}_a^*|^2 \quad (\text{dimensionless}) \quad (4.23)$$

In (4.23),  $(\sigma_a)$  and  $(\sigma_w)$  are the unit polarization vectors of the antenna and wave, respectively.

Maximum effective aperture ( $A_{em}$ ) is estimated from

directivity, (PLF), and reflection efficiency as follows [Ref 3: pp. 51-63]:

$$A_{em} = [PLF] \left[ \epsilon_r \left( \frac{\lambda^2}{4\pi} \right) D_0 \right] \quad (m^2) \quad (4.24)$$

The maximum effective height ( $h_{em}$ ) of a Beverage antenna can be determined using the results of (4.24) as follows [Ref 5: p. 42]:

$$h_{em} = 2 \sqrt{\frac{R_r A_{em}}{\eta_0}} \quad (m) \quad (4.25)$$

In (4.25), ( $R_r$ ) is radiation resistance and is written as:

$$R_r = \frac{2P_{rad}}{|I_0|^2} \quad (\Omega) \quad (4.26)$$

The conductor diameter must be much less than the length of the Beverage antenna to avoid unwanted radiation from vertical sections. For the purpose of Beverage antenna Mathcad applications, the following is assumed for proper antenna operations:

$$d \ll L \quad \text{if} \quad d \leq .01L \quad (m) \quad (4.27)$$

Table 4.2 and Figure 4.4 compare measured data to that calculated by the Mathcad applications for a Beverage antenna ( $L=110.4$  meters and  $h=1.23$  meters) operating over dry soil ( $\sigma=.003$  S/m and  $\epsilon_r=12$ ) at 18 MHz. Table 4.3 compares measured and calculated data for a Beverage antenna with  $L=110.4$  meters and  $h=1.13$  meters operating over wet soil ( $\sigma=.01$  S/m and  $\epsilon_r=17$ )

at 5 MHz [Ref 9: pp. 22-26].

**TABLE 4.2** Beverage Antenna Data Comparison

ANTENNA PARAMETER	MEASURED DATA	CALCULATED DATA
$\theta_{\max}$	18.5°	19.2°

**TABLE 4.3** Beverage Antenna Data Comparison

ANTENNA PARAMETER	MEASURED DATA	CALCULATED DATA
$Z_0$	450 $\Omega$	408 $\Omega$
$p$	.93	.91



### Comparison of Beverage Antenna Electric Fields

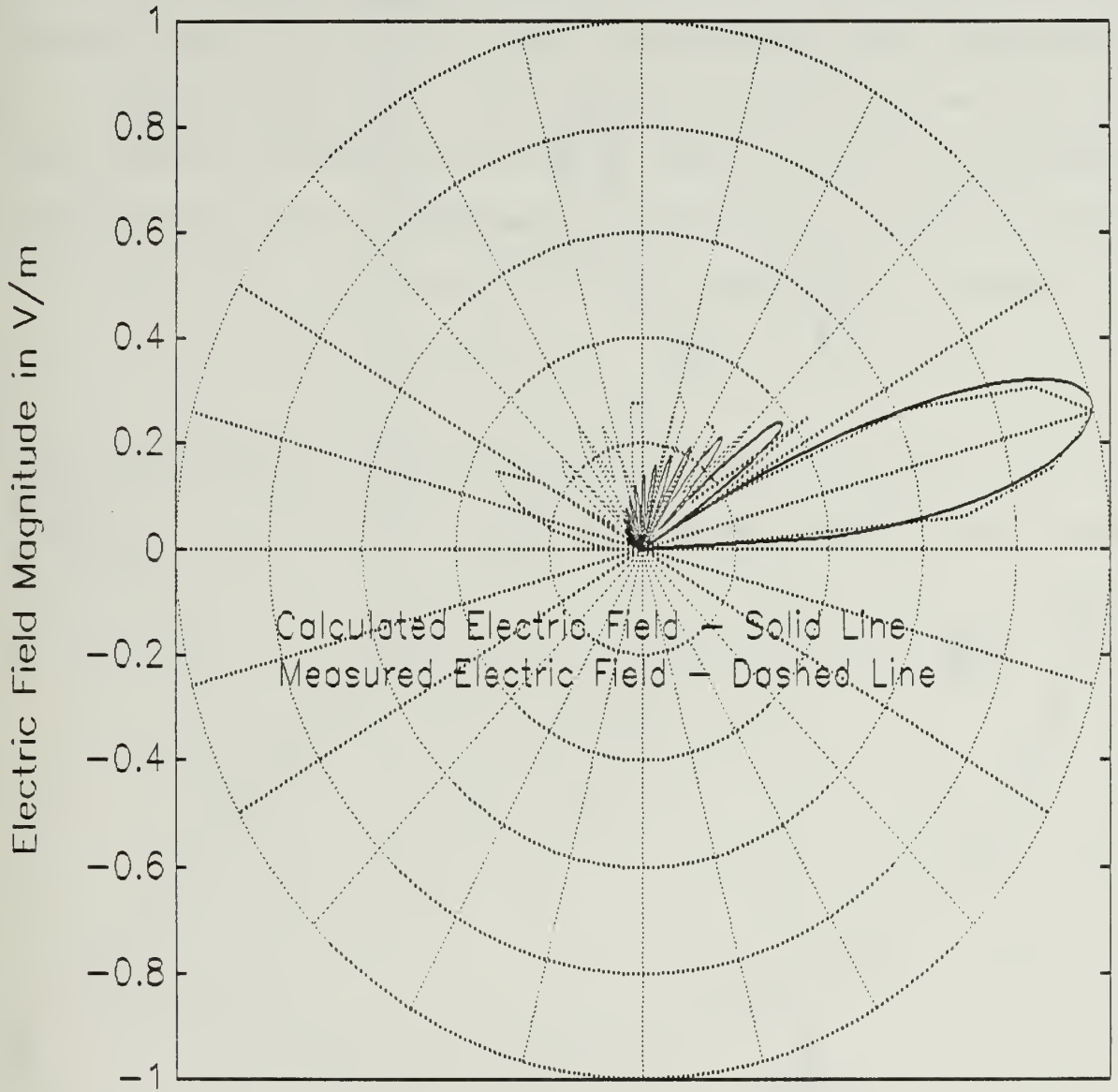

**FIGURE 4.4** Beverage Antenna Electric Field Patterns

## V. THE LOOP ANTENNA

A loop antenna is a coil of one or more turns. It is commonly used as a receiving antenna for operations in the lower frequency regions. The loop antenna is also used for direction finding and UHF transmissions [Ref 10: p. 6-1]. Loop antennas may have an air core or ferrite core. They may also be electrically large or small. For the purpose of the Mathcad applications, a loop antenna is considered electrically small if its radius (a) satisfies the following [Ref 3: p. 181]:

$$a \leq \frac{\lambda}{6\pi} \quad (m) \quad (5.1)$$

In (5.1), ( $\lambda$ ) is wavelength. The geometry of both large and small loop antennas is illustrated in Figure 5.1.

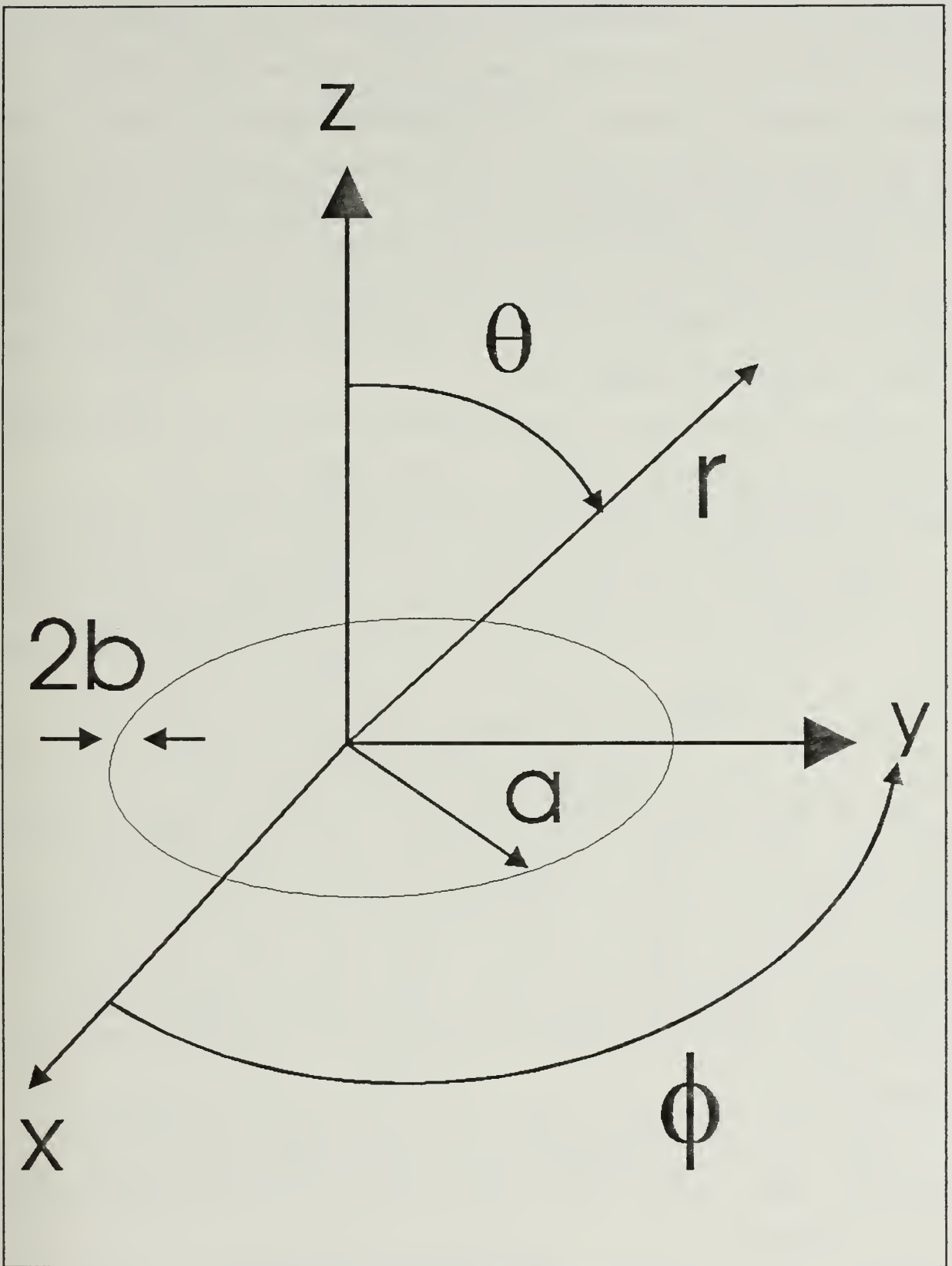

FIGURE 5.1 Loop Antenna Geometry

The radius of the conductor is  $(b)$  in Figure 5.1. For all loop antenna Mathcad applications the center of the loop is the origin and the antenna's axis is aligned parallel to the  $+z$  axis. When Mathcad applications examine the performance of a loop over a ground plane, the coordinate system is rotated with the antenna as necessary to obtain the desired geometry (i.e., the axis of a vertical loop is parallel to the ground and the  $+z$  axis).

#### A. THE ELECTRICALLY SMALL LOOP

Electrically small loops are normally used for low frequency reception or direction finding. Small loops are poor transmitters due to small radiation resistance ( $R_r$ ) and low conduction-dielectric efficiency ( $\epsilon_{cd}$ ). Transmitter performance can be improved with increased perimeter, adding additional turns, or insertion of a ferrite core [Ref 3: p. 164].

Two key assumptions are made in the analysis of a small loop. First, it is assumed that current around the loop is constant. This supposition allows the loop to be approximated by an infinitesimal magnetic dipole centered at the origin and parallel to the  $+z$  axis. Second, it is presumed that the various resistances and reactances of the loop can be computed from dimensional information and knowledge of the antenna's material properties.

Given the above assumptions in free space, the electric field ( $E$ ) for a small loop in the far-field is determined by [Ref 3: pp. 168-169]:

In (5.3),  $(S)$  is the cross-sectional area of the loop,  $(f)$  is the

$$E_r = E_\theta = 0 \quad (V/m) \quad (5.2)$$

$$E_\phi = \frac{k S f \mu_o I_o \sin(\theta) e^{-jk r}}{2 r} \quad (V/m) \quad (5.3)$$

frequency of interest, (r) is the distance from the origin to the observation point in the far-field, (I<sub>o</sub>) is the antenna feed current, (μ<sub>o</sub>) is the permeability of free space, and (k) is the free space wavenumber given by:

$$k = \frac{2\pi}{\lambda} \quad (m^{-1}) \quad (5.4)$$

As is the case in all Mathcad applications, current in the loop is normalized to one amp. Since electric field is not a function of (φ), the field pattern is symmetric when rotated about the antenna's axis.

It should be noted that (5.2) and (5.3) apply to all small loops, regardless of shape. Thus, (5.2) and (5.3) can be used for small square loops. However, it should also be noted that loop antenna Mathcad applications assume a circular loop is being analyzed and calculate cross-sectional area based on the radius provided by the user. In order to use the applications with rectangular loops or loops of an odd shape, the user must compute an equivalent radius (a) that will yield the correct area.

An observation point for any loop antenna is assumed to be in the far-field if the following conditions are valid [Ref 3: p.92]:

$$r \geq 1.6\lambda \quad (m) \quad (5.5)$$

$$r \geq 5D \quad (m) \quad (5.6)$$

$$r \geq \frac{2D^2}{\lambda} \quad (m) \quad (5.7)$$

In (5.5)-(5.7), (D) is the largest dimension of the loop. The largest dimension of the loop is assumed to be the diameter.

For small loops in free space, radiated power ( $P_{rad}$ ) is estimated as follows:

$$P_{rad} = \eta_0 \left( \frac{\pi}{12} \right) (ka)^4 |I_0|^2 \quad (W) \quad (5.8)$$

In (5.8), ( $\eta_0$ ) is the intrinsic impedance of free space.

The directivity ( $D_0$ ) of a small loop in free space is 1.5 and, ignoring polarization any mismatches, the maximum effective aperture ( $A_{em}$ ) of a lossless loop is written as [Ref 3: p. 175]:

$$A_{em} = \frac{3\lambda^2}{8\pi} \quad (m^2) \quad (5.9)$$

The ohmic resistance of any loop antenna ( $R_{ohmic}$ ), including multiple turn antennas, is estimated by the following [Ref 3: pp.171-172]:

$$R_{ohmic} = N \frac{a}{b} R_s \left( \frac{R_p}{R_o} + 1 \right) \quad (\Omega) \quad (5.10)$$

In (5.10), (N) is the number of turns, ( $R_s$ ) is the surface impedance of the conductor, ( $R_p$ ) is the ohmic resistance due to proximity effect, and ( $R_o$ ) is the ohmic skin effect resistance per unit length. If the conductivity ( $\sigma_c$ ) of the conductor is known, the surface impedance of the conductor is computed by:

$$R_s = \sqrt{\frac{\pi f \mu_o}{\sigma_c}} \quad (\Omega) \quad (5.11)$$

Given the spacing between turns ( $q$ ) has been measured, the ratio of ( $R_p$ ) to ( $R_o$ ) is estimated using Figure 5.2 [Ref 3: p. 172].

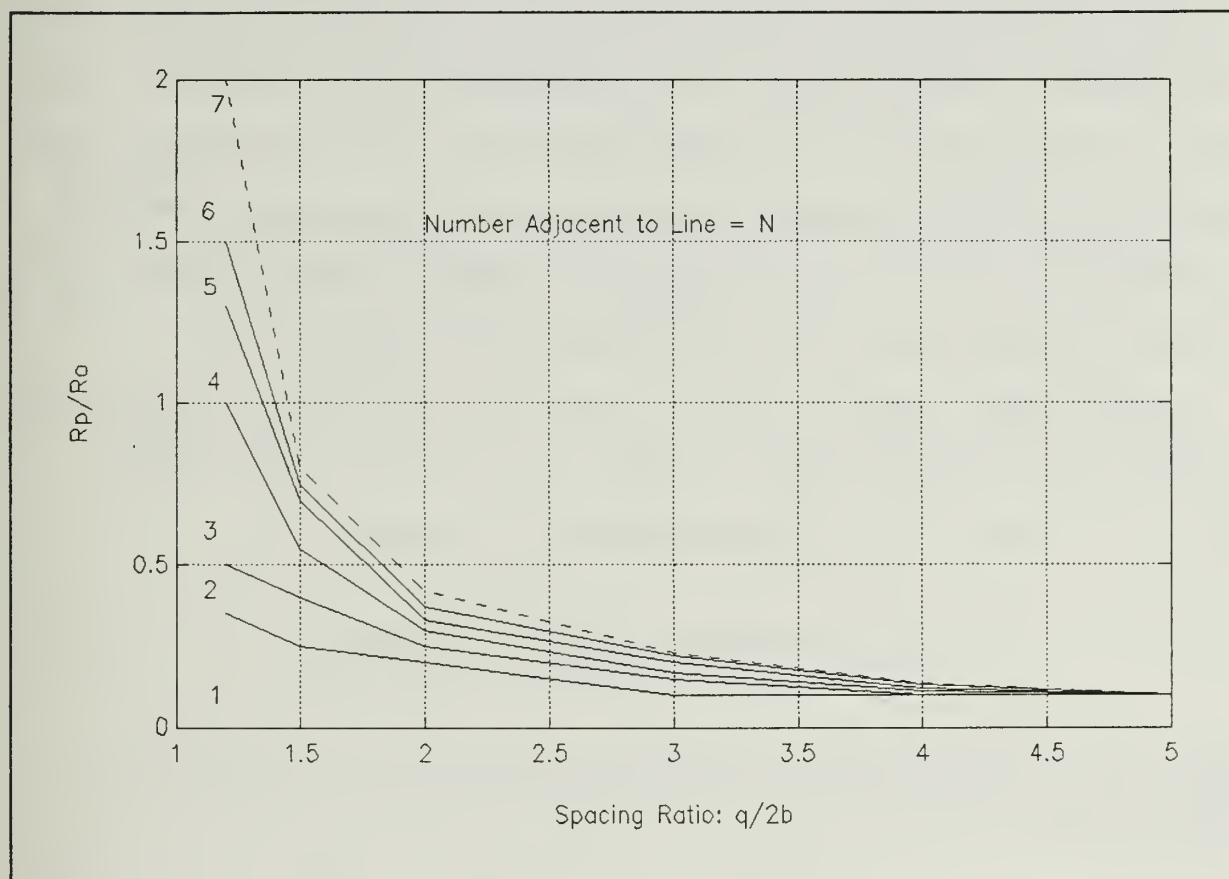

FIGURE 5.2  $R_p/R_o$

The radiation resistance of a small loop in free space is determined using the circumference of the loop ( $C$ ) as follows [Ref 3: pp. 170-171]:

$$R_r = 20\pi^2 \left(\frac{C}{\lambda}\right)^4 N^2 \quad (\Omega) \quad (5.12)$$

When the radiation and ohmic resistance of any antenna



has been calculated, the conduction-dielectric efficiency of the antenna is determined by:

$$\epsilon_{cd} = \frac{R_r}{R_{ohmic} + R_r} \quad (\text{dimensionless}) \quad (5.13)$$

From (5.10) and (5.12) it can be seen that ohmic resistance is **directly** proportional to the number of turns while radiation resistance is proportional to the **square** of the number of turns. Thus, as shown in (5.13) conduction-dielectric efficiency can be improved by increasing the number of turns in a loop antenna. It can also be seen in (5.10) and (5.12) that increasing the radius of the loop improves conduction-dielectric efficiency.

Additional improvements to conduction-dielectric efficiency may be made by inserting a ferrite core in the loop antenna. If a core is added, (5.12) is modified as follows:

$$R_r = 20\pi^2 \left(\frac{C}{\lambda}\right)^4 \left(\frac{\mu_e}{\mu_o}\right)^2 N^2 \quad (\Omega) \quad (5.14)$$

Effective permeability of the ferrite core ( $\mu_e$ ) in (5.14) is computed by:

$$\mu_e = \frac{\mu_f}{1 + D_{demag}(\mu_f - 1)} \quad (H/m) \quad (5.15)$$

In (5.15), ( $\mu_f$ ) is the actual permeability of the core material and ( $D_{demag}$ ) is an experimentally derived demagnetization factor. Demagnetization factor as a function of the ratio of core length to diameter is shown in Figure 5.3 [Ref 3: pp. 196-197].

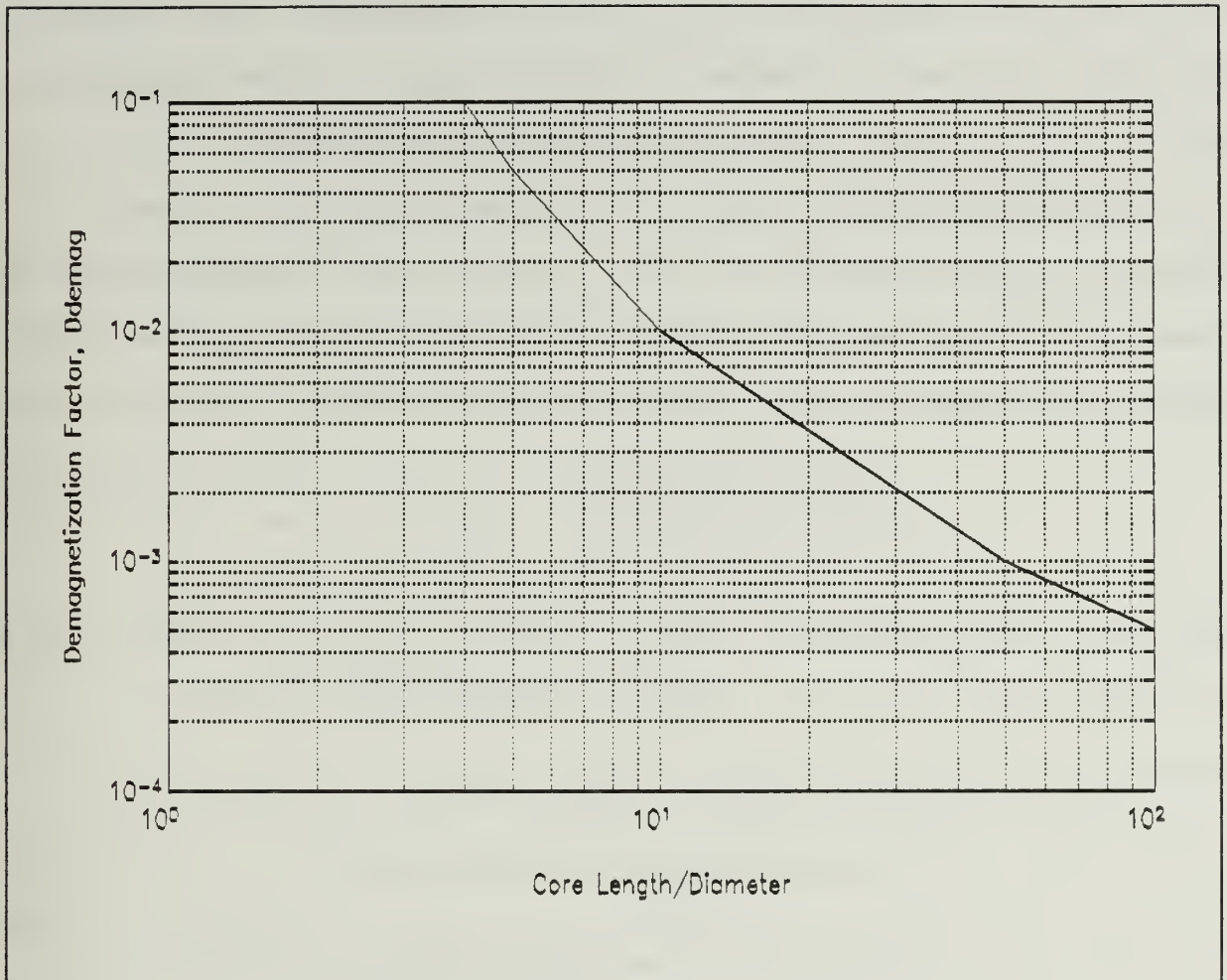

FIGURE 5.3 Demagnetization Factor

Any antenna parameter that requires use of permeability in its formula must be approximated in the Mathcad applications by replacing  $(\mu_o)$  with  $(\mu_e)$  [Ref 11: pp. 86-89].

When, a loop antenna is actually employed, it is not in free space and real ground must be considered. Although real ground does not change the components of electric field given by (5.2), it does modify  $(E_\phi)$  in (5.3). Since the orientation of the loop with respect to ground determines the polarization of the loop's electromagnetic wave, alignment of the antenna must be known

before electric field can be correctly computed. In order to keep the loop antenna Mathcad applications moderately simple, only horizontal and vertical loops are considered.

Although modeled by an infinitesimal vertical magnetic dipole, a small horizontal loop (i.e., +z axis perpendicular to ground) has horizontally polarized electromagnetic waves. The horizontal reflection coefficient ( $\Gamma_h$ ) is [Ref 5: pp. 229-230]:

$$\Gamma_H = \frac{\cos(\theta) - \sqrt{\epsilon_r' - \sin^2(\theta)}}{\cos(\theta) + \sqrt{\epsilon_r' - \sin^2(\theta)}} \quad (\text{dimensionless}) \quad (5.16)$$

In (5.16), the relative complex permittivity ( $\epsilon_r'$ ) of the ground is calculated using the relative permittivity ( $\epsilon_r$ ) and conductivity ( $\sigma$ ) of the ground by:

$$\epsilon_r' = \epsilon_r - j \frac{\sigma}{2\pi f \epsilon_0} \quad (\text{dimensionless}) \quad (5.17)$$

In (5.17), ( $\epsilon_0$ ) is the relative permittivity of free space.

The total electric field of a small horizontal loop over ground is the sum of the direct path signal and ground reflected signal. One can use image theory to estimate the contribution to the far-field pattern by ground reflections. The total electric field expression for a small horizontal loop positioned a distance (h) above the ground is:

$$E_{\phi_{hor}} = \frac{kSf\mu_0 I_0 \sin(\theta)}{2r} e^{-jk r} [1 - \Gamma_h e^{-j2kh \cos(\theta)}] \quad (V/m) \quad (5.18)$$

Note in (5.18) that the image antenna is a vertical infinitesimal magnetic dipole. Thus, the contribution of the image is

subtracted from the contribution of the actual antenna. The Mathcad loop antenna applications ignore the minor contribution of the surface wave to the electric field.

The total electric field of a vertical loop over real ground can be determined in a manner similar to (5.18), but the vertical reflection coefficient ( $\Gamma_v$ ) must be used for the image antenna's contribution to the far-field pattern. The equation for vertical reflection coefficient is [Ref 5: pp. 231-232]:

$$\Gamma_v = \frac{\epsilon_r \cos\left(\frac{\pi}{2} - \theta\right) - \sqrt{\epsilon_r - \sin^2\left(\frac{\pi}{2} - \theta\right)}}{\epsilon_r \cos\left(\frac{\pi}{2} - \theta\right) + \sqrt{\epsilon_r - \sin^2\left(\frac{\pi}{2} - \theta\right)}} \quad (\text{dimensionless}) \quad (5.19)$$

For a vertically mounted small loop, the image antenna's contribution is added to that of the actual antenna. Thus, total electric field for a small vertical loop is written as:

$$E_{\phi_{\text{vert}}} = \frac{kSf\mu_o I_o \sin(\theta)}{2r} e^{-jkr} [1 + \Gamma_v e^{-j2kh\cos(\theta)}] \quad (\text{V/m}) \quad (5.20)$$

It should be noted by application users that (5.20) applies to loops located in a coordinate system that has been rotated with the axis of the loop such that the +z axis is parallel to the loop axis and the ground.

If the electric field of a small loop antenna over real ground is known, several parameters can be computed using general antenna formulas. Far-field equations for radiation intensity (U), radiated power, directivity, and radiation resistance are as follows:

$$U = \frac{r^2}{2\eta_0} |E|^2 \quad (W/solid\ ang) \quad (5.21)$$

$$P_{rad} = \iint_{\Omega} U \sin(\theta) d\theta d\phi \quad (W) \quad (5.22)$$

$$D_o = 4\pi \frac{U_{max}}{P_{rad}} \quad (dimensionless) \quad (5.23)$$

$$R_r = \frac{2P_{rad}N^2}{|I_o|^2} \quad (\Omega) \quad (5.24)$$

In (5.22),  $(\Omega)$  is a half sphere that encloses a loop over ground in the far-field. In (5.23),  $(U_{max})$  is the maximum radiation intensity anywhere on the half sphere as determined by applying (5.22).

A unique feature of small loop antennas is that most efficiency terms associated with it can be calculated from the loop's measurements. One of the reasons for this attribute is the fact that input reactance  $(X_i)$  can be reasonably estimated from [Ref 5: pp. 102-103]:

$$X_i = 2\pi f a \mu_0 [\ln(8 \frac{a}{b}) - 1.75] \quad (\Omega) \quad (5.25)$$

Input impedance  $(Z_i)$  for the small loop is found using the formula:

$$Z_i = R_i + jX_i \quad (\Omega) \quad (5.26)$$

In (5.26), input resistance  $(R_i)$  is the sum of radiation and ohmic resistance and is written as:

$$R_i = R_r + R_{ohmic} \quad (\Omega) \quad (5.27)$$

If the characteristic impedance of the antenna's feed line is known or can be presumed, the voltage reflection coefficient ( $\Gamma$ ) and reflection efficiency ( $\epsilon_r$ ) are determined by:

$$\Gamma = \frac{Z_i - Z_0}{Z_i + Z_0} \quad (\text{dimensionless}) \quad (5.28)$$

$$\epsilon_r = 1 - |\Gamma|^2 \quad (\text{dimensionless}) \quad (5.29)$$

As previously discussed, the polarization of a small loop matches the orientation of the loop (i.e., a horizontal loop is horizontally polarized). Thus, if the polarization of an incoming wave is known or can be estimated, one can use the dot product of the unit polarization vector of a small loop antenna ( $\sigma_a$ ) and the unit polarization vector of an incoming wave ( $\sigma_w$ ) to compute the polarization loss factor (PLF) as follows [Ref 3: p. 51]:

$$PLF = |\vec{\sigma}_w \cdot \vec{\sigma}_a|^2 \quad (\text{dimensionless}) \quad (5.30)$$

With the efficiency and loss terms of the small loop estimated by (5.13), (5.29), and (5.30); gain (G), maximum effective aperture ( $A_{em}$ ), and effective isotropic radiated power (EIRP) can be expressed as [Ref 3 pp. 43-63]:



$$G = \epsilon_r \epsilon_{cd} D_o \quad (\text{dimensionless}) \quad (5.31)$$

$$A_{em} = \epsilon_r \epsilon_{cd} D_o (PLF) \left( \frac{\lambda^2}{4\pi} \right) \quad (m^2) \quad (5.32)$$

$$EIRP = P_{rad} D_o \quad (W) \quad (5.33)$$

Maximum effective height ( $h_{em}$ ) can be determined from the maximum effective aperture and radiation resistance of the antenna as follows [Ref 2: p. 42]:

$$h_{em} = 2 \sqrt{\frac{R_r A_{em}}{\eta_o}} \quad (m) \quad (5.34)$$

Mathcad applications are developed assuming bandwidth (BW) of an antenna is the range of frequencies over which all computations will be valid. For the small loop antenna Mathcad applications to be valid, (5.1) must hold. Thus, the radius of the loop will define lowest operating frequency ( $f_{min}$ ), the highest operating frequency ( $f_{max}$ ), and the bandwidth of the antenna as shown below:

$$f_{min} \geq 0 \quad (HZ) \quad (5.35)$$

$$f_{max} \leq \frac{c}{6\pi a} \quad (HZ) \quad (5.36)$$

$$BW = f_{max} - f_{min} \quad (HZ) \quad (5.37)$$

The electric field patterns and antenna parameters obtained using the small loop Mathcad applications for a small loop in free space are identical to published results obtained using



method of moments techniques [Ref 3: pp. 169-180]. A comparison of the results of the Mathcad applications with measured data for a small loop (a=.25 meters, b=.005 meters) located 2.5 meters above a reflecting plane ( $\sigma=6 \times 10^7$  S/m,  $\epsilon_r=1$ ) receiving a 30 MHz signal is provided in Table 5.1 [Ref 6: p. 5-14].

**TABLE 5.1** Small Loop Antenna Data Comparison

ANTENNA PARAMETER	MEASURED DATA	CALCULATED DATA
DIRECTIVITY	7.0 dB	6.5 dB

**B. THE ELECTRICALLY LARGE LOOP**

Electrically large loops are those loops that do not satisfy (5.1). Use of these antennas is somewhat rare, with radii exceeding one wavelength normally not practical. Large loops are, in general, significantly more difficult to analyze than small loops since large loops cannot be approximated by infinitesimal magnetic dipoles. In addition, the input reactance of a large loop antenna cannot be calculated from the loop's geometry.

The polarization of a large horizontal loop over real ground is horizontal, but the polarization of a large vertical loop is not vertical. Due to the complexities of computing the polarization and ground reflection coefficients of a large

vertical loop, the Mathcad large loop antenna applications will only examine the free space and horizontal cases.

To begin analysis of the far-field radiation pattern of a large loop in free space, one must assume that the current on the loop is constant. As illustrated in Figure 5.4, this is an approximation that deteriorates with the size of the loop [Ref 3: p. 184].

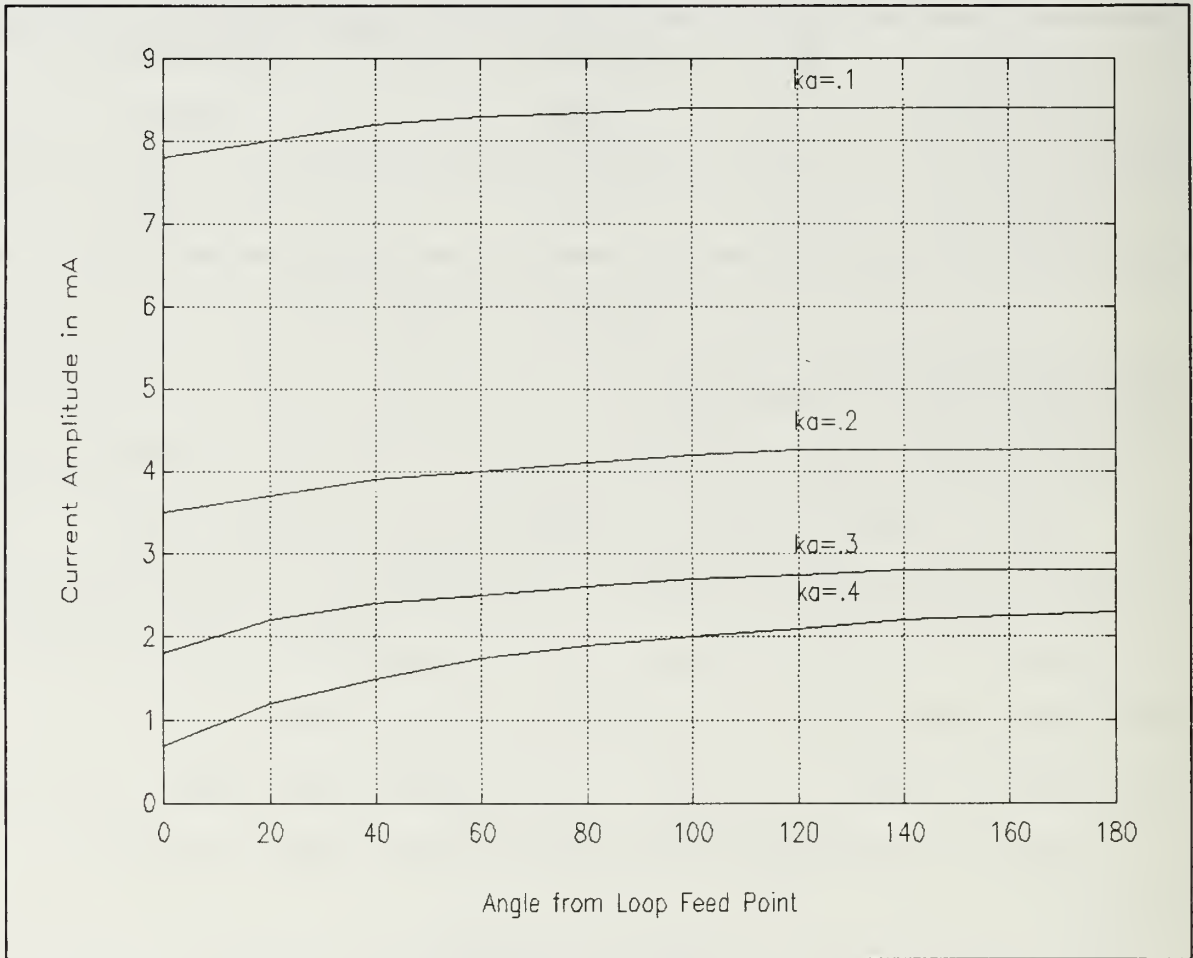

FIGURE 5.4 Current Magnitude Distribution for a Large Loop

If one assumes that loop current is constant, (5.2) applies to large loop antennas. The other component of electric field

$(E_\phi)$  is approximated by [Ref 3: pp. 176-178]:

$$E_\phi \approx \frac{2\pi fa\mu_o I_o e^{-jkr}}{2r} J_1(kasin(\theta)) \quad (5.38)$$

In (5.38),  $J_1(kasin(\theta))$  is a Bessel function of the first kind of order one. With the horizontal reflection coefficient of the ground computed per (5.16), total electric field of the large horizontal loop over real ground is given by:

$$E_{hor} = \frac{2\pi fa\mu_o I_o}{2r} e^{-jkr} J_1(kasin(\theta)) * [1 - \Gamma_h e^{-j2krcos(\theta)}] \quad (V/m) \quad (5.39)$$

Radiated power for a large loop in free space is computed using (5.22), where radiation intensity is given by (5.21) and electric field is computed by (5.38). It should be noted that the far-field conditions of (5.5)-(5.7) must be satisfied if the Mathcad large loop antenna electric field and radiated power calculations are to be valid.

Large loop, free space approximations for radiation resistance, directivity, maximum effective aperture, and maximum radiation intensity are as follows [Ref 3: p. 181] [Ref 11: pp. 78-79]:

$$R_r = 60\pi^2 \left(\frac{C}{\lambda}\right)^2 N^2 \quad (\Omega) \quad (5.40)$$

$$D_o = .682 \left(\frac{C}{\lambda}\right) \quad (\text{dimensionless}) \quad (5.41)$$

$$A_{em} = .0543 (\lambda C) \quad (m^2) \quad (5.42)$$

$$U_{\max} = \frac{(2\pi f a \mu_o)^2 |I_o|^2}{8\eta_o} (.584)^2 \quad (W/\text{solid ang}) \quad (5.43)$$

For the horizontal loop over real ground, radiation intensity is given by (5.21), where the electric field is computed in (5.39). With radiation intensity known, radiated power is calculated by (5.22) and effective isotropic radiated power is computed using (5.33). Radiation resistance and directivity for the horizontal loop are determined using generic antenna formulas as follows:

$$R_r = \frac{2P_{rad}N^2}{|I_o|^2} \quad (\Omega) \quad (5.44)$$

$$D_o = \frac{4\pi U_{\max}}{P_{rad}} \quad (\text{dimensionless}) \quad (5.45)$$

Ohmic resistance for the large loop antenna is given by (5.8). With radiation resistance given by (5.40) or (5.44), as applicable, the conduction-dielectric efficiency of the antenna is computed using (5.13).

Without knowledge of the input reactance, it is impossible to compute reflection efficiency of a large loop antenna.

Therefore, Mathcad applications for large loops assume a factor of unity for reflection efficiency and calculate gain as follows:

$$G = \epsilon_{cd} D_o \quad (\text{dimensionless}) \quad (5.46)$$

In general, the polarization loss factor given in (5.30) cannot be determined for an arbitrary large loop. Thus, (PLF) for large loops is assumed to be unity and maximum effective aperture is given by:

$$A_{em} = \epsilon_{cd} D_o \left( \frac{\lambda^2}{4\pi} \right) \quad (m^2) \quad (5.47)$$

With maximum effective aperture determined for a large loop using (5.47), maximum effective height is found by applying (5.34).

The bandwidth of a large loop is determined by the loop's radius as follows:

$$\frac{\lambda}{6\pi} \leq a \leq \lambda \quad (m) \quad (5.48)$$

$$\frac{c}{6a\pi} \leq f \leq \frac{c}{a} \quad (Hz) \quad (5.49)$$

$$BW = \frac{c}{a} \left( 1 - \frac{1}{6\pi} \right) \quad (Hz) \quad (5.50)$$

Figure 5.5 compares the electric field pattern obtained from the Mathcad applications for a large loop (a=.46 meters, b=.05 meters) in free space receiving a 330 MHz signal with published results obtained from method of moments techniques [Ref 3: p. 180]. Table 5.2 compares antenna parameters calculated using the Mathcad applications with measured results for a large loop

(a=.46 meters, b=.05 meters) located .72 meters above a reflecting ground plane ( $\sigma=6 \times 10^7$  S/m,  $\epsilon_r=1$ ) receiving a 104 MHz signal [Ref 6: p. 5-14].

**TABLE 5.2** Large Loop Antenna Data Comparison

ANTENNA PARAMETER	MEASURED DATA	CALCULATED DATA
INPUT RESISTANCE	150 $\Omega$	207 $\Omega$
DIRECTIVITY	7.0 dB	6.7 dB



### Comparison of Large Loop Electric Fields

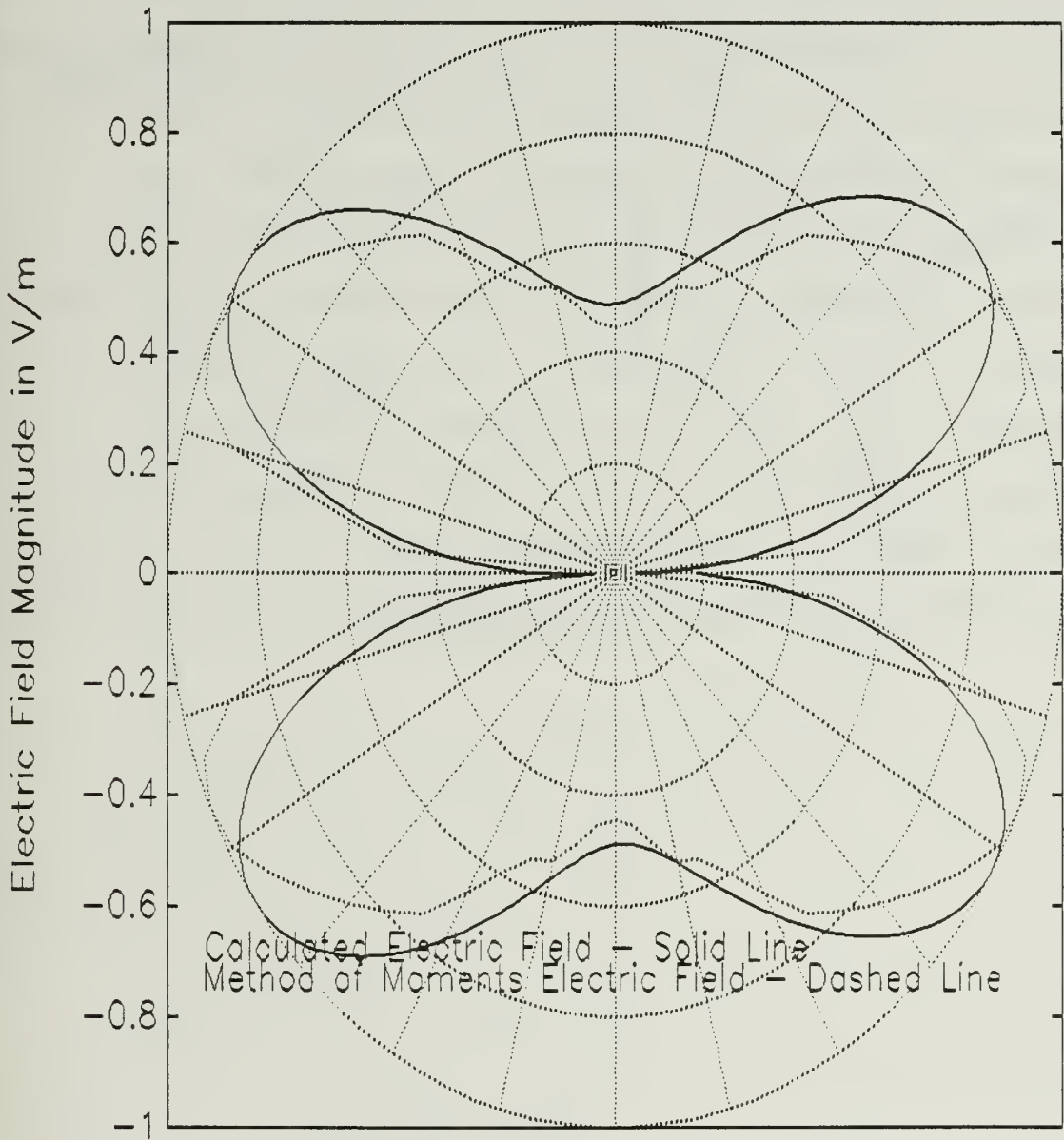

FIGURE 5.5 Large Loop Antenna Electric Field Patterns



## VI. THE BEDSPRING ANTENNA

The vertical directivity ( $D_0$ ) of a horizontal dipole over real ground may be improved by placing identical elements in a straight line above the original. A vertical line of horizontal dipoles is commonly referred to as a bay. In a similar manner, one may place additional bays adjacent to the original and achieve an improvement in horizontal directivity. Further improvements to the gain ( $G$ ) of this array of bays may be realized by placing a reflector on one side to simulate the existence of a conducting plane. The entire arrangement of bays and reflector is referred to as either a bedspring or a curtain antenna. A bedspring array is frequently used for high frequency (3-30 MHz) short wave radio systems [Ref 10: pp. 21-1 - 21-6]. A typical bedspring antenna arrangement is illustrated in Figure 6.1.

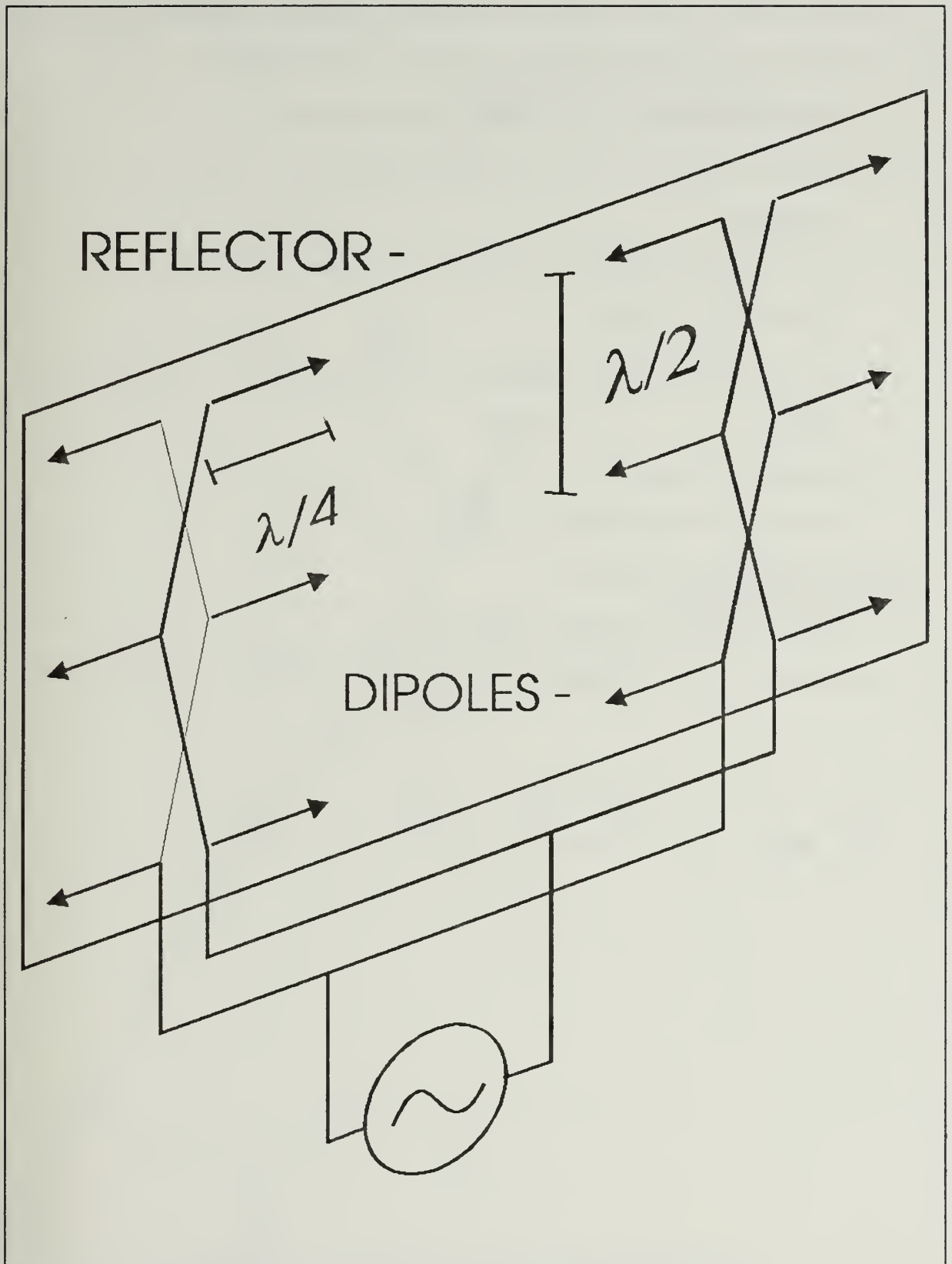

FIGURE 6.1 A Typical Bedspring Antenna

To implement the Mathcad software for the bedspring antenna applications, the following dimensions are needed:

$Z_i$  = height of the  $i^{\text{th}}$  element above ground

$Z_i - Z_{i-1}$  = vertical spacing between the  $i^{\text{th}}$  and the  $(i-1)^{\text{th}}$  element

$Y_i$  = horizontal position (dipole center) of the  $i^{\text{th}}$  bay ( $Y_0 = 0$ )

$Y_i - Y_{i-1}$  = horizontal spacing between the  $i^{\text{th}}$  and the  $(i-1)^{\text{th}}$  bay

$N$  = number of bays

$M$  = number of elements in each bay

$X_1$  = reflector position

$l$  = half-length of each element

The geometry for the bedspring antenna is shown in Figure 6.2.

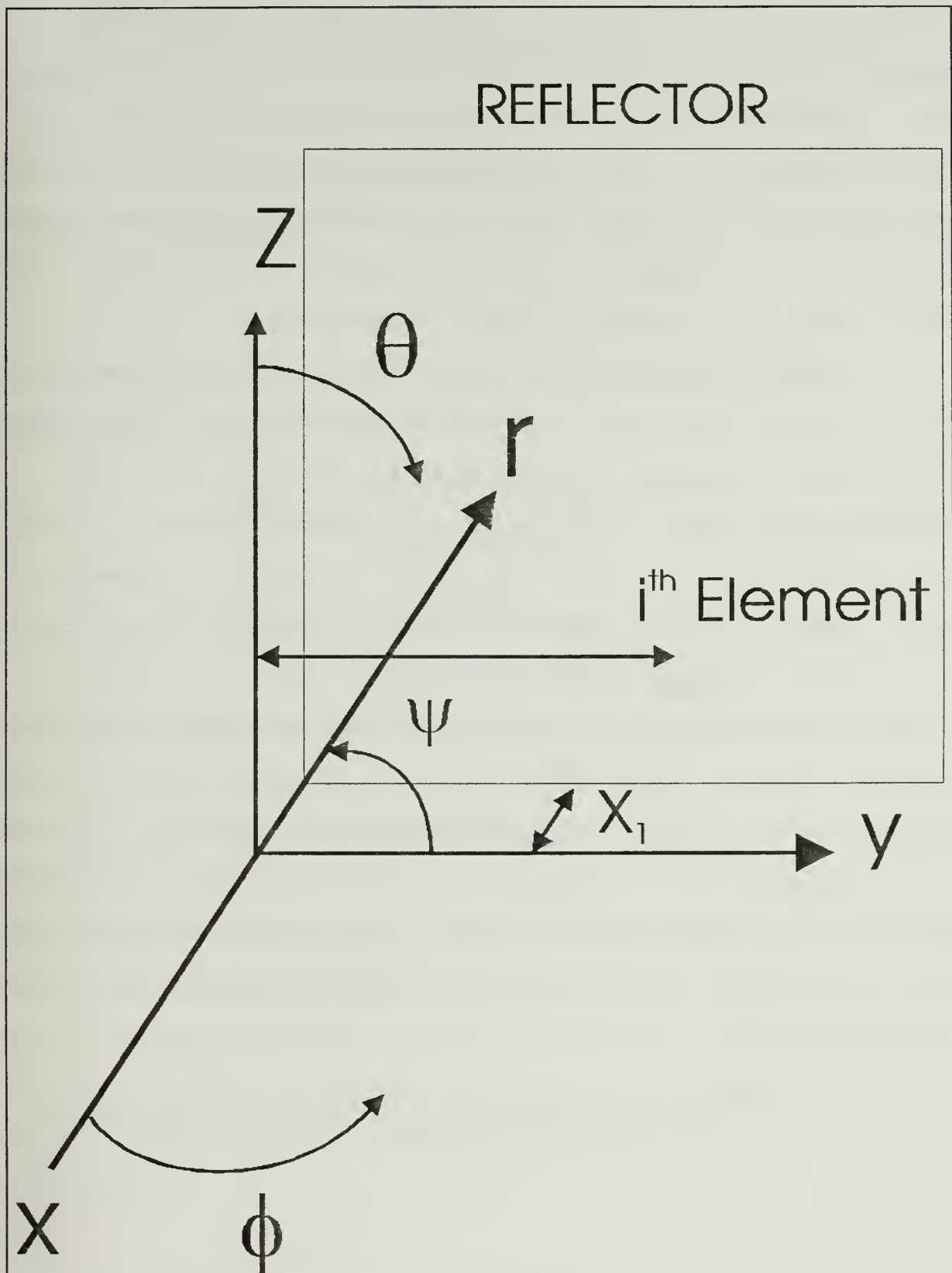

FIGURE 6.2 Bedspring Antenna Geometry

In Figure 6.2 ,  $(\psi)$  is the angle between the +y axis and the vector  $(r)$  from the origin to the observation point in the far-field. Bedspring antenna Mathcad applications assume that all antenna elements are identical horizontal dipoles parallel to each other and the y axis. The applications also presume that the reflector is a perfect vertical conducting plane, parallel to the y-z plane, and located in the -x half-space.

The assumption that the reflector is a perfect conducting plane is fairly reasonable, as experimental data has shown that the reflector typically improves gain by 2.5 to 3.0 dB. The reflector screen may be constructed from tuned elements, such as half-wave dipoles, or it may consist of a pattern of closely spaced, parallel wires. The reflector is normally located about one-quarter wavelength behind the antenna [Ref 10: p. 21-6].

The electric field (E) pattern for the bedspring antenna is computed using the principle of pattern multiplication for antenna arrays. Using the identity  $\cos(\psi)=\sin(\theta)\cos(\phi)$ , one may predict the electric field components of a single bay. If all elements in the bay are excited by a sinusoidal current with maximum amplitude  $(I_m)$ , the electric field components are [Ref 12: pp. 229-231]:

$$E_{\theta 1} = -j60I_m \frac{e^{-jkr}}{r} \frac{[\cos(kl \sin(\theta) \sin(\phi)) - \cos(kl)]}{[1 - \sin^2(\theta) \sin^2(\phi)]} \sin(\phi) \cos(\theta) [A]$$

(V/m)

(6.1)

$$E_{\phi_1} = j60I_m \frac{e^{-jkz}}{r} \frac{[\cos(kl \sin(\theta) \sin(\phi)) - \cos(kl)]}{[1 - \sin^2(\theta) \sin^2(\phi)]} \cos(\phi) [B] \quad (6.2)$$

(V/m)

Given the wavelength ( $\lambda$ ) of the frequency of interest, the wavenumber ( $k$ ) in (6.1) and (6.2) is given by:

$$k = \frac{2\pi}{\lambda} \quad (m^{-1}) \quad (6.3)$$

The complex coefficients (A) and (B) in (6.1) and (6.2), respectively, are computed as follows:

$$A = \sum_{i=1}^M C_i e^{jkz_i (\cos(\theta) - \cos(\theta_o))} [1 - R_v e^{-j2kz_i \cos(\theta)}] \quad (6.4)$$

(dimensionless)

$$B = \sum_{i=1}^M C_i e^{jkz_i (\cos(\theta) - \cos(\theta_o))} [1 + R_h e^{-j2kz_i \cos(\theta)}] \quad (6.5)$$

(dimensionless)

The relative amplitude of excitation ( $C_i$ ) of the  $i^{\text{th}}$  dipole with respect to the first element in the first bay is required for both (6.4) and (6.5). Equations (6.4) and (6.5) also use ( $\theta_o$ ) to represent the desired vertical scan angle of the antenna. The vertical scan angle is approximately equal to the progressive phase shift from one element to the next in the bay. In (6.4), ( $R_v$ ) is the vertical reflection coefficient over real ground. In (6.5), ( $R_h$ ) is the horizontal reflection coefficient over real ground. These reflection coefficients are determined by [Ref 5: pp. 229-235]:

$$\Gamma_V = \frac{\epsilon_r \cos(\theta) - \sqrt{\epsilon_r' - \sin^2(\theta)}}{\epsilon_r \cos(\theta) + \sqrt{\epsilon_r' - \sin^2(\theta)}} \quad (\text{dimensionless}) \quad (6.6)$$

$$\Gamma_H = \frac{\cos(\theta) - \sqrt{\epsilon_r' - \sin^2(\theta)}}{\cos(\theta) + \sqrt{\epsilon_r' - \sin^2(\theta)}} \quad (\text{dimensionless}) \quad (6.7)$$

The relative complex permittivity ( $\epsilon_r$ ) of the ground needed to determine both reflection coefficients is calculated using the relative permittivity ( $\epsilon_r$ ) of the ground, the conductivity of the ground ( $\sigma$ ), and the permittivity of free space ( $\epsilon_0$ ) as follows:

$$\epsilon_r = \epsilon_r - j \frac{\sigma}{2\pi f \epsilon_0} \quad (\text{dimensionless}) \quad (6.8)$$

The electric field components of (6.1) and (6.2) apply only in the far-field. Thus, all of the following conditions must hold if the computed electric fields are to be valid [Ref 3: pp. 92-93]:

$$r > 1.6\lambda \quad (m) \quad (6.9)$$

$$r > 5D \quad (m) \quad (6.10)$$

$$r > \frac{2D^2}{\lambda} \quad (m) \quad (6.11)$$

In (6.10) and (6.11), (D) is the largest physical dimension in any direction of the antenna and is equal to the bedspring's diagonal length.

If one assumes that the amplitude and phase of the feed current in corresponding elements in each bay is the same, the array factor ( $S_y$ ) for N bays is written as [Ref 12: pp. 229-231]:



$$S_y = \sum_{n=1}^N e^{jky_{n-1} \sin(\theta) [\sin(\phi) - \sin(\phi_o)]} \quad (\text{dimensionless}) \quad (6.12)$$

In (6.12),  $(\phi_o)$  is the azimuthal scan angle of the antenna. The azimuthal scan angle is approximately equal to the progressive phase shift between bays in the bedspring antenna.

The array factor accounting for the perfect image from the reflector ( $S_x$ ) is:

$$S_x = 1 - e^{-j2kx_1 \sin(\theta) \cos(\phi)} \quad (\text{dimensionless}) \quad (6.13)$$

The total electric field components ( $E_{\theta t}$ ,  $E_{\phi t}$ ) are computed by taking the product of all appropriate array factors and the pattern for a single bay as follows:

$$E_{\theta t} = E_{\theta 1} S_y S_x \quad (\text{V/m}) \quad (6.14)$$

$$E_{\phi t} = E_{\phi 1} S_x S_y \quad (\text{V/m}) \quad (6.15)$$

The radiation intensity ( $U$ ) of the bedspring antenna is determined from ( $E_{\theta t}$ ) and ( $E_{\phi t}$ ) by [Ref 3: pp. 27-29]:

$$U = \frac{r^2}{2\eta_o} [ |E_{\theta t}|^2 + |E_{\phi t}|^2 ] \quad (\text{W/solid ang}) \quad (6.16)$$

In (6.16),  $(\eta_o)$  is the intrinsic impedance of free space.

Using the radiation intensity calculated in (6.16), one may calculate radiated power ( $P_{rad}$ ) by computing the following integral over the quarter sphere ( $\Omega$ ) through which electromagnetic energy from the antenna flows:

$$P_{rad} = \iint_{\Omega} U \sin(\theta) d\theta d\phi \quad (\text{W}) \quad (6.17)$$

Mathcad bedspring antenna applications assume that each element is excited by a feed current with the same maximum amplitude. Although this assumption may seem restrictive, it has been experimentally determined that maximum gain is obtained from a bedspring antenna if all radiator currents are of equal amplitude. Therefore, the following approximation for antenna feed current ( $I_o$ ) holds [Ref 10: p. 21-17]:

$$|I_o| = M \cdot N \cdot |I_m| \quad (\text{amps}) \quad (6.18)$$

It should be noted that the bedspring antenna applications normalize all element excitation currents to one amp.

Given the magnitude of the feed current for the entire antenna, radiation resistance ( $R_r$ ) for the complete assembly is determined as follows:

$$R_r = \frac{2P_{rad}}{|I_o|^2} \quad (\Omega) \quad (6.19)$$

Directivity is computed from radiation intensity and radiated power by:

$$D_o = \frac{4\pi U_{max}}{P_{rad}} \quad (\text{dimensionless}) \quad (6.20)$$

In (6.20), ( $U_{max}$ ) is the maximum value of radiation intensity anywhere on the quarter sphere encompassing the antenna's emissions.

Gain is the product of total antenna efficiency ( $\epsilon_t$ ) and directivity. Gain is normally expressed as:

$$G = \epsilon_c D_o \quad (\text{dimensionless}) \quad (6.21)$$

Unfortunately, the total efficiency of a bedspring antenna cannot be easily determined from its dimensions. For example, input impedance is a key parameter needed to calculate an antenna's reflection efficiency. However, input impedance has several components that are extremely difficult to determine. Self impedance of each element, mutual impedance between real elements in the array, mutual impedance between real elements and image elements from the reflector, and mutual impedance between real elements and imperfect images in the ground plane all contribute to input impedance. Because of the complexity of computations, input impedance of the bedspring antenna can only be estimated by an extensive method of moments algorithm.

Other problems computing antenna efficiency include the possible existence of tuning devices in the feed lines; probable lack of sinusoidal current distributions for elements of arbitrary length; and inability to properly model the ground, reflector screen, and characteristic impedance of the feed assembly. Nevertheless, bedspring antenna gain can be adequately estimated despite the extensive calculations associated with precise modeling. Experience has shown that a properly tuned bedspring antenna operating within the band of expected frequencies exhibits very little loss. Consequently, gain is estimated in Mathcad bedspring applications as [Ref 10: p. 21-3]:

$$G \approx 10 \log(D_o) - 2 \quad (dB) \quad (6.22)$$

Effective Isotropic Radiated Power (EIRP) is the product of radiated power and directivity and is computed by [Ref 5: p. 62]:

$$EIRP = P_{rad} D_o \quad (W) \quad (6.23)$$

The bedspring antenna's unit polarization vector ( $\sigma_a$ ) may be found by converting the electric field components of (6.14) and (6.15) to Cartesian coordinates as follows [Ref 4: pp. 35-36, 364-367]:

$$E_x = E_\theta \cos(\theta) \cos(\phi) - E_\phi \sin(\phi) \quad (V/m) \quad (6.24)$$

$$E_y = E_\theta \cos(\theta) \sin(\phi) + E_\phi \cos(\phi) \quad (V/m) \quad (6.25)$$

$$E_z = -E_\theta \sin(\theta) \quad (V/m) \quad (6.26)$$

$$\bar{\sigma}_a(x, y, z) = \frac{\bar{a}_x E_x + \bar{a}_y E_y + \bar{a}_z E_z}{\sqrt{|E(x, y, z)|^2}} \quad (\text{dimensionless}) \quad (6.27)$$

In (6.27), ( $\bar{a}_{x,y,z}$ ) are the unit vectors for the Cartesian coordinate system.

The polarization loss factor (PLF) of a bedspring antenna at a point in the far-field for a given incoming wave with unit polarization vector ( $\sigma_w$ ) is expressed as [Ref 3: p. 51];

$$PLF = |\bar{\sigma}_w \cdot \bar{\sigma}_a|^2 \quad (\text{dimensionless}) \quad (6.28)$$

Without knowledge of antenna efficiencies, one cannot exactly predict an antenna's maximum effective aperture ( $A_{em}$ ) or maximum effective height ( $h_{em}$ ). Nonetheless, one may assume a lossless antenna system and approximate these parameters as follows [Ref 2: pp. 29-43]:

$$A_{em} = D_o (PLF) \left( \frac{\lambda^2}{4\pi} \right) \quad (m^2) \quad (6.29)$$

$$h_{em} = 2 \sqrt{\frac{R_r A_{em}}{\eta_o}} \quad (m) \quad (6.30)$$

For a half-wave dipole assembly, such as that pictured in Figure 6.1, a complex current that achieves maximum gain is fed to each element only within a few percent of the frequency ( $f_{\lambda/2}$ ) whose wavelength matches the length of the half-wavelength dipoles. Therefore, the bandwidth (BW) of a Figure 6.1 type bedspring antenna is [Ref 10: p. 21-16]:

$$f_{high} = 1.02 f_{\lambda/2} \quad (HZ) \quad (6.31)$$

$$f_{low} = .98 f_{\lambda/2} \quad (HZ) \quad (6.32)$$

$$BW = f_{high} - f_{low} \quad (HZ) \quad (6.33)$$

In (6.31), ( $f_{high}$ ) is the upper frequency of the antenna. In (6.32), ( $f_{low}$ ) is the lower bound on operating frequency.

If wideband operations are required for a bedspring antenna, a symmetrical feed arrangement as shown Figure 6.3 may be employed.

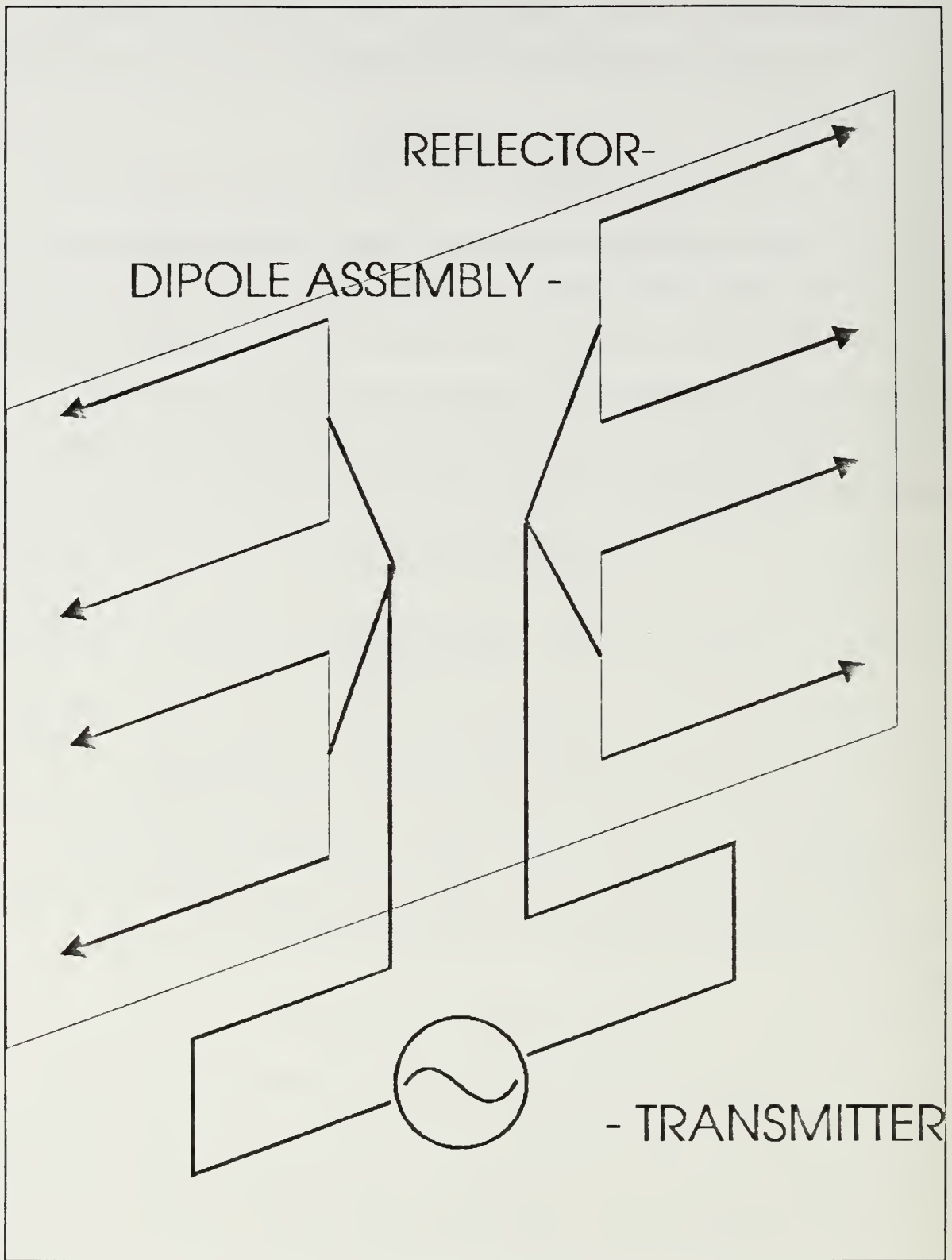

FIGURE 6.3 Symmetrical Feed Bedspring Antenna

The bandwidth for a symmetrical feed bedspring antenna is given by [Ref 10: p. 21-16]:

$$f_{high}=1.5f_{\lambda/2} \quad (HZ) \quad (6.34)$$

$$f_{low}=.98f_{\lambda/2} \quad (HZ) \quad (6.35)$$

$$BW=f_{high}-f_{low} \quad (HZ) \quad (6.36)$$

Figure 6.4 compares the electric field pattern computed by the bedspring antenna Mathcad applications with measured results for a two-bay ( $Y_i=26$  meters), four-stack ( $Z_i=13$  meters) bedspring antenna with reflector ( $X_i=7$  meters) operating at 10 MHz over soil ( $\sigma=.01$  S/m,  $\epsilon_r=10$ ) [Ref 12: p. 115].



### Comparison of Bedspring Antenna Electric Fields

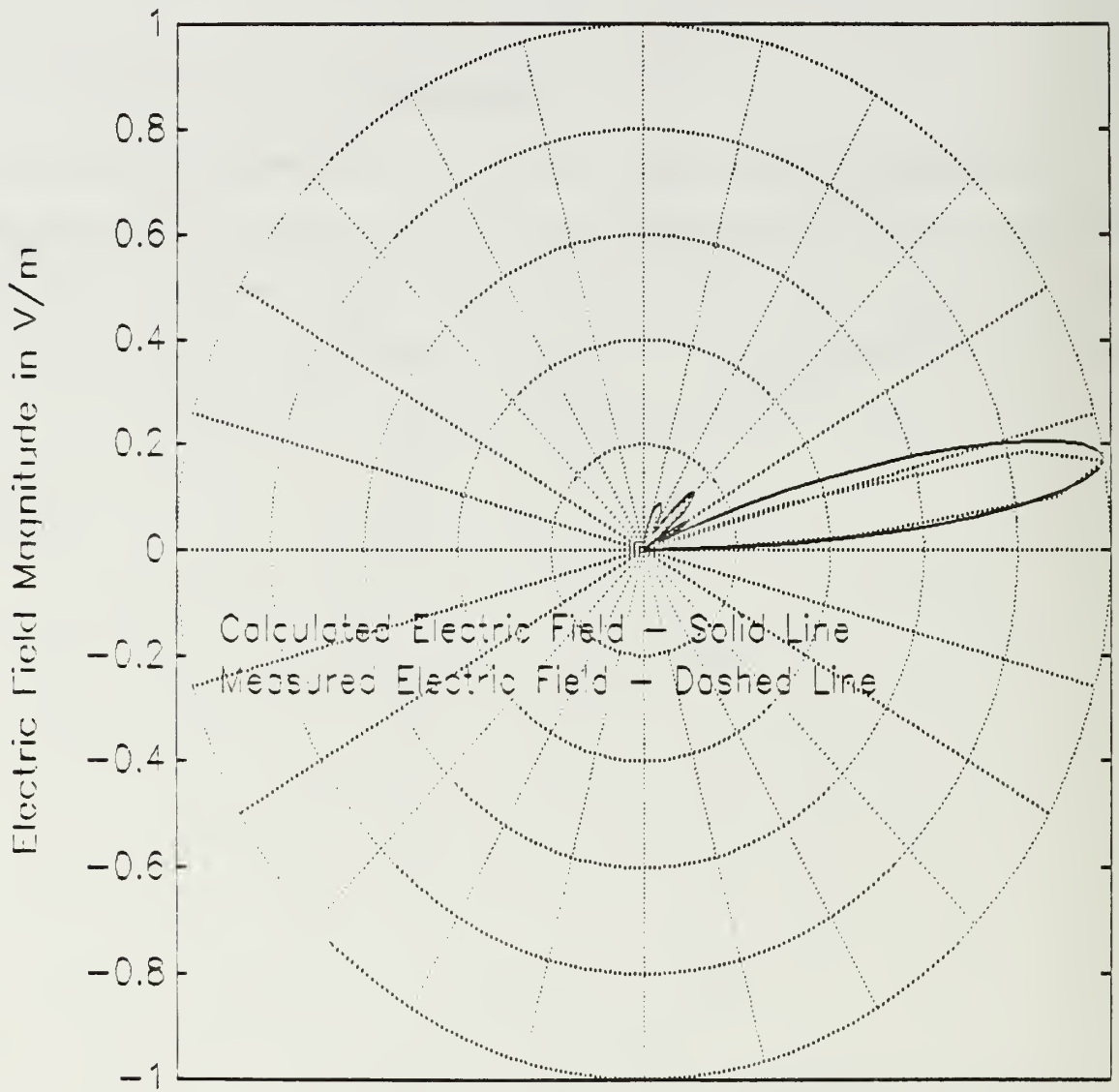

FIGURE 6.4 Bedspring Antenna Electric Field Patterns

## VII. THE SPIRAL ANTENNA

Spiral antennas are a family of two- and three-dimensional structures that maintain a constant input impedance, beam pattern, gain, and polarization as well as many other parameters over a wide range of frequencies. Spiral antennas are commonly referred to as frequency independent, or broadband, devices. A two-dimensional spiral is called a planar spiral, while a three-dimensional spiral is usually termed a conical spiral. Planar and conical spiral antennas are commonly used in applications such as direction finding, missile guidance, and satellite tracking. [Ref 6: pp. 14-2 - 14-3]

Although there are several types of planar and conical spiral antennas, Mathcad applications will fully analyze only those antennas with reasonably simple, closed form equations: equiangular planar spirals and conical log-spirals. Mathcad applications assume that the base of all spirals lies in the x-y plane and is centered at the origin, that the axis of all spirals is parallel to the z axis, and that the spirals are in free space.

### **A. THE PLANAR SPIRAL ANTENNAS**

There are three major categories of planar spiral antennas: the equiangular spiral, the Archimedean spiral, and the log-periodic spiral. The geometry of all planar spirals is pictured in Figure 7.1.

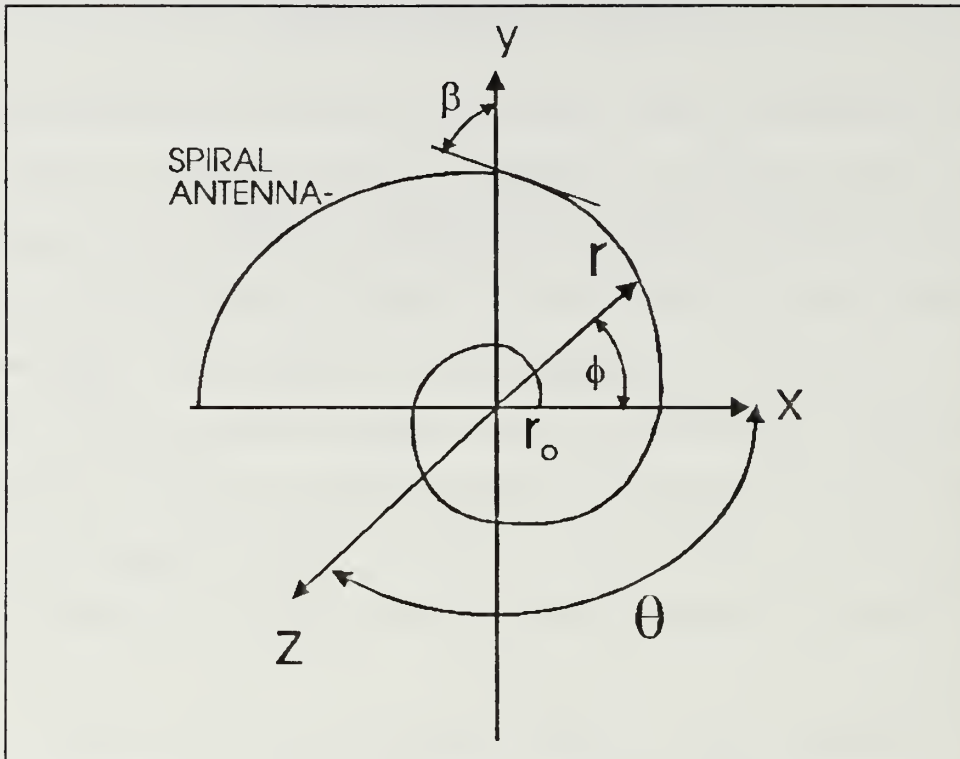

FIGURE 7.1 Planar Spiral Geometry

In Figure 7.1, the spiral angle ( $\beta$ ) is the angle between any radial line from the origin and a tangent to any edge of the spiral, ( $r$ ) is the distance to any point on the spiral from the origin, and ( $r_0$ ) is the distance from the origin to the spiral's feed point. The Mathcad spiral antenna application user should not confuse the radial distance from the origin to any point on the spiral ( $r$ ) and the distance from the origin to an observation point in the far-field ( $r_{ff}$ ).

Spiral antennas may be constructed from wires or sheets of metal. For low power, receive only operations, spirals may also be built using printed circuit technology. A more rugged, all-purpose antenna is constructed by simply cutting the spiral edges

from a sheet of metal and running coaxial feed lines along the spiral arms. A dummy feed line may also be run on an opposing arm for symmetry [Ref 6: pp. 14-4 - 14-7].

The physical dimensions of the spiral arms determine the type of spiral antenna and the antenna's parameters. An equiangular spiral is one whose edges or wires satisfy the following [Ref 5: p. 283]:

$$r=r_0e^{a\phi} \quad (m) \quad (7.1)$$

In (7.1), (a) is an arbitrary constant called the flare rate. If the flare rate is a negative number, the spiral is considered left-handed. If the flare rate is positive, the spiral is right-handed.

When sheet metal is used to construct an equiangular spiral, (7.1) defines the coordinates of one edge of one spiral arm. The next edge ( $r_2$ ) is cut using the same spiral curve as (7.1), but with an angular arm width ( $\delta$ ) as follows:

$$r_2=r_0e^{a(\phi-\delta)} \quad (m) \quad (7.2)$$

Spiral antennas are usually symmetrical. Thus, for a two arm spiral, edges ( $r_3$ ) and ( $r_4$ ) are given by:

$$r_3=r_0e^{a(\phi-\pi)} \quad (m) \quad (7.3)$$

$$r_4=r_0e^{a(\phi-\pi-\delta)} \quad (m) \quad (7.4)$$

Normally, flare rate is converted to a factor called expansion ratio ( $\epsilon_{ex}$ ) which is written as [Ref 5: p.284]:

$$e_{ex} = \frac{r(\phi + 2\pi)}{r(\phi)} \quad (\text{dimensionless}) \quad (7.5)$$

A typical value for the expansion ratio is 4.

The Archimedean spiral has many of the same characteristics as the equiangular spiral, except that any point on the edge of an Archimedean spiral is written as:

$$r = r_o \phi \quad (m) \quad (7.6)$$

Likewise, the performance of a log-periodic spiral is similar to an equiangular spiral except that its edges are defined by:

$$r = r_o a^\phi \quad (m) \quad (7.7)$$

For a log-periodic spiral it can be shown that the following formula is always satisfied [Ref 2: pp. 697-698]:

$$\phi = \tan(\beta) \ln(r) \quad (\text{radians}) \quad (7.8)$$

In (7.8), the spiral angle ( $\beta$ ) is the same as that illustrated in Figure 7.1 and is constant at any point on the log-periodic structure. Because of their broadband characteristics and ease of construction, log-periodic spirals are regularly used in the lower millimeter wave region [Ref 12: p. 17-28].

The lowest operating frequency ( $f_{low}$ ), highest operating frequency ( $f_{high}$ ), and bandwidth (BW) of spirals are functions of the antenna's dimensions and the feed arrangement. For equiangular and Archimedean devices, the minimum radius ( $r_o$ ) and wavelength of the highest operating frequency are approximately

correlated as follows [Ref 5: pp. 284-285]:

$$r_o \approx \frac{\lambda_{high}}{4} \quad (m) \quad (7.9)$$

The wavelength ( $\lambda_{low}$ ) corresponding to the lowest operating frequency is set by the overall radius (R) of the structure as follows:

$$R = \frac{\lambda_{low}}{4} \quad (m) \quad (7.10)$$

With the antenna's upper and lower frequency limits established, bandwidth may be expressed as:

$$BW = f_{high} - f_{low} \quad (Hz) \quad (7.11)$$

The frequency limits and bandwidth of a log-periodic spiral are also determined by its dimensions. Bandwidth of a log periodic spiral is given by (7.11), where the lower frequency limit corresponds to the wavelength computed using (7.10) and the upper frequency's wavelength is calculated as follows [Ref 2: p. 700]:

$$r_o = \frac{\lambda_{high}}{20} \quad (m) \quad (7.12)$$

A spiral antenna is frequency independent in that most antenna parameters do not vary over the bandwidth of the antenna, which can be a considerable range of frequencies. Input impedance is one of these parameters and may be computed using the concept of complimentary antennas. The complement of a spiral is formed by replacing metal with air and air with metal.



The impedances of the spiral and its complement are ( $Z_{metal}$ ) and ( $Z_{air}$ ), respectively. These two impedances are real, frequency independent, and for a two-arm spiral related as follows [Ref 5: p. 283]:

$$Z_{metal}Z_{air} = \frac{\eta_o^2}{4} \quad (\Omega^2) \quad (7.13)$$

In (7.13), ( $\eta_o$ ) is the intrinsic impedance of free space. If the antenna and its complement are identical, the antenna is called self-complimentary and the angular arm width in (7.2) is  $\pi/2$ . In the specific case of a two-arm, self-complimentary spiral, the impedance of the antenna is:

$$Z_{metal} = Z_{air} = \frac{\eta_o}{2} = 188.5 \quad (\Omega) \quad (7.14)$$

Self-complimentary spirals are fairly common because they yield desirable radiation patterns. Measured input impedance is typically between 120-160 ohms for these devices, which is lower than the theoretical results of (7.14). The presence of a feed structure, the finite size of the antenna, and the finite thickness associated with the spiral's arms are the reasons measured input impedance is lower than its theoretical value [Ref 5: pp. 285-286].

Mathcad spiral antenna applications assume that planar spirals are equiangular and self-complimentary. The applications also assume that input impedance for a two-arm spiral is given by (7.14).



An (N) arm, rotationally symmetric spiral has (N-1) independent radiation modes, where each mode corresponds to a different radiation pattern. Typically, an (N) arm spiral operating in mode (M) excites each arm with a current of identical magnitude. The phase difference ( $\alpha$ ) with respect to the first arm for arm (n) of an (N) arm spiral excited in mode (M) is given by [Ref 6: p. 14-4]:

$$\alpha = \frac{-2\pi nM}{N} \quad (\text{radians}) \quad (7.15)$$

Most of the radiation from a spiral occurs at the point where the spiral's circumference (C) equals the product of the mode and wavelength of the frequency of interest. As frequency and wavelength change, the principal radiation point on the antenna changes but the radiation parameters and beam patterns do not. The shifting radiation point along the structure is why spirals are broadband antennas. In addition, as long as the spiral is sufficiently large to radiate all desired frequencies, the shape of the spiral arm termination does not effect the antenna's radiation pattern [Ref 6: pp. 14-4 - 14-7].

All modes of a planar spiral whose center is at the origin in the x-y plane have a null along the z axis, unless mode one is being excited. A planar spiral radiates in both positive and negative z half spaces with magnitude patterns that are rotationally symmetric.

The electric field of a self-complimentary, planar spiral at an observation point in the far-field is given by [Ref 14: p.

530]:

$$E_{\theta} = E_{\tau} = 0 \quad (V/m) \quad (7.16)$$

$$E_{\phi} = \frac{E_o k^3 \cos(\theta) [1 + j a \cos(\theta)]^{-1-j(M/a)} [\tan(\frac{\theta}{2})]^M}{\sin(\theta)^2} \quad (7.17)$$

$$* \frac{e^{j(M(\theta + \frac{\pi}{2}) - k r_{ff})}}{I_{ff}} e^{-jM\phi} \quad (V/m)$$

In (7.16) and (7.17), ( $E_o$ ) is a source strength constant and ( $k$ ) is the wavenumber given by:

$$k = \frac{2\pi}{\lambda} \quad (m^{-1}) \quad (7.18)$$

Rearranging (7.17), the amplitude of the electric field ( $A_{\phi}$ ) becomes:

$$A_{\phi} = \frac{\cos(\theta) [\tan(\frac{\theta}{2})]^M e^{\frac{M}{a} \tan^{-1}(a \cos(\theta))}}{\sin(\theta) \sqrt{1+a^2 [\cos(\theta)]^2}} \quad (V/m) \quad (7.19)$$

The Mathcad application user should note the phase variation as a function of azimuth in (7.17). This phase variation can result in azimuthal beam shaping if multiple spirals are used in an array [Ref 15: p. 18]. However, for a single spiral there is no change in electric field magnitude with azimuth and the pattern is considered rotationally symmetric.

The electric field computed using (7.17) or (7.19) applies only in the far-field. Therefore, the following conditions must all hold if the far-field patterns are to be accurate [Ref 3: p. 92]:

$$r_{ff} \geq 1.6\lambda \quad (m) \quad (7.20)$$

$$r_{ff} \geq 10R \quad (m) \quad (7.21)$$

$$r_{ff} \geq \frac{8R^2}{\lambda} \quad (m) \quad (7.22)$$

With the spiral's electric field given by (7.16) and (7.17), the antenna's radiation intensity ( $U$ ), radiated power ( $P_{rad}$ ), and directivity ( $D_o$ ) are found using generic antenna formulas as follows [Ref 3: pp. 28-29]:

$$U = \frac{r_{ff}^2}{2\eta_o} |E_\phi|^2 \approx \frac{1}{2\eta_o} |A_\phi|^2 \quad (W/solid\ ang) \quad (7.23)$$

$$P_{rad} = \iint_{\Omega} U \sin(\theta) d\theta d\phi \quad (W) \quad (7.24)$$

$$D_o = \frac{4\pi U_{max}}{P_{rad}} \quad (dimensionless) \quad (7.25)$$

In (7.24), ( $\Omega$ ) is the entire sphere of radius ( $r_{ff}$ ) in the far-field that surrounds the spiral. In (7.25), ( $U_{max}$ ) is the maximum radiation intensity anywhere on the sphere.

The gain ( $G$ ) of a spiral is the product of its directivity and efficiencies. Conduction-dielectric efficiency ( $\epsilon_{cd}$ ) of a spiral cannot be easily determined and is, therefore, assumed by the Mathcad applications to be unity. Reflection efficiency ( $\epsilon_{rv}$ ), however, can be approximated. The impedance of a two arm, self-complimentary spiral is given by (7.14). In the general case of an ( $N$ ) arm, self-complimentary spiral in free space

operating in mode (M), the input impedance is real and is given by [Ref 6: p. 14-22]:

$$Z_i = N \frac{30\pi}{\sin(\pi \frac{M}{N})} \quad (\Omega) \quad (7.26)$$

If the characteristic impedance ( $Z_0$ ) of the feed line is known or can be estimated, the voltage reflection coefficient ( $\Gamma$ ), reflection efficiency, and gain are computed by:

$$\Gamma = \frac{Z_i - Z_0}{Z_i + Z_0} \quad (\text{dimensionless}) \quad (7.27)$$

$$\epsilon_{rv} = 1 - |\Gamma|^2 \quad (\text{dimensionless}) \quad (7.28)$$

$$G = \epsilon_{rv} D_0 \quad (\text{dimensionless}) \quad (7.29)$$

The planar spiral radiates in both directions normal to its surface. Improvements to antenna gain can be realized if the radiation in the undesired direction is reflected or eliminated. A common technique used to achieve an improvement in gain is to place a cylindrical metal cavity on the side of the spiral that has the unwanted beam pattern. The cavity can improve gain by up to 4.5 dB but can also reduce bandwidth by up to a factor of 5. The loss of bandwidth can be mitigated by filling the cavity with electromagnetic energy absorbing material. The absorbing material will reduce gain for spiral with a cavity by up to 1.5 dB depending on thickness of the material and dimensions of the cavity. Although Mathcad applications do not include cavity parameters, the effect of cavities on antenna gain can be

estimated using measured results from an archimedean cavity-backed spiral. The change of overall gain with cavity depth and maximum gain with cavity diameter are pictured in Figures 7.2 and 7.3, respectively [Ref 6: pp. 14-17 - 14-18].

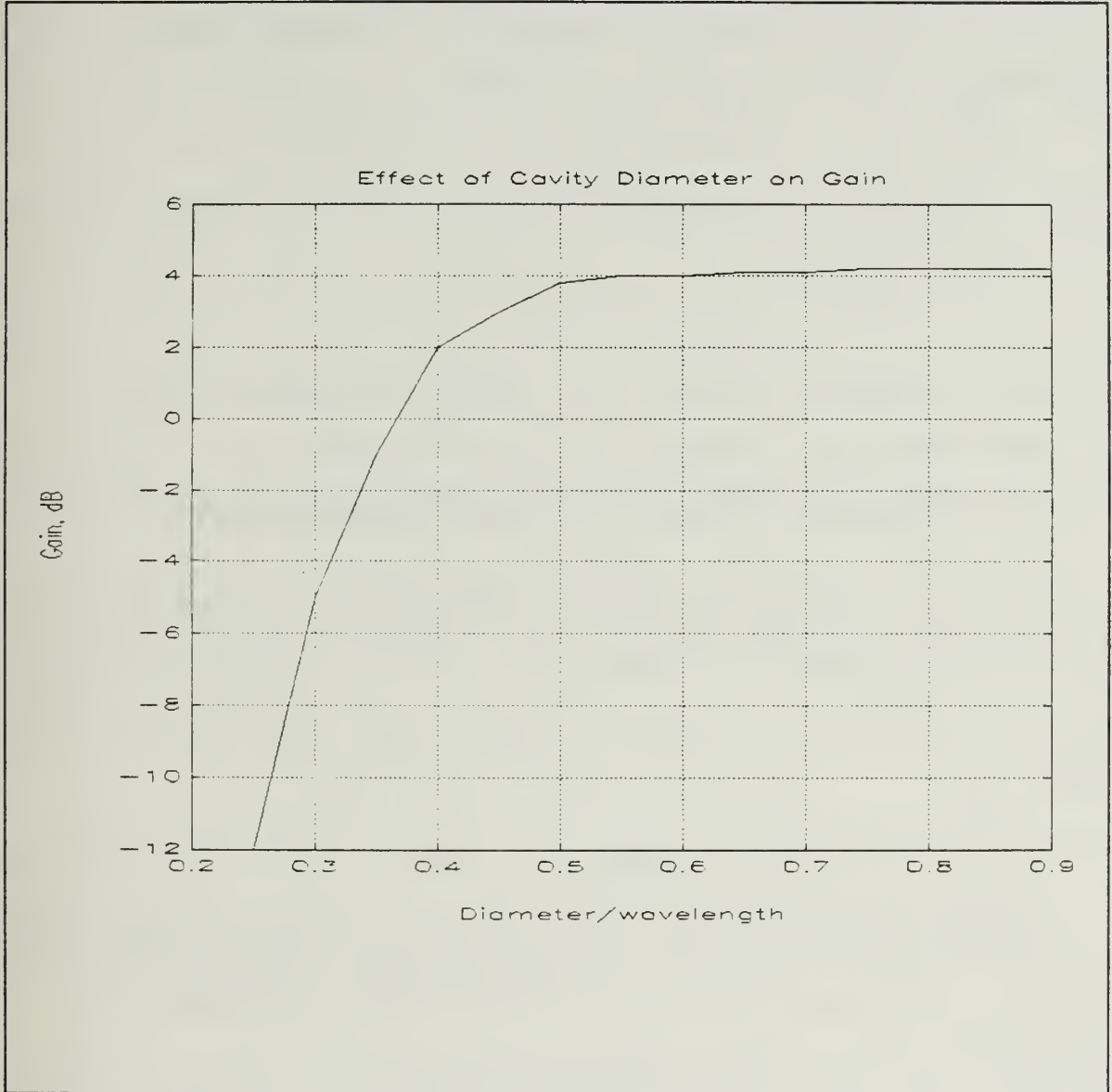

FIGURE 7.3 Effect of Cavity Diameter on Gain

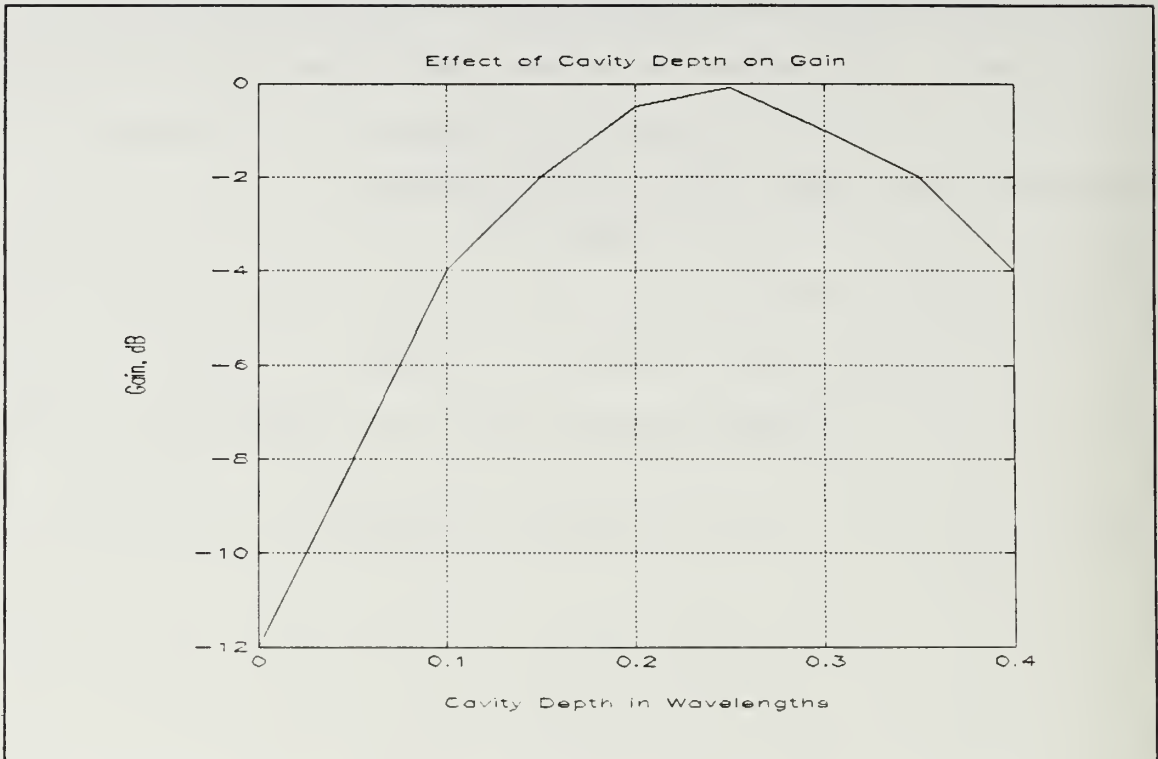

FIGURE 7.2 Effect of Cavity Depth on Gain

Effective isotropic radiated power (EIRP) is the product of gain (dimensionless) and power delivered to the input of the antenna. Effective isotropic radiated power for a planar spiral is given by:

$$EIRP = P_{rad} D_o \quad (W) \quad (7.30)$$

If the magnitude of the current ( $I_o$ ) at the antenna's feed is known, its radiation resistance ( $R_r$ ) may be expressed as:

$$R_r = \frac{2P_{rad}}{|I_o|^2} \quad (\Omega) \quad (7.31)$$

The spiral antenna Mathcad application user should note that the magnitude of the transmitter current cannot be estimated from the



antenna's dimensions and is normalized to unity.

The polarization of a planar spiral whose center is the origin is circular within 70° of the z axis. The handedness of the spiral's polarization is the same as the spiral if measured in the +z half-space and if the spiral is excited at the central feed point. If the polarization is measured in the -z half-space or if the spiral is fed at its peripheral termination, the handedness of polarization is opposite that of the spiral. Dual polarization is achieved when the structure is simultaneously excited at both the center and periphery [Ref 6: p. 14-20].

Mathcad applications assume that a planar spiral's unit polarization vector ( $\sigma_a$ ) is circular, although the user may modify this according to observed feed structures. If the incoming wave unit polarization vector ( $\sigma_w$ ) can be determined, the polarization loss factor (PLF) of the antenna is calculated as [Ref 3: p. 51]:

$$PLF = |\vec{\sigma}_w \cdot \vec{\sigma}_a^*|^2 \quad (\text{dimensionless}) \quad (7.32)$$

With all efficiency and loss terms computed, the antenna's maximum effective aperture ( $A_{em}$ ) and maximum effective height ( $h_{em}$ ) are estimated as follows [Ref 3: p. 63]:

$$A_{em} = \epsilon_{rv} D_o (PLF) \left( \frac{\lambda^2}{4\pi} \right) \quad (m^2) \quad (7.33)$$

$$h_{em} = 2 \sqrt{\frac{R_r A_{em}}{\eta_o}} \quad (m) \quad (7.34)$$

Figure 7.4 illustrates the difference between the electric



field pattern computed by the spiral antenna Mathcad applications and measured results for an equiangular spiral antenna ( $a=.3$ ,  $\delta=90^\circ$ ,  $r_o=.005$  meters,  $R=.142$  meters) operating at 2.8 GHz over a conducting plane [Ref 16: p.185].

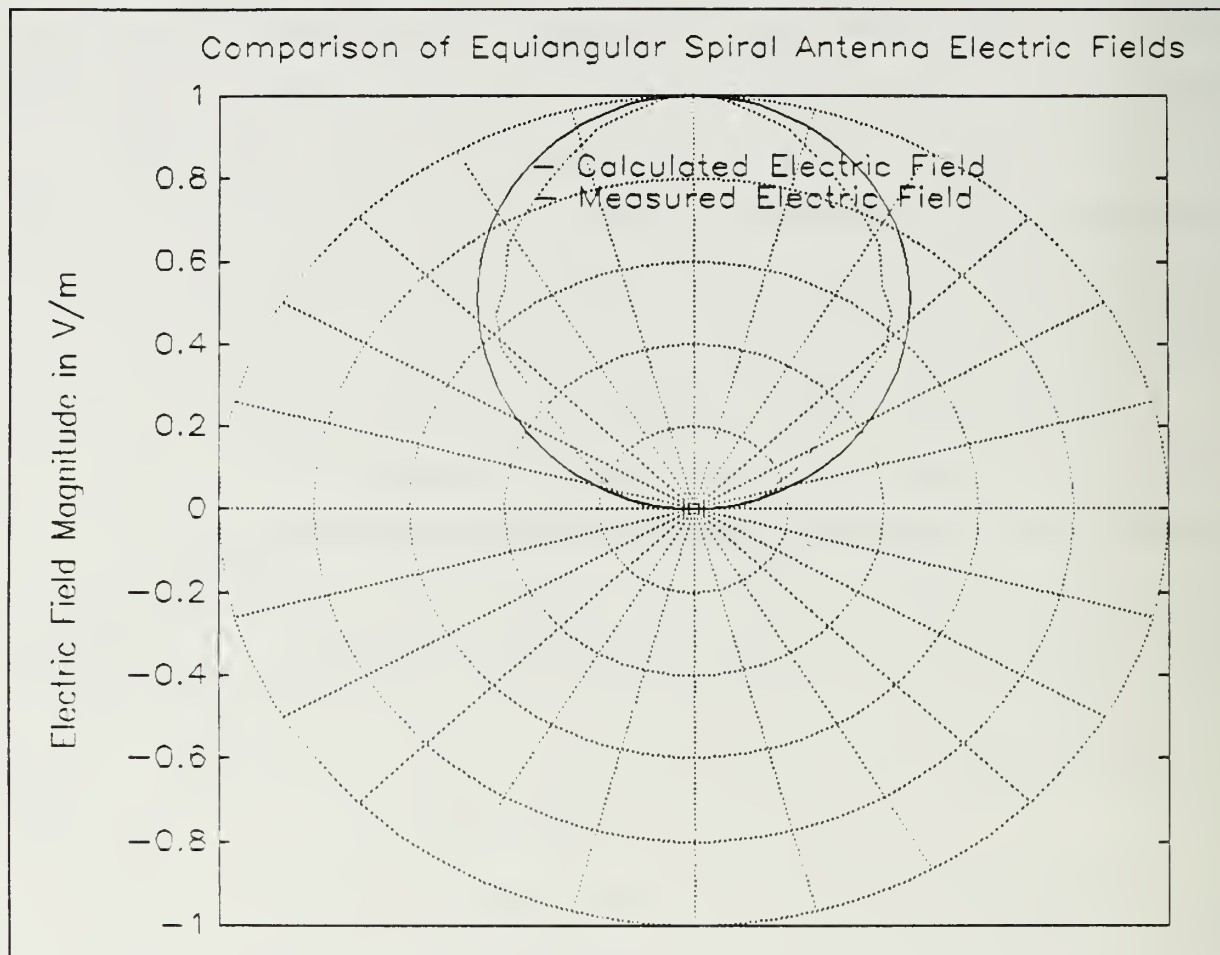

FIGURE 7.4 Equiangular Spiral Electric Field Patterns

## B. THE CONICAL SPIRAL ANTENNA

The planar spiral antenna offers many features which make it a very popular device. However, the fact that it radiates in a direction normal to both of its surfaces is a major drawback.

Although cylindrical cavities placed on one side of the spiral can reduce the effects of unwanted radiation, a modification to the basic planar structure can accomplish the same result without additional apparatus. If the planar spiral is altered into a conical shape, many of the desirable features of the planar spiral are maintained, but radiation occurs primarily in direction of the cone's tip.

Any point on the  $i^{\text{th}}$  edge of a log-conical spiral antenna may be defined by [Ref 5: p. 286]:

$$r_i = r_o e^{(b \sin \theta_o) (\phi - \delta_i)} \quad (m) \quad (7.35)$$

In (7.35),  $(\delta_i)$  is the angular offset of the  $i^{\text{th}}$  edge,  $(\theta_o)$  is the conical half-angle, and  $(b)$  is an arbitrary constant given by:

$$b = \cot(\beta) \quad (\text{dimensionless}) \quad (7.36)$$

The geometry of a log-spiral is illustrated in Figure 7.5.

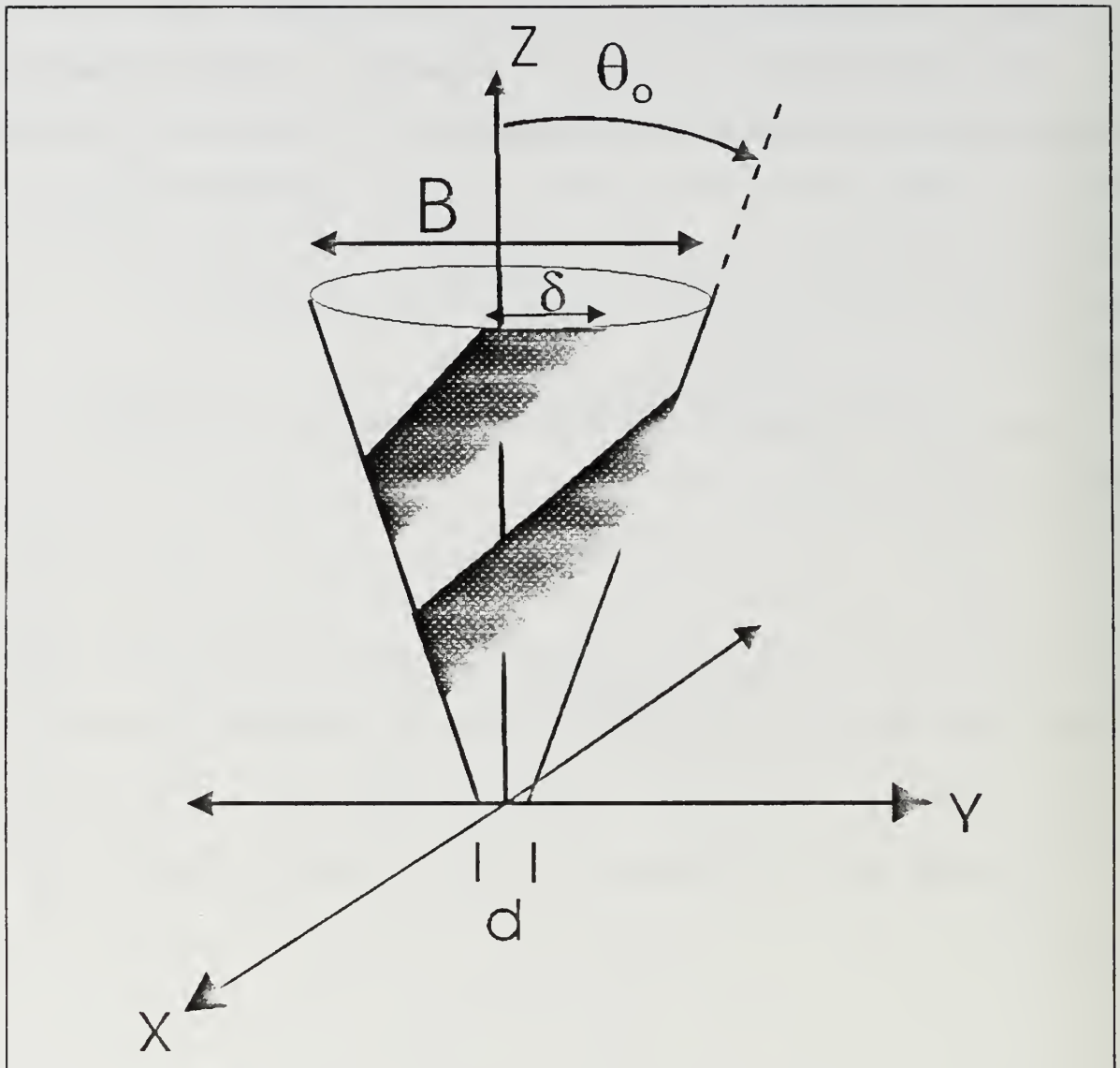

FIGURE 7.5 Conical Log-Spiral Geometry

In Figure 7.5, (B) is the overall diameter or twice the overall radius (R) and (d) is twice the feed radius ( $r_0$ ).

Analogous to the planar spiral, the upper operating frequency ( $f_{\text{high}}$ ) of a conical log-spiral is determined by the relationship between the wavelength ( $\lambda_{\text{high}}$ ) of the upper frequency and the spacing (d) between feed points as follows [Ref 5: p.

287]:

$$d = \frac{\lambda_{high}}{4} \quad (m) \quad (7.37)$$

The lower operating frequency ( $f_{low}$ ) of the conical spiral is determined by the correlation between the lower frequency's wavelength ( $\lambda_{low}$ ) and the antenna's overall diameter by [Ref 5: p. 287]:

$$B = \frac{3\lambda_{low}}{8} \quad (m) \quad (7.38)$$

The bandwidth of the conical log-spiral is computed using (7.11).

The conical log-spiral radiates a single lobe in the direction of its apex. The pattern broadens with increasing spiral angle ( $\beta$ ) and lowering cone angle ( $2\theta_0$ ) until irregularities occur and multiple beams begin to form. Figure 7.6 provides a rapid reference for the boundary between usable and unusable cone and spiral angles. [Ref 13: pp. 9-84 - 9-85]

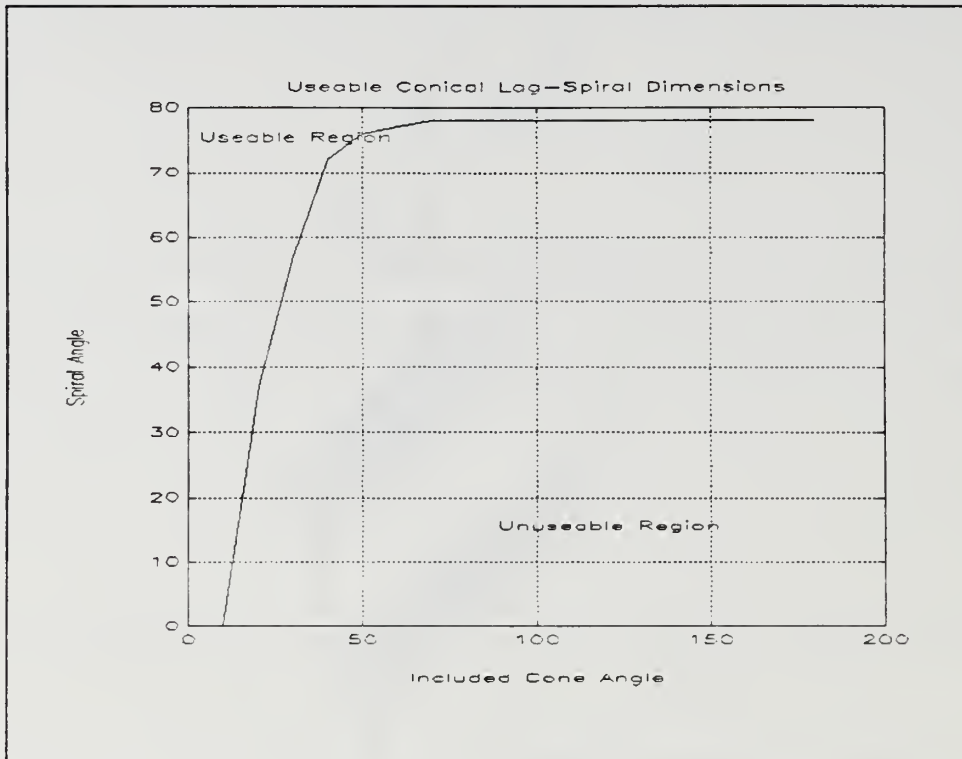

FIGURE 7.6 Conical Log-Spiral Useable Dimensions

The far-field electric field components of a conical log-spiral of total arm length ( $L$ ) are written as follows [Ref 17: pp. 321-331]:

$$E_r = 0 \quad (V/m) \quad (7.39)$$

$$E_\theta = -j f \mu_0 \frac{e^{-jk r_{ff}}}{2 r_{ff} Q} \int_0^L I(\xi) e^{\frac{jk\xi}{Q} \cos(\theta) \cos(\theta_0)} A(\xi) d\xi \quad (V/m) \quad (7.40)$$

$$E_\phi = f \mu_0 \frac{e^{-jk r_{ff}}}{2 r_{ff} Q} \int_0^L I(\xi) e^{\frac{jk\xi}{Q} \cos(\theta) \cos(\theta_0)} B(\xi) d\xi \quad (V/m) \quad (7.41)$$

In (7.40) and (7.41), the slowness factor of the antenna ( $Q$ ) and the total arm length of a spiral arm ( $L$ ) are constants defined by:

$$Q = \sqrt{1 + \frac{1}{b^2}} \quad (\text{dimensionless}) \quad (7.42)$$

$$L = \frac{r_o}{b} [e^{(\phi_L) b \sin(\theta_o)} - 1] \quad (m) \quad (7.43)$$

In (7.43),  $(\phi_L)$  is the azimuth at the end of the spiral arm and is:

$$\phi_L = \frac{1}{b \sin(\theta_o)} \ln \left( \frac{R}{r_o} \right) \quad (\text{radians}) \quad (7.44)$$

The coefficients  $A(\xi)$  and  $B(\xi)$  of equations (7.40) and (7.41), respectively, are expressed as:

$$A(\xi) = \sum_{l=0}^{N-1} e^{-jMl\alpha} e^{\frac{jk\xi}{Q} \sin(\theta) \sin(\theta_o) \cos(\phi(\xi) - \phi - l\alpha)} \cdot \left[ \frac{\sin(\theta_o) \cos(\theta) C(\xi)}{2} - \sin(\theta) \cos(\theta_o) \right] \quad (\text{dimensionless}) \quad (7.45)$$

$$B(\xi) = \sum_{l=0}^{N-1} e^{-jMl\alpha} e^{\frac{jk\xi}{Q} \sin(\theta) \sin(\theta_o) \cos(\phi(\xi) - \phi - l\alpha)} * \left( \frac{-j \sin(\theta_o)}{2} \right) C(\xi) \quad (\text{dimensionless}) \quad (7.46)$$

In (7.45) and (7.46),  $(\alpha)$  and  $C(\xi)$  are given by:

$$\alpha = \frac{2\pi}{N} \quad (\text{dimensionless}) \quad (7.47)$$

$$C(\xi) = \left( 1 + \frac{j}{b \sin(\theta_o)} \right) e^{j(\phi(\xi) - \phi - l\alpha)} \pm \left( 1 - \frac{j}{b \sin(\theta_o)} \right) * e^{-j(\phi(\xi) - \phi - l\alpha)} \quad (\text{dimensionless}) \quad (7.48)$$

The (+) sign in (7.48) is for  $C(\xi)$  used in calculating  $(E_\theta)$ , while the (-) sign is for  $(E_z)$  computations.

Azimuth angle as a function of distance along the spiral arm ( $\phi(\xi)$ ) in (7.45), (7.46), and (7.48) is calculated using:

$$\phi(\xi) = \frac{1}{b \sin(\theta_o)} \ln\left(\frac{\xi b}{r_o} + 1\right) \quad (\text{radians}) \quad (7.49)$$

The current distribution ( $I(\xi)$ ) used in (7.40) and (7.41) is that of the excitation current along the spiral arm. This current distribution can only be calculated using intricate numerical modeling or a method of moments solution. An examination of measured current distribution yields the following engineering approximation of ( $I(\xi)$ ) given a current at the feed point of ( $I_o$ ):

$$I(\xi) = I_o e^{-\frac{\xi^2}{L}} \quad (\text{Amps}) \quad (7.50)$$

Figure 7.7 provides a comparison of the current distribution computed by the conical log-spiral Mathcad applications using (7.50) to that measured for a four arm conical log-spiral ( $\theta_o=10^\circ$ ,  $\delta=20^\circ$ ,  $b=.46$ ) operating in mode one. The application user should note that most of the radiation from the conical log-spiral occurs at the location on the device where arm length ( $L$ ) in wavelengths approximately equals the mode number [Ref 17: pp. 321-331].



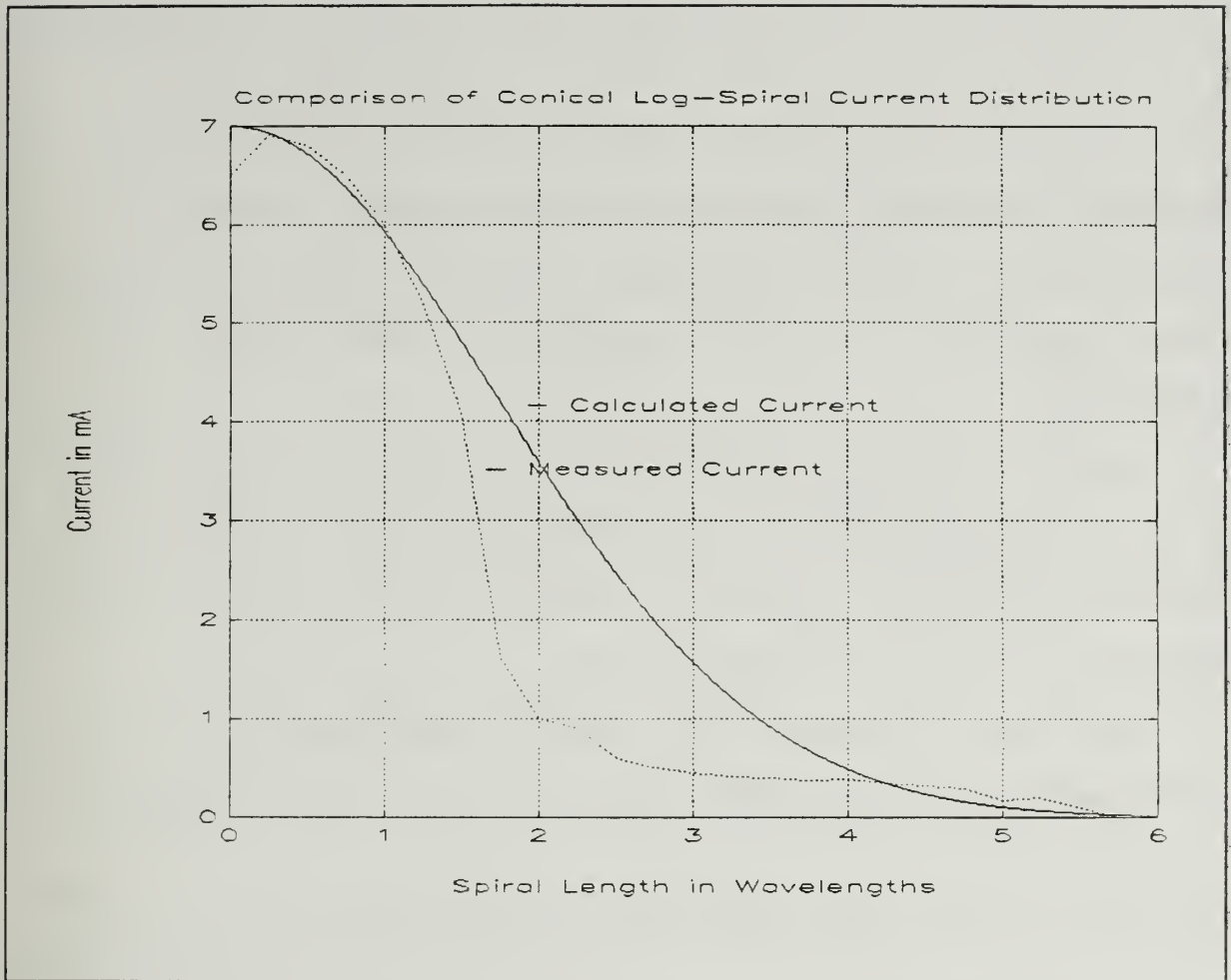

FIGURE 7.7 Conical Log-Spiral Current Distributions

Mathcad spiral antenna application users should note the precise evaluation of the integrals in (7.40) and (7.41) is very time consuming, even on a 33 MHz, 386 personal computer. Thus, the application user is provided a trapezoidal approximation to evaluate the conical log-spiral antenna integrals. Also, both the exact and trapezoidal applications only analyze electric fields and other parameters in the +z half- plane.

In the trapezoidal approximation, the integral is replaced by a summation and  $(d\xi)$  is replaced by:

$$d\xi \approx \frac{L}{t} \quad (m) \quad (7.51)$$

In (7.51), (t) is an operator entered number of spiral arm increments. The application user should expect the Mathcad evaluation of a conical log-spiral using the trapezoidal method to take about 25% of the time required for exact method predictions.

Conical log-spiral electric field calculations are valid only if the conditions of (7.20) through (7.22) are satisfied. Mathcad applications assume that overall radius is the largest dimension of the conical log-spiral.

Radiation intensity of the conical log-spiral antenna is determined by [Ref 3: p. 28]:

$$U = \frac{r_{ff}^2}{2\eta_0} [ |E_\theta|^2 + |E_\phi|^2 ] \quad (W/solid \text{ ang}) \quad (7.52)$$

The radiated power and directivity of the conical log-spiral are given by (7.24) and (7.25). Users of the Mathcad spiral antenna application should be aware that computer solution of these formulas may be very time consuming. However, one may reasonably consider most conical log-spiral antennas in the useable region of Figure 7.6 to have a total electric field that is rotationally symmetric with respect to the antenna's axis. Given this fact, an approximation of directivity may be made. An estimate of half-power beamwidth ( $\Delta\theta$ ) in degrees as a function of spiral and cone angles is provided in Figure 7.8 below.

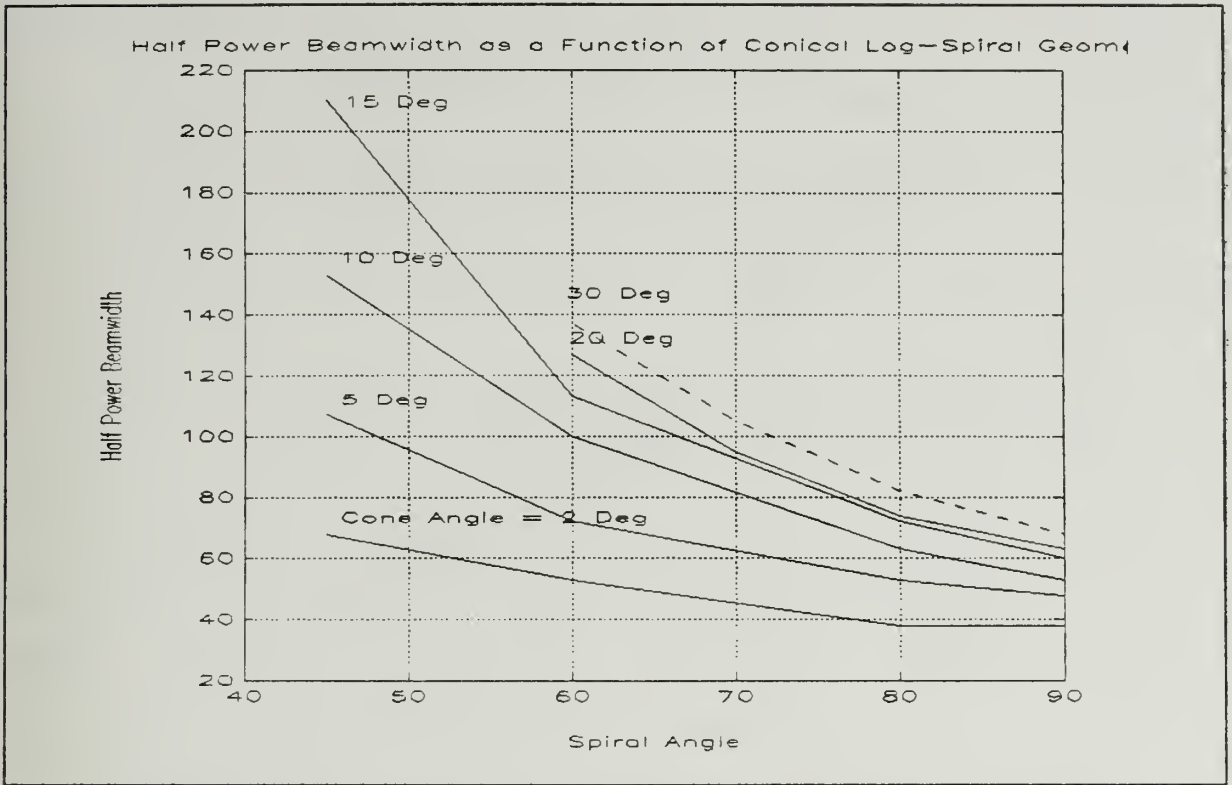

FIGURE 7.8 Conical Log-Spiral Half\_Power Beamwidths

The half-power beamwidth from Figure 7.8 is used to estimate directivity by [Ref 13: p. 9-87]:

$$D_o \approx \frac{32600}{(\Delta\theta)^2} \quad (dB) \quad (7.53)$$

It is impossible to accurately determine the conduction-dielectric efficiency of a conical log-spiral antenna based solely on measured geometry of the antenna. Hence, the Mathcad conical log-spiral applications assume all conduction dielectric efficiency is unity. The input impedance ( $Z_1$ ) of a conical log-spiral antenna as a function of angular arm width is provided in Figure 7.9.

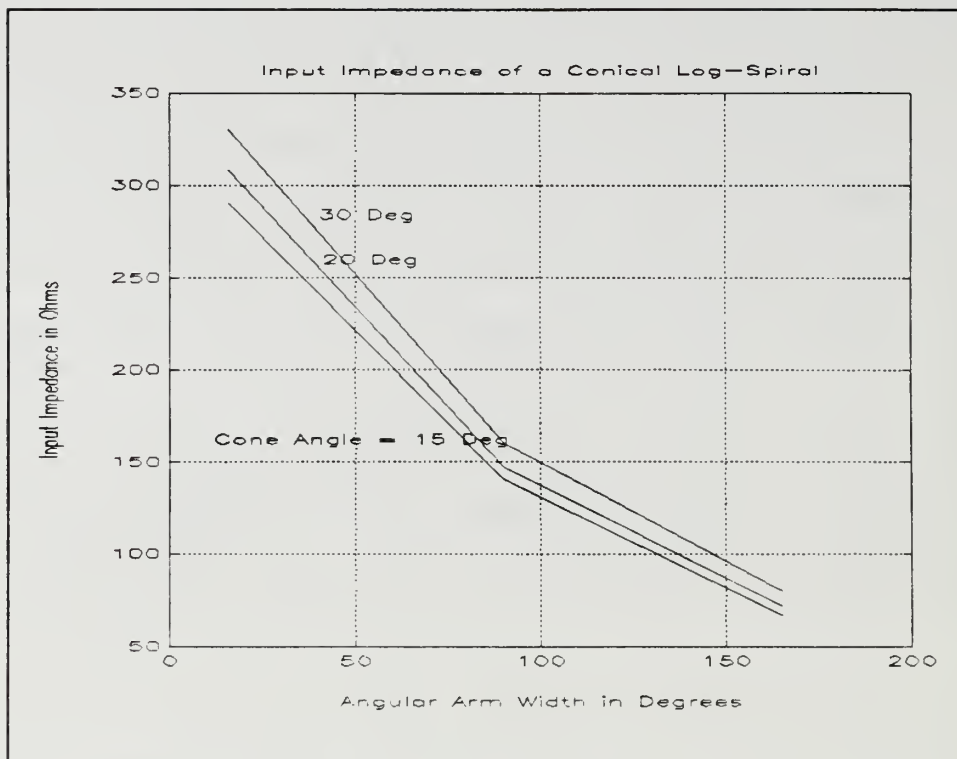

FIGURE 7.9 Input Impedance of a Conical Log-Spiral

Using the input impedance from Figure 7.9 and an estimate of the characteristic impedance of the feed assembly, the Mathcad conical log-spiral antenna application user may compute voltage reflection coefficient, reflection efficiency, gain, and effective isotropic radiated power using (7.27), (7.28), (7.29), and (7.30), respectively.

If the polarization unit vector ( $\sigma_w$ ) of an incoming wave is known, precise determination of polarization loss at a point in the far-field may be desired. To accomplish this, Mathcad applications convert electric field components of (7.40) and (7.41) to Cartesian coordinates at a user defined point ( $x, y, z$ ) and compute the antenna's unit polarization vector ( $\sigma_a$ ) as

follows [Ref 4: pp. 35-36, 364-367]:

$$E_x = E_\theta \cos(\theta) \sin(\phi) - E_\phi \sin(\phi) \quad (V/m) \quad (7.54)$$

$$E_y = E_\theta \cos(\theta) \sin(\phi) + E_\phi \cos(\phi) \quad (V/m) \quad (7.55)$$

$$E_z = -E_\theta \sin(\theta) \quad (V/m) \quad (7.56)$$

$$\bar{\sigma}_a(x, y, z) = \frac{\bar{a}_x E_x + \bar{a}_y E_y + \bar{a}_z E_z}{\sqrt{|E(x, y, z)|^2}} \quad (\text{dimensionless}) \quad (7.57)$$

The conical log-spiral antenna's polarization loss factor is calculated using (7.32). Using the polarization loss factor, maximum effective aperture ( $A_{em}$ ) and maximum effective height ( $h_{em}$ ) for a conical log-spiral are given by:

$$A_{em} = \epsilon_{rv} D_o \left( \frac{\lambda^2}{4\pi} \right) PLF \quad (m^2) \quad (7.58)$$

$$h_{em} = 2 \sqrt{\frac{R_r A_{em}}{Z_o}} \quad (m) \quad (7.59)$$

Figure 7.10 and Table 7.1 compare measured data to that calculated by the Mathcad applications for a two arm, mode one conical log-spiral ( $b=.053$ ,  $\theta_o=10^\circ$ ,  $\alpha=73^\circ$ ,  $d=.03$  meters,  $B=.30$  meters,  $\delta=90^\circ$ ) operating at 350 MHz [Ref 18: p. 332].

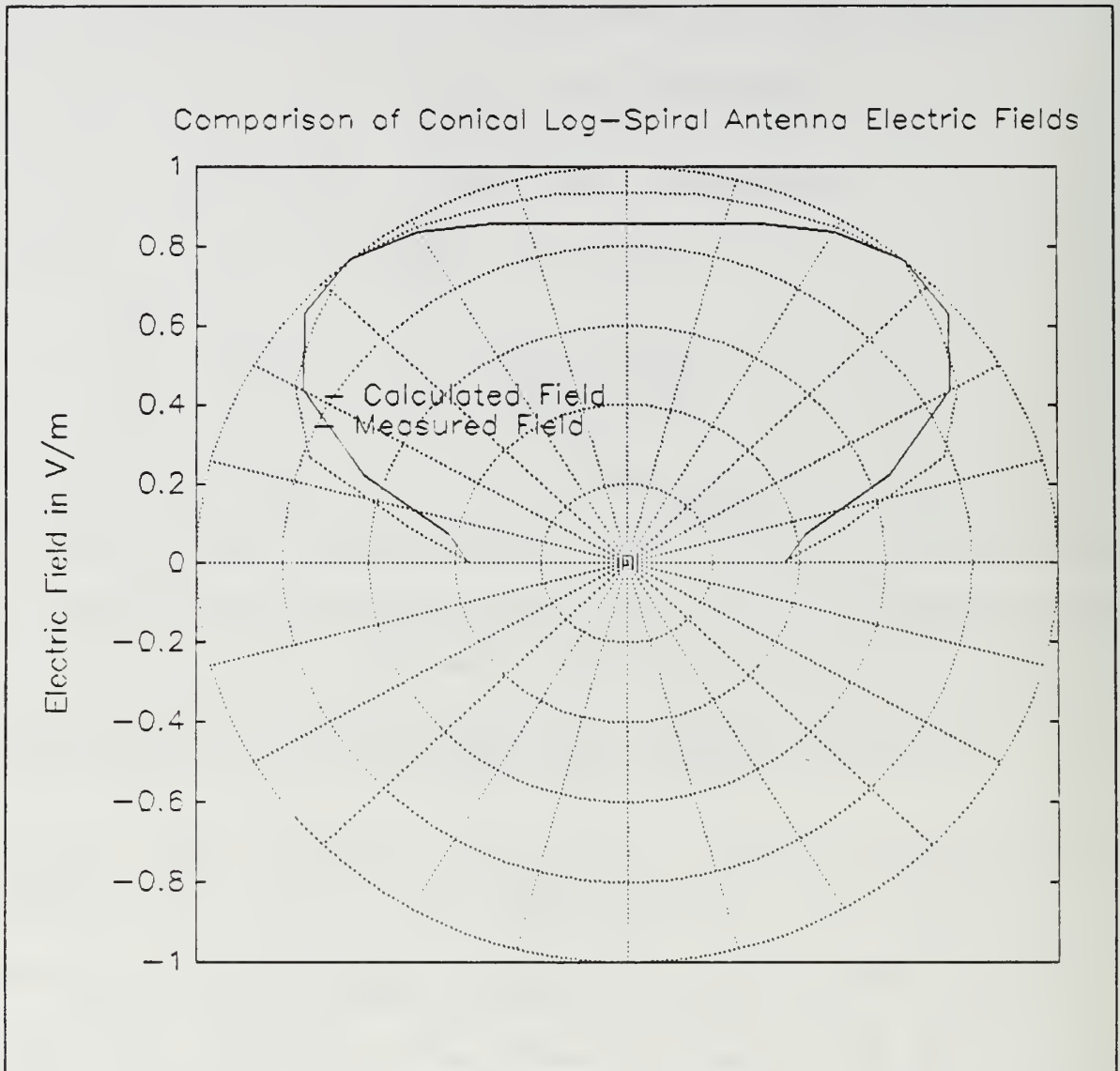

FIGURE 7.10 Conical Log-Spiral Electric Field Pattern

TABLE 7.1 Conical Log-Spiral Data Comparison

ANTENNA PARAMETER	MEASURED DATA	CALCULATED DATA
DIRECTIVITY	6.10 dB	6.03 dB



### VIII. THE CONICAL HORN ANTENNA

The conical horn antenna is a device that provides a transition for an electromagnetic wave from a circular waveguide to an unbounded medium such that the wavefront phase at the horn's aperture is nearly constant [Ref 2: pp. 644-645]. As a result of its axial symmetry, the conical horn's radiation pattern is strictly a function of the cone's geometry for a given mode of excitation [Ref 10: p. 10-3]. The conical horn is widely employed as a feed element for reflector assemblies used in satellite tracking, microwave communications, and radar. The geometry of a conical horn is illustrated in Figure 8.1.

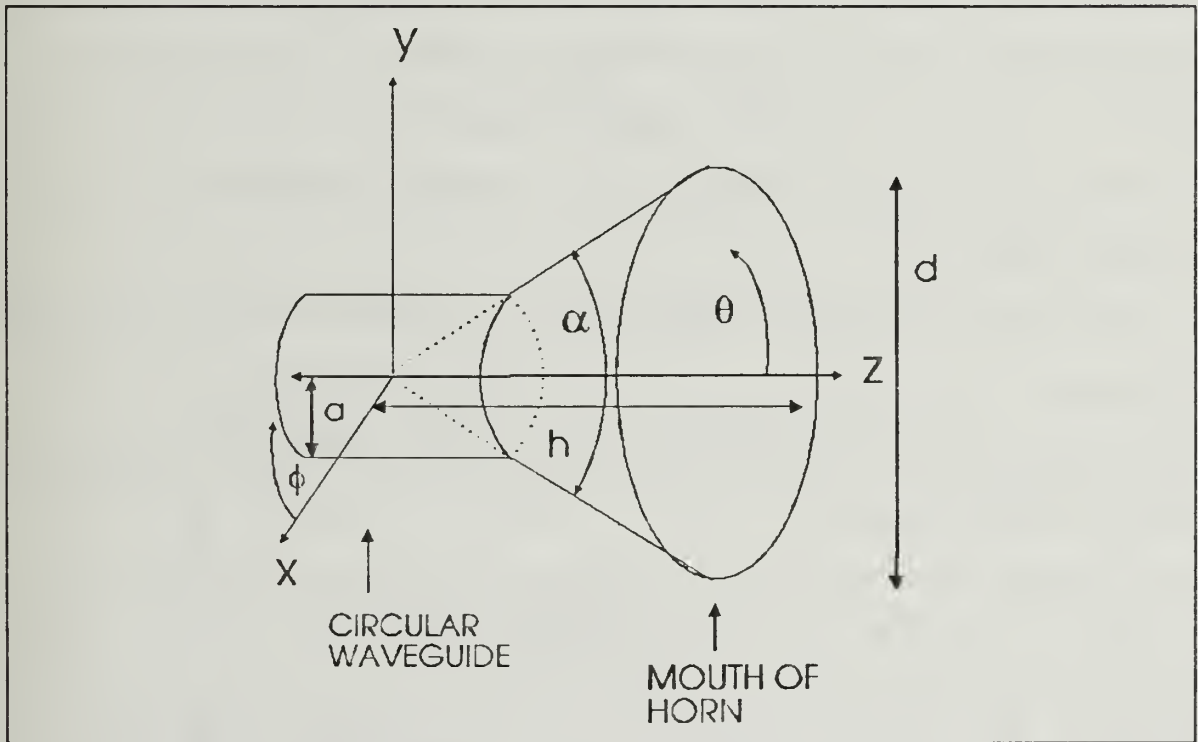

FIGURE 8.1 Conical Horn Geometry

In Figure 8.1, (a) is the inner radius of the circular waveguide, flare angle ( $\alpha$ ) is the included angle of the horn, (d) is the



diameter of the mouth of the horn, and the axial height (h) is the distance from the origin to the center of the mouth of the horn.

A circular waveguide will only propagate a transverse electric (TE) or transverse magnetic (TM) mode of an electromagnetic wave if the frequency of the wave is above a minimum value for the mode called the cutoff frequency ( $f_c$ ). The propagating mode with the lowest cutoff frequency is called the dominant mode. For circular waveguides the ( $TE_{11}$ ) mode is the dominant mode [Ref 4: p.570]. Mathcad conical horn antenna applications assume that the waveguide is excited only in the dominant ( $TE_{11}$ ) mode. Also, the applications do not compute bandwidth for conical horn antennas. Rather, the software computes cutoff frequencies for selected modes such that the user can determine if the waveguide will support propagation of a specific mode.

Each mode's cutoff frequency is a function of the circular waveguide's inner radius. For transverse electric waves, the cutoff frequency of an air filled circular waveguide is given by [Ref 19: pp. 472-473]:

$$(f_c)_{m,n} = \frac{\chi'_{mn}}{2\pi a \sqrt{\mu_o \epsilon_o}} \quad (Hz) \quad (8.1)$$

In (8.1), ( $\mu_o$ ) is the permeability of free space, ( $\epsilon_o$ ) is permittivity of free space, and ( $\chi'_{mn}$ ) is the  $n^{\text{th}}$  zero of the derivative with respect to the argument of the Bessel function of

the first kind, order  $m$ .  $(\chi'_{mn})$  may be obtained from Table 8.1.

**TABLE 8.1** Zeroes of the Bessel Function Derivative

$\chi'_{mn}$	m=0	m=1	m=2	m=3	m=4
n=1	3.8318	1.8412	3.0542	4.2012	5.3175
n=2	7.0156	5.3315	6.7062	8.0153	9.2824
n=3	10.1735	8.5363	9.9695	11.3459	12.6819
n=4	13.3237	11.7060	13.1704	14.5859	15.9641

The cutoff frequency of transverse magnetic waves in an air filled circular waveguide is written as [Ref 19: pp. 478-479]:

$$(f_c)_{m,n} = \frac{\chi_{mn}}{2\pi a \sqrt{\mu_o \epsilon_o}} \quad (\text{Hz}) \quad (8.2)$$

In (8.2),  $(\chi_{mn})$  is the  $n^{\text{th}}$  zero of the Bessel function of the first kind, order  $m$ .  $(\chi_{mn})$  may be obtained from Table 8.2.

**TABLE 8.2** Zeros of the Bessel Function

$\chi_{mn}$	m=0	m=1	m=2	m=3	m=4
n=1	2.4049	3.8318	5.1357	6.3802	7.5884
n=2	5.5201	7.1056	8.4173	9.7610	11.0647
n=3	8.6537	10.1735	11.6199	13.0152	14.3726
n=4	11.7915	13.3237	14.7960	16.2235	17.6160

A conical horn is said to be optimum if the diameter of the mouth of the horn satisfies the following [Ref 10: p. 10-9]:

$$d = \frac{3}{2} \lambda \sin\left(\frac{\alpha}{2}\right) \quad (m) \quad (8.3)$$

To allow for comparison between the antenna being evaluated and an optimum horn, the conical horn Mathcad applications calculate optimum (d) for a user provided frequency of interest and horn flare angle.

The electric field calculations of the conical horn Mathcad applications use the magnetic field integral equation solution for aperture antennas. This is similar to the combined field integral equation solution first postulated by Schorr and Beck for conical horns in 1950 [Ref 20: p. 795]. The application user can expect a large amount of computer processing time will be necessary to analyze a conical horn and that this time will grow with the **square** of the number of increments (i) into which the far-field is divided.

In order to compute the magnetic vector potential (A) of the aperture field of a conical horn, several preliminary functions and related constants must first be defined. These include associated Legendre functions of the first kind of order (v) [ $P_\nu^{(m)} \cos(\theta)$ ], spherical Hankel functions of the second kind of order (v) [ $h_\nu^{(2)}(kr)$ ], and the derivative with respect to (kr) of the spherical Hankel functions [ $h'_{\nu}{}^{(2)}(kr)$ ]. The arguments of the spherical Hankel functions are (r), the distance from the origin to an observation point in the far-field, and the wavenumber (k)

for a wavelength ( $\lambda$ ) corresponding to a frequency of interest. Wavenumber is given by:

$$k = \frac{2\pi}{\lambda} \quad (m^{-1}) \quad (8.4)$$

The order ( $\nu$ ) of the Legendre and Hankel functions may be approximated using the constant ( $b_0$ ) as follows [Ref 21: p. 521]:

$$b_0 = \frac{\log\left[\frac{(1-\frac{\alpha}{\pi})}{4}\right]}{\log\left[\cos\left(\frac{\alpha}{2}\right)\right]} \quad (\text{dimensionless}) \quad (8.5)$$

$$\nu = -.5 + .5\sqrt{1+4b_0} \quad (\text{dimensionless}) \quad (8.6)$$

The associated Legendre function of the first kind with  $m=1$  may be estimated using the gamma function ( $\Gamma(z)$ ) for angles less than ( $\pi/3$ ) as follows [Ref 22: pp. 336]:

$$P_\nu^{(1)}(\cos(\theta)) \approx \frac{\Gamma(\nu+2)}{\Gamma(\nu+1.5)} \left[ \sqrt{\frac{\pi}{2} \sin(\theta)} \right] \cos\left((\nu+.5)\theta + \frac{\pi}{4}\right) \quad (8.7)$$

(dimensionless)

The value of the spherical Hankel function and its derivative with respect to its argument in the far-field may be estimated by [Ref 17 p. 796]:

$$h_\nu^{(2)}(kr) \approx \frac{1}{kr} e^{-j(kr - \frac{(\nu+1)}{2}\pi)} \quad (\text{dimensionless}) \quad (8.8)$$

$$h_\nu^{(2)'}(kr) \approx \frac{1}{kr} e^{-j(kr - \frac{(\nu\pi)}{2})} \left[ 1 - j \frac{(\nu+1)}{kr} \right] \quad (\text{dimensionless}) \quad (8.9)$$

The components of the magnetic vector potential are given by

[Ref 20: p.798]:

$$\begin{aligned}
 A_x = & -B_H \int_0^{\frac{\alpha}{2}} \int_0^{2\pi} e^{jkh\cos(\beta)} \\
 & * [\sin(\delta\theta') P_v(\cos(\theta_o)) \cos^2(\phi') \cos(\theta')] \\
 & + \frac{\delta\cos(\delta\theta')}{\sin(\theta')} P_v(\cos(\theta_o)) \sin^2(\phi') \sin^2(\theta')] \\
 & * d\theta' d\phi' \text{ (Wb/m)}
 \end{aligned} \tag{8.10}$$

$$\begin{aligned}
 A_y = & -B_H \int_0^{\frac{\alpha}{2}} \int_0^{2\pi} e^{jkh\cos(\beta)} \\
 & * [\sin(\delta\theta') P_v(\cos(\theta_o)) \cos(\phi') \sin(\phi') \cos(\theta')] \\
 & - \frac{\delta\cos(\delta\theta')}{\sin(\theta')} P_v(\cos(\theta_o)) \sin(\phi') \cos(\theta') \sin^2(\theta')] \\
 & * d\theta' d\phi' \text{ (Wb/m)}
 \end{aligned} \tag{8.11}$$

$$\begin{aligned}
 A_z = & B_H \int_0^{\frac{\alpha}{2}} \int_0^{2\pi} e^{jkh\cos(\beta)} \\
 & * [\sin(\delta\theta') P_v(\cos(\theta_o)) \cos(\phi') \sin(\theta')] d\theta' d\phi' \\
 & \text{(Wb/m)}
 \end{aligned} \tag{8.12}$$

The integrals in (8.10) through (8.12) are performed over the aperture of the horn, thus the primed components in these integrals indicate source coordinates. The terms  $\cos(\beta)$ ,  $(\delta)$ , and  $(B_H)$  in the magnetic vector potential integrals are given by:

$$\begin{aligned}
 \cos(\beta) = & \cos(\theta) \cos(\theta') + \sin(\theta) \sin(\theta') \cos(\phi - \phi') \\
 & \text{(dimensionless)}
 \end{aligned} \tag{8.13}$$

$$\delta = \frac{\pi}{\alpha} \text{ (dimensionless)} \tag{8.14}$$

$$B_H = B_o \frac{h^2}{j(2\pi)^2 f \epsilon_o r} e^{-jkr} \left[ \frac{1}{h} h_v^{(2)}(kh) + kh_v^{(2)'}(kh) \right] \text{ (Wb/m)} \tag{8.15}$$

In (8.15),  $(B_o)$  is an amplitude scaling constant. The magnetic vector potential integrals contained in (8.10) through

(8.12) include approximations of the associated Legendre function and its first derivative with respect to  $\cos(\theta')$  as follows [Ref 20: p.798]:

$$P_v^{(1)} \cos(\theta') \approx \sin(\delta\theta') P_v^{(1)} \cos\left(\frac{\alpha}{2}\right) \quad (\text{dimensionless}) \quad (8.16)$$

$$P_v^{(1)'} \cos(\theta') \approx -\frac{\delta \cos(\delta\theta')}{\sin(\theta')} P_v^{(1)} \cos\left(\frac{\alpha}{2}\right) \quad (\text{dimensionless}) \quad (8.17)$$

Far-field electric field components are approximated by converting the magnetic vector potential components to spherical coordinates and multiplying by  $(k^2)$  as follows [Ref 3: pp. 92, 102]:

$$A_\theta = A_x \cos(\theta) \cos(\phi) + A_y \cos(\theta) \sin(\phi) - A_z \sin(\theta) \quad (\text{Wb/m}) \quad (8.18)$$

$$A_\phi = -A_x \sin(\phi) + A_y \cos(\phi) \quad (\text{Wb/m}) \quad (8.19)$$

$$E_\theta = k^2 A_\theta \quad (\text{V/m}) \quad (8.20)$$

$$E_\phi = k^2 A_\phi \quad (\text{V/m}) \quad (8.21)$$

For the electric field components of (8.20) and (8.21) to be valid, the observation point  $(r)$  must be in the far-field. Therefore, assuming the diameter of the mouth of the horn is the largest dimension of the cone, all of the following formulas must be satisfied [Ref 3: p.92]:



$$r \geq 1.6\lambda \quad (m) \quad (8.22)$$

$$r \geq 5d \quad (m) \quad (8.23)$$

$$r \geq \frac{2d^2}{\lambda} \quad (m) \quad (8.24)$$

When investigating the parameters of a conical horn antenna with the magnetic field integral equation, it must be presumed that no electric field exists behind the mouth of the horn. Thus, radiation intensity ( $U$ ), radiated power ( $P_{rad}$ ), and directivity ( $D_o$ ) of the conical horn antenna are calculated by applying generic antenna formulas as follows:

$$U = \frac{r^2}{2\eta_o} [ |E_\theta|^2 + |E_\phi|^2 ] \quad (W/solid\ ang) \quad (8.25)$$

$$P_{rad} = \int_0^{2\pi} \int_0^{\frac{\pi}{2}} U \sin(\theta) d\theta d\phi \quad (W) \quad (8.26)$$

$$D_o = \frac{4\pi U_{max}}{P_{rad}} \quad (dimensionless) \quad (8.27)$$

In (8.25), ( $\eta_o$ ) is the intrinsic impedance of free space and in (8.26), ( $U_{max}$ ) is the maximum radiation intensity from the antenna. For a conical horn, it may be reasonably assumed that maximum radiation intensity occurs along the antenna's axis (i.e.,  $\theta=0$ ,  $\phi=0$ ).

In order to lower the computer processing time of the conical horn Mathcad applications, the user may choose a file that uses a trapezoidal approximation of the integrals in (8.10)



through (8.12) and (8.26). The user may also vary the number of trapezoidal increments ( $t_1, t_2, t_3$ ) to vary the extent of this approximation and to adjust computation time.

The ohmic losses of conical horns and their associated circular waveguides are very difficult to precisely determine, but are normally very small. Likewise, reflection efficiency of a conical horn cannot be easily found using analytical techniques, but when measured for horns with moderate flare angles and high directivity it is usually close to unity. The conical horn antenna Mathcad applications approximate the product of ohmic and reflection efficiencies as 0.95 and compute antenna gain (G) and effective isotropic radiated power (EIRP) by [Ref 10: p. 10-9]:

$$G = .95D_o \quad (\text{dimensionless}) \quad (8.28)$$

$$EIRP = P_{rad}D_o \quad (W) \quad (8.29)$$

The unit polarization vector ( $\sigma_a$ ) in Cartesian coordinates of a conical horn's wave may be computed at any point in the far-field as follows [Ref 4: pp. 35-40, 364-367]:

$$E_x = E_\theta \cos(\theta) \cos(\phi) - E_\phi \sin(\phi) \quad (V/m) \quad (8.30)$$

$$E_y = E_\theta \cos(\theta) \sin(\phi) + E_\phi \cos(\phi) \quad (V/m) \quad (8.31)$$

$$E_z = -E_\theta \sin(\theta) \quad (V/m) \quad (8.32)$$

$$\bar{\sigma}_a(x, y, z) = \frac{\bar{a}_x E_x + \bar{a}_y E_y + \bar{a}_z E_z}{\sqrt{|E(x, y, z)|^2}} \quad (\text{dimensionless}) \quad (8.33)$$

If an incoming wave's unit polarization vector ( $\vec{\sigma}_w$ ) is known or can be estimated, the polarization loss factor (PLF) of the antenna at a point in the far-field can be expressed as [Ref 3: p. 51]:

$$PLF = |\vec{\sigma}_w \cdot \vec{\sigma}_a^*|^2 \quad (\text{dimensionless}) \quad (8.34)$$

The maximum effective aperture of a conical horn may be determined as follows [Ref 3: p.63]:

$$A_{em} = .95 D_o (PLF) \left( \frac{\lambda^2}{4\pi} \right) \quad (m^2) \quad (8.35)$$

The actual value of current ( $I_o$ ) applied to the input of a conical horn cannot be determined by dimensional information alone. Thus, exact calculation of radiation resistance ( $R_r$ ) is impossible. However, if input current is normalized to one amp, normalized radiation resistance and maximum effective height ( $h_{em}$ ) may be written as [Ref 2: p. 42]:

$$R_r = \frac{2P_{rad}}{|I_o|^2} \quad (\Omega) \quad (8.36)$$

$$h_{em} = 2 \sqrt{\frac{R_r A_{em}}{\eta_o}} \quad (m) \quad (8.37)$$

A conical horn is a member of a group of devices known as aperture antennas. A term frequently used to analyze the performance of aperture antennas is aperture efficiency ( $\epsilon_{ap}$ ). Aperture efficiency is the ratio of maximum effective aperture to physical area at the mouth of the horn and is calculated by [Ref

3: p. 475]:

$$\epsilon_{ap} = \frac{A_{em}}{\pi \left(\frac{d}{2}\right)^2} \quad (\text{dimensionless}) \quad (8.38)$$

Aperture efficiency of a conical horn is typically about 50%.

Table 8.3 and Figure 8.2 compare measured data to that calculated by the Mathcad applications for a conical horn (a=.045 meters, h=1.489 meters, d=1.0 meters, and  $\alpha=20^\circ$ ) operating at 1.96 GHz [Ref 22: p.100].

TABLE 8.3 Conical Horn Data Comparison

ANTENNA PARAMETER	MEASURED DATA	CALCULATED DATA
GAIN	22.0 dB	23.6 dB

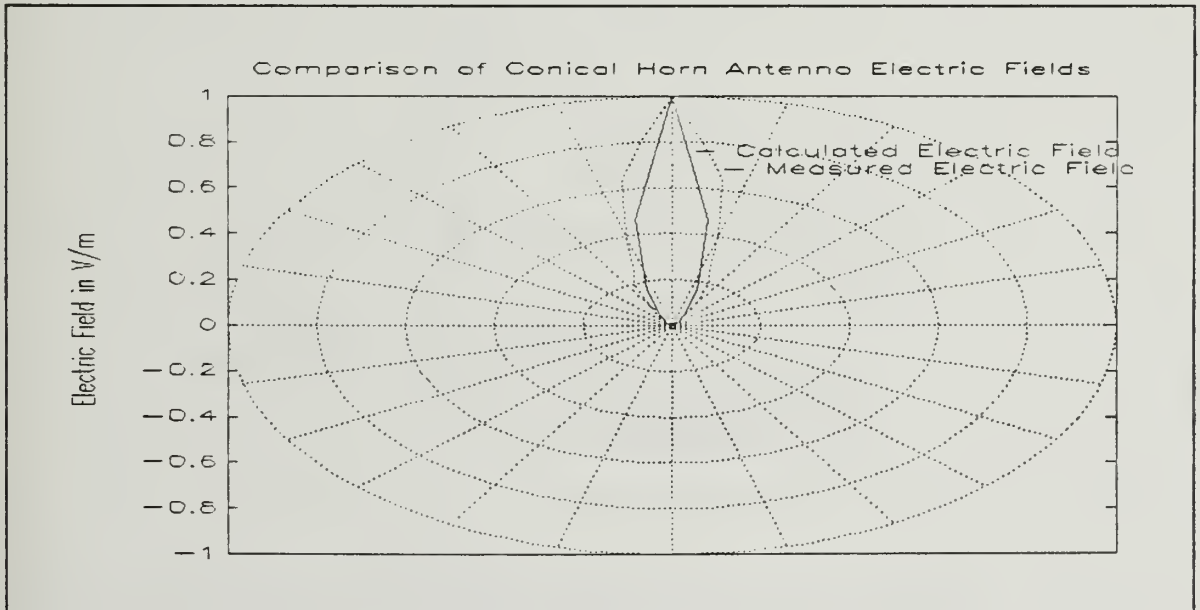

FIGURE 8.2 Conical Horn E-Plane Electric Field Patterns

## IX. THE PYRAMIDAL HORN ANTENNA

The most popular member of the horn family of antennas is the pyramidal horn. The pyramidal horn provides a transition from a rectangular waveguide to free space and is flared both horizontally and vertically. It possesses a radiation pattern that is essentially the combination of that of the E- and H-plane sectoral horns. If accurately constructed, the pyramidal horn offers the ability to control beamwidth in both principal planes with a gain ( $G$ ) that closely matches theoretical predictions [Ref 10: p. 10-3]. The geometry of the pyramidal horn in the E-plane ( $\phi=\pi/2$ ) and H-plane ( $\phi=0$ ) is illustrated in Figures 9.1 and 9.2, respectively.

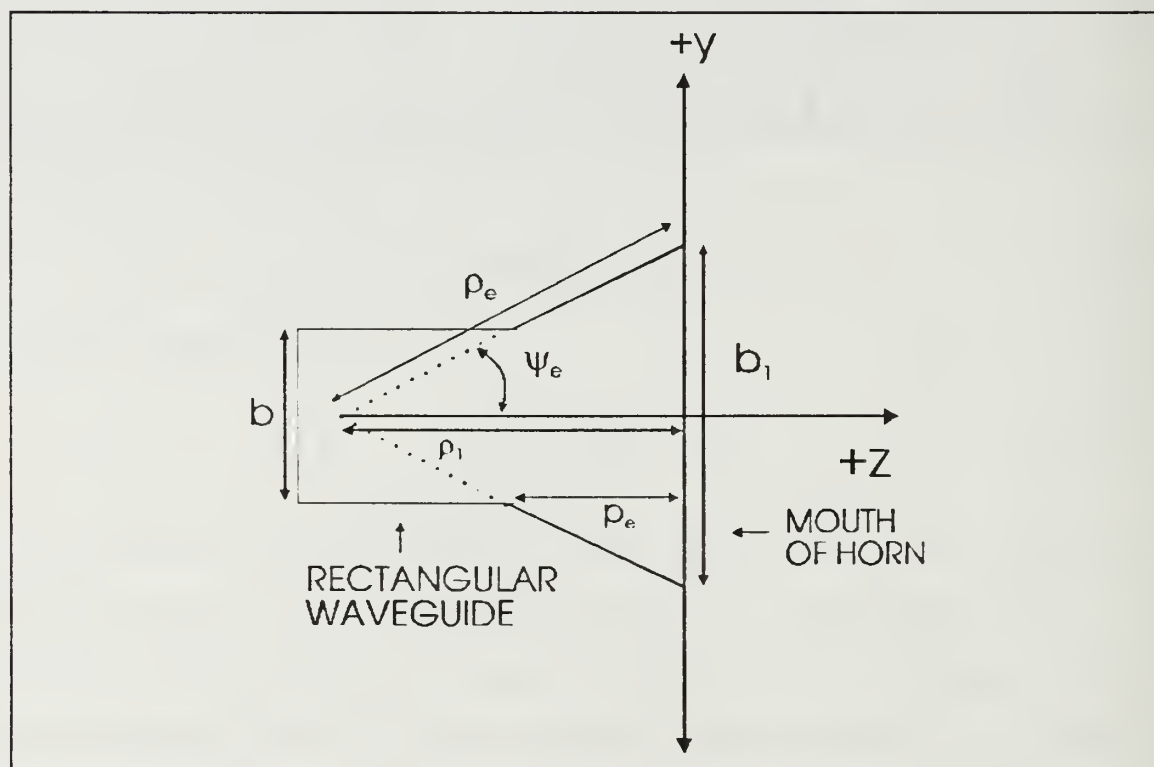

FIGURE 9.1 E-Plane Pyramidal Horn Geometry

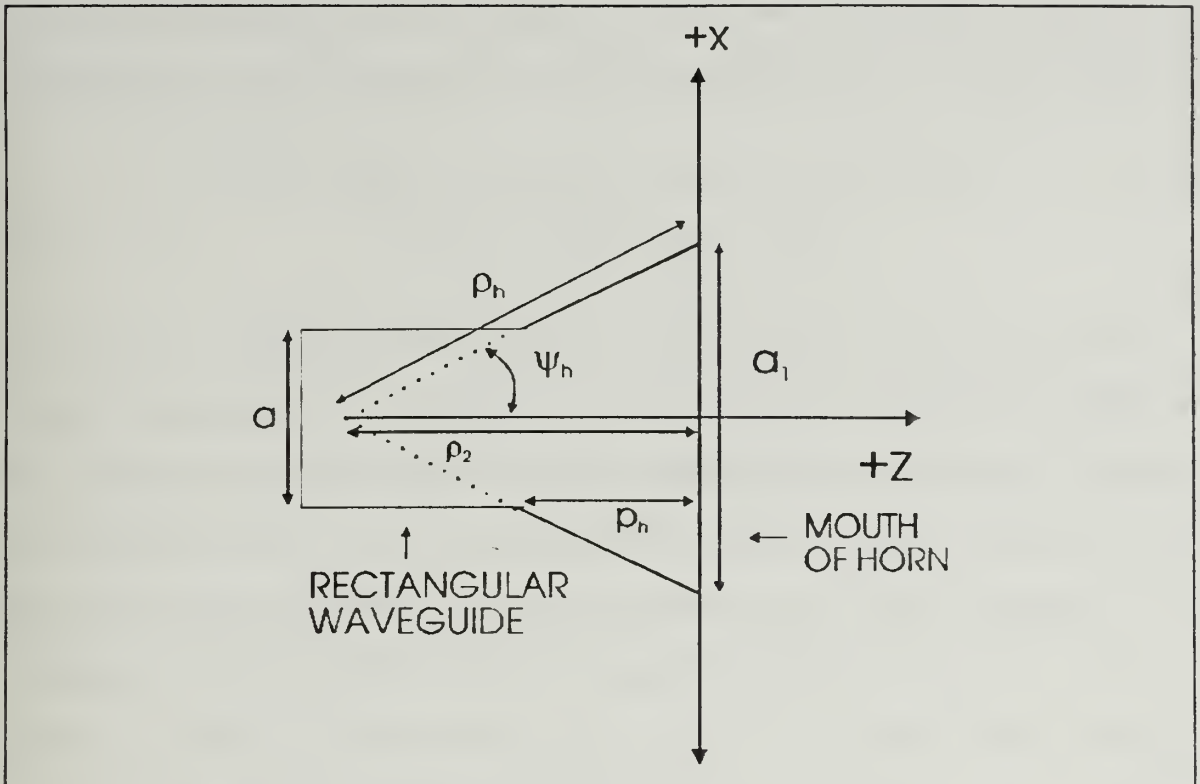

FIGURE 9.2 H-Plane Pyramidal Horn Geometry

In Figures 9.1 and 9.2, (a) and (b) are the dimensions of the rectangular waveguide used to excite the horn, ( $a_1$ ) and ( $b_1$ ) are the dimensions of the mouth of the horn, ( $\psi_{e,h}$ ) are half the flare angles in the indicated planes, ( $\rho_{1,2,e,h}$ ) are the distances from the imaginary apex of horn to the indicated points on the perimeter of the mouth of the horn, and ( $p_{e,h}$ ) are the distances from the beginning of the horn's flare to the center of the mouth of the horn along the indicated axis.

To physically construct a pyramidal horn, the parameters ( $p_e$ ) and ( $p_h$ ) should be equal. These dimensions are calculated as follows [Ref 3: p. 568]:

$$p_e = (b_1 - b) \sqrt{\left(\frac{p_e}{b_1}\right)^2 - \frac{1}{4}} \quad (m) \quad (9.1)$$

$$p_h = (a_1 - a) \sqrt{\left(\frac{p_h}{a_1}\right)^2 - \frac{1}{4}} \quad (m) \quad (9.2)$$

The Mathcad pyramidal horn applications do not calculate a bandwidth of operating frequencies. Rather, the applications compute a matrix of transverse electric (TE) and transverse magnetic (TM) cutoff frequencies ( $f_c$ ) based on the dimension of the waveguide. The cutoff frequencies are the lowest frequencies of a given mode which can propagate in the waveguide. Cutoff frequency for transverse electric or transverse magnetic wave of mode (m,n) in an air filled waveguide is given by [Ref 4: p. 549]:

$$(f_c)_{m,n} = \frac{1}{2\sqrt{\mu_o \epsilon_o}} \sqrt{\left(\frac{m}{a}\right)^2 + \left(\frac{n}{b}\right)^2} \quad (Hz) \quad (9.3)$$

In (9.3), ( $\mu_o$ ) is the permeability of free space, ( $\epsilon_o$ ) is the permittivity of free space, and (m) and (n) are integers. For transverse magnetic waves, (m) and (n) must be non-zero. For transverse electric waves, either (m) or (n) may be zero, but not both. The mode with the lowest cutoff frequency is called the dominant mode. The (TE<sub>10</sub>) mode is dominant in a rectangular waveguide.

Assuming the electric fields behind the mouth of the horn are zero and the physical dimensions of the horn are negligible



in the far-field, one may express the electric field components of a pyramidal horn in the +z half-plane as [Ref 3: pp. 565-578]:

$$E_{\theta} = jkE_o \frac{e^{-jkr}}{4\pi r} [\sin(\phi) (1 + \cos(\theta)) I_1 I_2] \quad (V/m) \quad (9.4)$$

$$E_{\phi} = jkE_o \frac{e^{-jkr}}{4\pi r} [\cos(\phi) (1 + \cos(\theta)) I_1 I_2] \quad (V/m) \quad (9.5)$$

In (9.4) and (9.5), ( $E_o$ ) is an electric field amplitude scale factor set to unity by the Mathcad applications, ( $r$ ) is the distance from the origin to an observation point in the far-field and ( $k$ ) is the wavenumber corresponding to the wavelength ( $\lambda$ ) of a frequency ( $f$ ) of interest and is given by:

$$k = \frac{2\pi}{\lambda} \quad (m^{-1}) \quad (9.6)$$

The functions ( $I_1$ ) and ( $I_2$ ) in (9.4) and (9.5) are computed by:

$$I_1 = \int_{-\frac{a_1}{2}}^{\frac{a_1}{2}} \cos\left(\frac{\pi}{a} \xi\right) e^{-jk\left[\frac{\xi^2}{2\rho_2} - \xi \sin(\theta) \cos(\phi)\right]} d\xi \quad (\text{dimensionless}) \quad (9.7)$$

$$I_2 = \int_{-\frac{b_1}{2}}^{\frac{b_1}{2}} e^{-jk\left[\frac{\xi^2}{2\rho_1} - \xi \sin(\theta) \sin(\phi)\right]} d\xi \quad (\text{dimensionless}) \quad (9.8)$$

The Mathcad application user should note that closed form solutions of (9.4) and (9.5) exist but are very complex and tedious. Thus, the applications use a numerical approximation of these integrals to compute electric field components for the horn.

The electric field components of (9.4) and (9.5) are applicable only in the far-field of the horn. Therefore, the



distance to the far-field observation point must satisfy all of the following [Ref 3: p.92]:

$$r \geq 1.6\lambda \quad (m) \quad (9.9)$$

$$r \geq 5D \quad (m) \quad (9.10)$$

$$r \geq \frac{2D^2}{\lambda} \quad (m) \quad (9.11)$$

In (9.10) and (9.11), (D) is the distance between opposite corners of the mouth of the horn.

The radiation intensity (U), radiated power ( $P_{rad}$ ), directivity ( $D_o$ ), and effective isotropic radiated power (EIRP) of a pyramidal horn are calculated using generic antenna equations as follows:

$$U = \frac{r^2}{2\eta_o} [ |E_\theta|^2 + |E_\phi|^2 ] \quad (W/solid \text{ ang}) \quad (9.12)$$

$$P_{rad} = \iint_{\Omega} U \sin(\theta) d\theta d\phi \quad (W) \quad (9.13)$$

$$D_o = \frac{4\pi U_{max}}{P_{rad}} \quad (\text{dimensionless}) \quad (9.14)$$

$$EIRP = P_{rad} D_o \quad (W) \quad (9.15)$$

In (9.12), ( $\eta_o$ ) is the intrinsic impedance of free space, in (9.13), ( $\Omega$ ) is the hemisphere of radius (r) in the +z half-space, and in (9.14), ( $U_{max}$ ) is the maximum radiation intensity anywhere on that hemisphere.

The efficiency of a pyramidal horn is difficult to predict

based on measured geometry alone. However, the typical horn can reasonably be assumed to be approximately 50% efficient. Thus, Mathcad pyramidal horn applications compute gain as follows:

$$G = .5D_o \quad (\text{dimensionless}) \quad (9.16)$$

The unit polarization vector ( $\sigma_a$ ) of a pyramidal horn's electromagnetic wave at a point in the far-field is determined using the electric field components from (9.4) and (9.5). The antenna's unit polarization vector in Cartesian coordinates is computed by [Ref 4: pp. 34, 364-367]:

$$E_x = E_\theta \cos(\theta) \cos(\phi) - E_\phi \sin(\phi) \quad (V/m) \quad (9.17)$$

$$E_y = E_\theta \cos(\theta) \sin(\phi) + E_\phi \cos(\phi) \quad (V/m) \quad (9.18)$$

$$E_z = -E_\theta \sin(\theta) \quad (V/m) \quad (9.19)$$

$$\bar{\sigma}_a(x, y, z) = \frac{\bar{a}_x E_x + \bar{a}_y E_y + \bar{a}_z E_z}{\sqrt{|E(x, y, z)|}} \quad (\text{dimensionless}) \quad (9.20)$$

If an incoming wave's unit polarization vector ( $\sigma_w$ ) is known or can be estimated, the pyramidal horn's polarization loss factor (PLF) can be determined by [Ref 3: p. 51]:

$$PLF = |\bar{\sigma}_w \cdot \bar{\sigma}_a^*|^2 \quad (\text{dimensionless}) \quad (9.21)$$

The maximum effective aperture ( $A_{em}$ ) and aperture efficiency ( $\epsilon_{ap}$ ) of the pyramidal horn is written as [Ref 3: p.63]:

$$A_{em} = .5D_o (PLF) \left( \frac{\lambda^2}{4\pi} \right) \quad (m^2) \quad (9.22)$$

$$\epsilon_{ap} = \frac{A_{em}}{a_1 b_1} \quad (\text{dimensionless}) \quad (9.23)$$

The amplitude of the input current ( $I_o$ ) used to excite the rectangular waveguide cannot be calculated based on dimensional information alone. Thus, in order to compute radiation resistance ( $R_r$ ) and maximum effective height ( $h_{em}$ ), a normalized value of 1 amp is assumed to excite the waveguide. These parameters are expressed as [Ref 2: p. 42]:

$$R_r = \frac{2P_{rad}}{|I_o|^2} \quad (\Omega) \quad (9.24)$$

$$h_{em} = 2 \sqrt{\frac{R_r A_{em}}{\eta_o}} \quad (m) \quad (9.25)$$

The Mathcad pyramidal horn applications may also be used to analyze E-plane and H-plane sectoral horns. The term  $(\xi^2/2\rho)$  in the exponents of the integrals of (9.7) and (9.8) is a phase error term that accounts for differences in phase between the center and any point in the aperture of the horn. The sectoral horns are evaluated by eliminating the phase error term in the direction that is not flared. To accomplish this modification to (9.7) and (9.8), the application user is directed to set (a1) equal to (a) for E-plane sectoral horn analysis and (b1) equal to (b) for H-plane sectoral horn analysis. If the application user makes these selections, ( $I_1$ ) for the E-plane sectoral horn or ( $I_2$ ) for the H-plane sectoral horn is altered, respectively, as

follows [Ref 3: pp. 536, 552]:

$$I_1 = -\left(\frac{\pi a}{2}\right) \left[ \frac{\cos\left(\frac{ka}{2} \sin(\theta) \cos(\phi)\right)}{\left(\left(\frac{ka}{2} \sin(\theta) \cos(\phi)\right)^2 - \left(\frac{\pi}{2}\right)^2\right)} \right] \quad (9.26)$$

(dimensionless)

$$I_2 = \left[ \frac{\sin\left(\frac{kb}{2} \sin(\theta) \sin(\phi)\right)}{\frac{kb}{2} \sin(\theta) \sin(\phi)} \right] \quad (dimensionless) \quad (9.27)$$

Table 9.1, Figure 9.3, and Figure 9.4 compare measured data to that calculated by the Mathcad applications for a pyramidal horn ( $\rho_1=.3398$  meters  $\rho_2=.3198$  meters,  $a_1=.1846$  meters,  $b_1=.1455$  meters,  $a=.02286$  meters,  $b=.01016$  meters) operating at 9.3 GHz [Ref 5: pp. 413-415].

TABLE 9.1 Pyramidal Horn Data Comparison

ANTENNA PARAMETER	MEASURED DATA	CALCULATED DATA
DIRECTIVITY	21.3 dB	21.6 dB

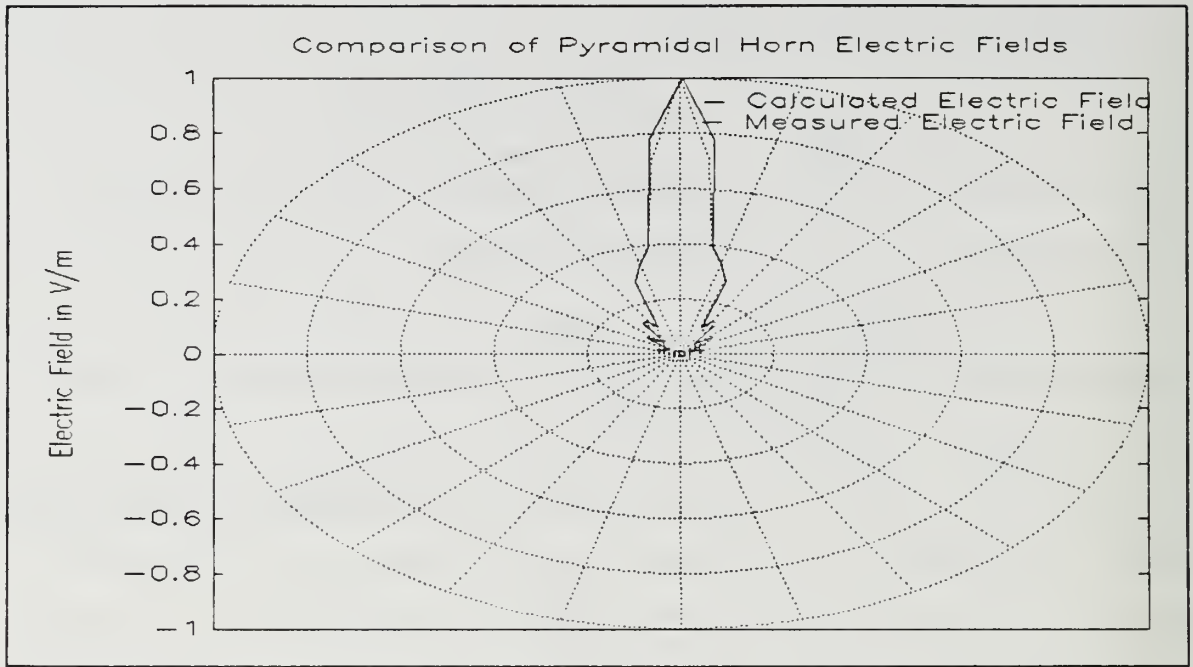

FIGURE 9.3 E-Plane Pyramidal Horn Electric Field Pattern

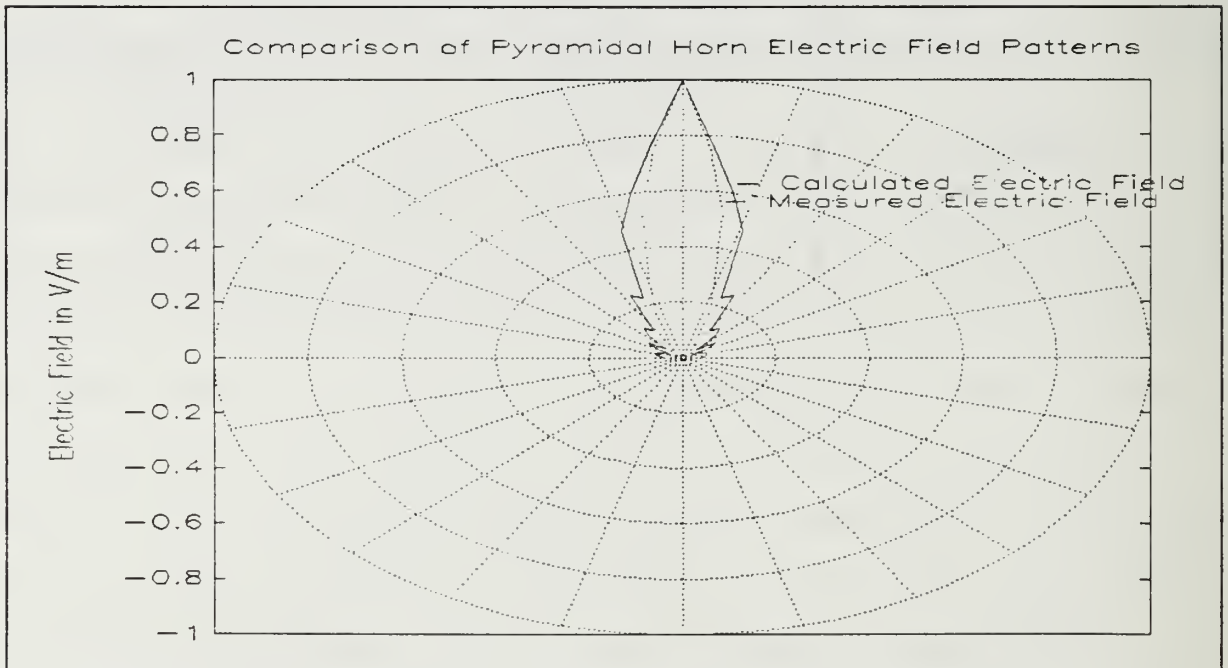

FIGURE 9.4 H-Plane Pyramidal Horn Electric Field Pattern

## X. REMARKS AND CONCLUSIONS

The intent of this thesis and associated software was to provide the Naval Maritime Intelligence Center (NAVMARINTCEN) with a relatively simple, user friendly set of Mathcad applications that would analyze various types of antennas based solely on dimensional information and ground characteristics. Although the software format achieves the goal of easy use, the nature of the formulas applicable to many of the antennas necessarily reduces the simplicity of the programs. Indeed, many of the equations used in this research project are so complex that they are not found in any existing textbook dealing with antennas. Nevertheless, the Mathcad applications developed in conjunction with this thesis **allow the user to analyze several antennas that cannot be studied with current electromagnetics software packages** such as ELNEC, NEC, or WIRE. And, in every case, the Mathcad applications compute antenna parameters and far-field radiation patterns that closely compare with measured or predicted results.

The Mathcad applications are compatible with any personal computer that supports Mathcad 3.1 for Windows. However, many of the programs require a numerical solution of highly complicated integral equations that are computationally intensive. Where necessary to reduce processing time, the applications use trapezoidal approximations as an alternative numerical procedure to evaluate required integrals. Nevertheless, several programs still require several days to complete calculations on a 33 MHz,



386 personal computer.

As previously mentioned, several of the antennas included in this project are not adequately reviewed by current texts. Thus, equations from many professional journals and doctoral dissertations are used for a number of the applications. Unfortunately, many errors existed in these sources, and resolution of these mistakes significantly slowed the progress of our research.

The most disappointing aspect of the Mathcad application software aside from the excessive length of time required to analyze some types of antennas is the graphical presentation of the far-field radiation patterns. Mathcad's limited graphics flexibility, particularly in regards to three-dimensional and spherical coordinate plots, precluded better presentation of output data.

The equations and data of this antenna analysis package could easily be transferred to another mathematics program, such as MATLAB. Although a MATLAB program may not be as easy for a new user to employ, it might offer advantages with respect to lower processing time and improved graphical output.

When built to the proper specifications, the helical antenna possesses many qualities which make it suitable for a wide variety of communications applications. If the following conditions are satisfied the helix will exhibit a highly directional axial main lobe, low side lobe level, negligible mutual interference with adjacent antennas, low voltage standing wave ratio (VSWR), and resistive input impedance over a wide frequency band:

$$\begin{aligned} .8 &\leq C_\lambda \leq 1.15 \\ n &> 3 \\ 12 &\leq \alpha \leq 14 \end{aligned}$$

(Note:  $\lambda$  in a subscript indicates the dimension is in wavelengths. Mathcad equations can not use symbolic subscripts. Therefore, the symbol  $\lambda$  will immediately follow the parameter in equations (i.e.,  $C_\lambda$ )).

The helical antenna Mathcad application will compute the following parameters (Items with \* indicate parameters that are calculated for both axial and peripheral feed geometries):

C = circumference of helix  
 $\lambda$  = wavelength  
 $\alpha$  = pitch angle  
 $D_o$  = directivity  
p = relative phase velocity  
 $E_{\theta,\phi}$  = Electric Field Components  
 $\Psi$  = Array Factor Phase Shift  
U = Radiation Intensity  
 $P_{rad}$  = Radiated Power  
R = Antenna Input Resistance\*  
 $\Gamma$  = Voltage Reflection Coefficient\*  
 $\epsilon_r$  = Reflection Efficiency\*  
 $h_{em}$  = Maximum Effective Height\*  
G = Gain\*  
EIRP = Effective Isotropic Radiated Power  
 $A_{em}$  = Maximum Effective Aperture\*  
AR = Axial Ratio  
PLF = Polarization Loss Factor  
BW = Bandwidth  
 $f_{high}$  = Upper Frequency Limit  
 $f_{low}$  = Lower Frequency Limit  
Acceptable Conductor Diameter  
 $E_x, y, z$  = Electric Field Cartesian Components  
 $\theta_p, \phi_p$  = Unit Polarization Vector Coordinate Angles  
 $\sigma_a$  = Antenna Unit Polarization Vector  
 $r_{min}$  = Minimum Distance to the Far-Field



Calculate helical geometric parameters and define constants:

$$c := 2.9979 \cdot 10^8 \quad (\text{meters / sec})$$

$$\eta_0 := 120 \cdot \pi \quad (\Omega)$$

$$C = \pi \cdot D \quad (\text{meters})$$

$$\lambda := \frac{c}{f} \quad (\text{meters / cycle})$$

$$C = 0.33741 \quad (\text{meters})$$

$$\lambda = 0.3241 \quad (\text{meters / cycle})$$

$$C\lambda := \frac{C}{\lambda} \quad (\text{dimensionless})$$

$$S\lambda := \frac{S}{\lambda} \quad (\text{dimensionless})$$

$$C\lambda = 1.04107 \quad (\text{dimensionless})$$

$$S\lambda = 0.23635 \quad (\text{dimensionless})$$

$$\alpha := \text{atan}\left\{\frac{S}{C}\right\} \quad (\text{radians})$$

$$L\lambda = \frac{L}{\lambda} \quad (\text{dimensionless})$$

$$\alpha = 0.22324 \quad (\text{radians})$$

$$L\lambda = 2.36349 \quad (\text{dimensionless})$$

$$\alpha_d = \frac{180}{\pi} \cdot \alpha \quad (\text{degrees})$$

$$\alpha_d = 12.7908 \quad (\text{degrees})$$

Calculate helical antenna parameters:

Define angular offset  $\theta$   
from helical axis:

Minimum Distance to the Far-Field  
 $r_{\min}$ :

$$\theta = 0, \frac{2 \cdot \pi}{i} \dots 2 \cdot \pi \quad (\text{radians})$$

$$r_0 = 1.6 \cdot \lambda \quad (\text{meters})$$

$$\phi := 0, \left\{ \frac{\pi}{11} \right\} \dots 2 \cdot \pi \quad (\text{radians})$$

$$r_1 := 5 \cdot n \cdot S \quad (\text{meters})$$

$$r_2 = \frac{2 \cdot (n \cdot S)^2}{\lambda} \quad (\text{meters})$$

$$r_{\min} := \max(r) \quad (\text{meters})$$

$$r_{\min} = 3.83 \quad (\text{meters})$$

Relative Phase Velocity p:

$$p := \frac{L\lambda}{S\lambda + m + \left\{ \frac{1}{2 \cdot n} \right\}} \quad (\text{dimensionless})$$

$$p = 1.83736 \quad (\text{dimensionless})$$

Array Factor Phase Shift  $\psi$ :

$$\psi(\theta) = 2 \cdot \pi \left\{ S\lambda \cdot \cos(\theta) - \frac{L\lambda}{p} \right\} \quad (\text{radians})$$

Electric Field Field Components  $E_\theta, E_\phi$ :

$$E(\theta) := \left| \frac{\sin\left\{ \frac{\pi}{2 \cdot n} \right\} \cdot \sin\left\{ \frac{n \psi(\theta)}{2} \right\}}{\sin\left\{ \frac{\psi(\theta)}{2} \right\}} \cdot \cos(\theta) \right| \quad (\text{V / m})$$

$$E_\theta(\theta) := E(\theta) \quad (\text{V / m})$$

$$E_\phi(\theta) := j \cdot E(\theta) \quad (\text{V / m})$$

Radiation Intensity  $U(\theta)$ :

$$U(\theta) := \frac{1}{\eta_0} (|E(\theta)|)^2 \quad (\text{W / solid angle})$$

Radiated Power  $P_{\text{rad}}$ :

$$P_{\text{rad}} := \int_0^{2\pi} \int_0^{\pi} U(\theta) \cdot \sin(\theta) \, d\theta \, d\phi \quad (\text{W})$$

$$P_{\text{rad}} = 1.2394 \cdot 10^{-3} \quad (\text{W})$$

Directivity  $D_0$ :

$$D_0 := 12 \cdot C_A^2 \cdot n \cdot S_A \quad (\text{dimensionless}) \qquad D_{02} := \frac{4 \pi U(0)}{P_{\text{rad}}} \quad (\text{dimensionless})$$

$$D_0 = 30.73917 \quad (\text{dimensionless}) \qquad D_{02} = 26.89463 \quad (\text{dimensionless})$$

Axial Ratio AR:

$$AR := \left| \text{Li} \cdot \left\{ \sin(\alpha) - \frac{1}{P_A} \right\} \right| \quad (\text{dimensionless})$$

$$AR = 0.76309 \quad (\text{dimensionless})$$

Effective Isotropic Radiated Power EIRP:

$$EIRP := P_{\text{rad}} \cdot D_0 \quad (\text{W}) \qquad EIRP2 := P_{\text{rad}} \cdot D_{02} \quad (\text{W})$$

$$EIRP = 0.0381 \quad (\text{W}) \qquad EIRP2 = 0.03333 \quad (\text{W})$$



Polarization Loss Factor PLF:

$$\theta_p = \operatorname{atan}\left(\frac{\sqrt{x^2 + y^2}}{z}\right) \quad (\text{radians})$$

$$\phi_p = \operatorname{atan}\left(\frac{y}{x}\right) \quad (\text{radians})$$

$$\theta_p = 1.41421 \cdot 10^{-3} \quad (\text{radians})$$

$$\phi_p = 0.7854 \quad (\text{radians})$$

$$E_x := E\theta(\theta_p) \cdot \cos(\theta_p) \cos(\phi_p) - E\phi(\theta_p) \cdot \sin(\phi_p) \quad (\text{V/m})$$

$$E_y := E\theta(\theta_p) \cdot \cos(\theta_p) \sin(\phi_p) + E\phi(\theta_p) \cdot \cos(\phi_p) \quad (\text{V/m})$$

$$E_z := E\theta(\theta_p) \cdot \sin(\theta_p) \cdot 1 \quad (\text{V/m})$$

$$\sigma_a := \frac{1}{\sqrt{(|E_x|)^2 + (|E_y|)^2 + (|E_z|)^2}} \begin{Bmatrix} E_x \\ E_y \\ E_z \end{Bmatrix} \quad (\text{dimensionless})$$

$$\sigma_a = \begin{bmatrix} 0.5 - 0.5j \\ 0.5 + 0.5j \\ -9.99999 \cdot 10^{-4} \end{bmatrix} \quad (\text{dimensionless})$$

$$\text{PLF} := \left( \left| \sigma_w \cdot \sigma_a \right| \right)^2 \quad (\text{dimensionless})$$

$$\text{PLF} = 1 \quad (\text{dimensionless})$$

Radiation Resistance  $R_r$ :

$$R_r := 2 \cdot \frac{\text{Prad}}{(|I_0|)^2} \quad (\Omega)$$

$$R_r = 2.47881 \cdot 10^{-3} \quad (\Omega)$$

Dual Parameters

Axial Feed

Peripheral Feed

Input Resistance R:

$$R_a := 140 \cdot \sqrt{C_i} \quad (\Omega)$$

$$R_p := \frac{150}{\sqrt{C_i}} \quad (\Omega)$$

$$R_a = 1.42846 \cdot 10^2 \quad (\Omega)$$

$$R_p = 1.47012 \cdot 10^2 \quad (\Omega)$$

Voltage Reflection Coefficient  $\Gamma$ :

$$\Gamma_a := \frac{R_a - Z_0}{R_a + Z_0} \quad (\text{dimensionless})$$

$$\Gamma_p := \frac{R_p - Z_0}{R_p + Z_0} \quad (\text{dimensionless})$$

$$\Gamma_a = -0.02443 \quad (\text{dimensionless})$$

$$\Gamma_p = -0.01006 \quad (\text{dimensionless})$$

Reflection Efficiency  $\epsilon_r$ :

$$\epsilon_{ra} := 1 - (|\Gamma_a|)^2 \quad (\text{dimensionless})$$

$$\epsilon_{rp} := 1 - (|\Gamma_p|)^2 \quad (\text{dimensionless})$$

$$\epsilon_{ra} = 0.9994 \quad (\text{dimensionless})$$

$$\epsilon_{rp} = 0.9999 \quad (\text{dimensionless})$$

Gain G:

$$G_a := \epsilon_a D_o \quad (\text{dimensionless}) \quad G_p := \epsilon_p D_o \quad (\text{dimensionless})$$

$$G_{adb} := 10 \log(\epsilon_a D_o) \quad (\text{dB}) \quad G_{pdb} := 10 \log(\epsilon_p D_o) \quad (\text{dB})$$

$$G_a = 30.72082 \quad (\text{dimensionless}) \quad G_p = 30.73606 \quad (\text{dimensionless})$$

$$G_{adb} = 14.87433 \quad (\text{dB}) \quad G_{pdb} = 14.87648 \quad (\text{dB})$$

$$G_{a2} := \epsilon_a \cdot D_{o2} \quad (\text{dimensionless}) \quad G_{p2} := \epsilon_p \cdot D_{o2} \quad (\text{dimensionless})$$

$$G_{adb2} := 10 \log(\epsilon_a D_{o2}) \quad (\text{dB}) \quad G_{pdb2} := 10 \log(\epsilon_p D_{o2}) \quad (\text{dB})$$

$$G_{a2} = 26.87858 \quad (\text{dimensionless}) \quad G_{p2} = 26.89191 \quad (\text{dimensionless})$$

$$G_{adb2} = 14.29406 \quad (\text{dB}) \quad G_{pdb2} = 14.29622 \quad (\text{dB})$$

Maximum Effective Aperture  $A_{em}$ :

$$A_{ema} := \frac{\epsilon_a \lambda^2 \cdot D_o}{4 \pi} \cdot \text{PLF} \quad (\text{m}^2) \quad A_{emp} := \frac{\epsilon_p \lambda^2 \cdot D_o}{4 \pi} \cdot \text{PLF} \quad (\text{m}^2)$$

$$A_{ema} = 0.25679 \quad (\text{m}^2) \quad A_{emp} = 0.25691 \quad (\text{m}^2)$$

$$A_{ema2} := \frac{\epsilon_a \lambda^2 \cdot D_{o2}}{4 \pi} \cdot \text{PLF} \quad (\text{m}^2) \quad A_{emp2} := \frac{\epsilon_p \lambda^2 \cdot D_{o2}}{4 \pi} \cdot \text{PLF} \quad (\text{m}^2)$$

$$A_{ema2} = 0.22467 \quad (\text{m}^2) \quad A_{emp2} = 0.22478 \quad (\text{m}^2)$$

Maximum Effective Height  $h_{emi}$ :

$$hema = 2 \cdot \sqrt{\text{Rr} \frac{Aema}{\eta_0}} \quad (\text{m})$$

$$hemp = 2 \cdot \sqrt{\text{Rr} \frac{Aemp}{\eta_0}} \quad (\text{m})$$

$$hema = 2.5988 \cdot 10^{-3} \quad (\text{m})$$

$$hemp = 2.59944 \cdot 10^{-3} \quad (\text{m})$$

$$hema2 = 2 \cdot \sqrt{\text{Rr} \frac{Aema2}{\eta_0}} \quad (\text{m})$$

$$hemp2 = 2 \cdot \sqrt{\text{Rr} \frac{Aemp2}{\eta_0}} \quad (\text{m})$$

$$hema2 = 2.43086 \cdot 10^{-3} \quad (\text{m})$$

$$hemp2 = 2.43146 \cdot 10^{-3} \quad (\text{m})$$

Bandwidth:

$$f_{high} := \frac{1.15 \cdot c}{C} \quad (\text{Hz})$$

$$f_{low} := \frac{.8 \cdot c}{C} \quad (\text{Hz})$$

$$f_{high} = 1.02179 \cdot 10^9 \quad (\text{Hz})$$

$$f_{low} = 7.10809 \cdot 10^8 \quad (\text{Hz})$$

$$BW = f_{high} - f_{low} \quad (\text{Hz})$$

$$BW = 3.10979 \cdot 10^8 \quad (\text{Hz})$$

Acceptable Conductor Diameter:

$$d_{min} := .005 \cdot \lambda \quad (\text{m})$$

$$d_{max} := .05 \cdot \lambda \quad (\text{m})$$

$$d_{min} = 1.62049 \cdot 10^{-3} \quad (\text{m})$$

$$d_{max} = 0.0162 \quad (\text{m})$$

HELICAL ANTENNA FAR-FIELD RADIATION PATTERN

For the purpose of this far-field radiation pattern, the helical antenna axis is equivalent to the  $E_x = 0$  grid line. The pattern is essentially symmetric when rotated about the antenna's axis.

$$E_x(\theta) := E\left\{\theta - \frac{\pi}{2}\right\} \cdot \cos(\theta) \qquad E_y(\theta) := E\left\{\theta - \frac{\pi}{2}\right\} \cdot \sin(\theta)$$

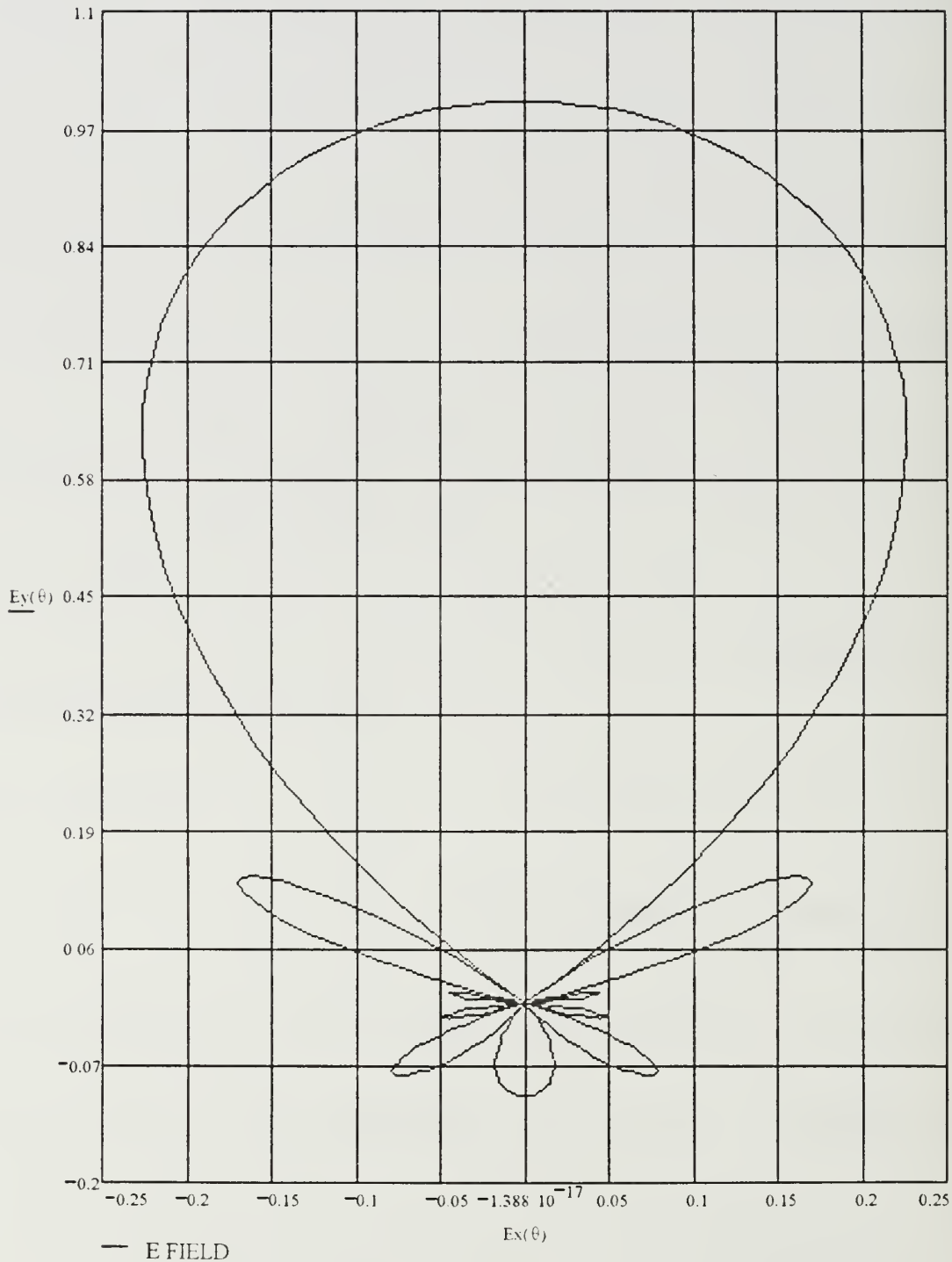

THE BEVERAGE ANTENNA  
MATHCAD SOFTWARE-BEVERAGE.MCD

The Beverage antenna is a single wire structure parallel to the ground. It is terminated with a load matching the characteristic impedance of the wire. Because there is little or no reflected energy from the antenna's termination, the Beverage antenna does not develop a significant standing wave. Therefore, it is known as a traveling wave antenna. The Beverage antenna is also known as a slow wave antenna since the relative phase velocity along the wire is usually less than one.

The Beverage antenna is used for a wide range of frequencies, depending on its length and the characteristics of the ground under the antenna. It transmits and receives vertically polarized electromagnetic waves primarily through a cone shaped main beam pointing in the direction of the traveling wave. In the far-field, the electric field pattern above the ground can be considered rotationally symmetric with respect to the axis of the antenna.

A Beverage antenna exhibits a highly directional main lobe and resistive input impedance for frequencies corresponding to the following lengths:

$$.5 \leq L_j \leq 2.0 \quad (\text{wavelengths})$$

(Note:  $\lambda$  in a subscript indicates the dimension is in wavelengths. Mathcad equations can not use symbolic subscripts. Therefore, the symbol  $\lambda$  will immediately follow the parameter in equations (i.e.,  $L_j$ ) to indicate the dimension is in wavelengths.)

The Beverage antenna Mathcad application will compute the following parameters:

$L_j$  = Length of Antenna in Wavelengths  
 $\lambda$  = Wavelength  
 $D_0$  = Directivity  
 $p$  = Relative Phase Velocity  
 $E$  = Electric Field (No Ground Effects)  
 $E_t$  = Electric Field (Total Field Including Ground Effects)  
 $U$  = Radiation Intensity  
 $P_{rad}$  = Radiated Power  
 $Z_0$  = Antenna Characteristic Impedance  
 $\Gamma$  = Voltage Reflection Coefficient  
 $\Gamma_v$  = Vertical Reflection Coefficient (Ground Reflection)  
 $\epsilon_{rv}$  = Reflection Efficiency  
 $G$  = Gain  
 $EIRP$  = Effective Isotropic Radiated Power  
 $A_{em}$  = Maximum Effective Aperture  
 $PLF$  = Polarization Loss Factor  
 $\theta_{max}$  = Angle of Maximum Radiation  
 $BW$  = Bandwidth  
 $f_{high}$  = Upper Frequency Limit  
 $f_{low}$  = Lower Frequency Limit  
Acceptable Conductor Diameter

$\epsilon_r$  = Ground Relative Complex Permittivity

(Note: The subscript ' will be annotated as p in the application)

$d_{max}$  = Maximum Acceptable Conductor Diameter

$r_{min}$  = Minimum Distance to Far-Field

$R_r$  = Radiation Resistance

X = Electric Field Function

The following data must be input based on known or estimated data:

h = Height of Antenna above ground

L = Length of Antenna

d = Diameter of Conductor

f = Frequency of Interest

i = Number of Increments in Degrees for Far Field Radiation Pattern

$Z_l$  = Load Impedance

$\sigma_w$  = Incident Wave Electric Field Unit Vector

$\theta_a$  = Incident Wave Arrival Angle

$\sigma$  = Ground Conductivity

$\epsilon_r$  = Ground Relative Permittivity

$r_{ff}$  = Distance of Field Calculations

$I_0$  = Input Current at Antenna Terminals

---

Enter input data here:

$\sigma_w := \begin{Bmatrix} 1 \\ 0 \\ 0 \end{Bmatrix}$  (dimensionless)       $\sigma := .01$  (mhos / m)

$d := .005$  (meters)       $\epsilon_r := 2$  (dimensionless)

$i := 360$  (degrees)       $r_{ff} := 1000$  (meters)

$h := .1$  (meters)       $I_0 := 1$  (amps)

$Z_l := 150$  ( $\Omega$ )       $L := 200$  (meters)

$\theta_a := \frac{\pi}{180} 20$  (radians)       $f := 1.6 \cdot 10^6$  (Hz)

---



Calculate Beverage antenna geometric parameters and define constants:

$$c := 2.9979 \cdot 10^8 \quad (\text{meters / sec})$$

$$\lambda := \frac{c}{f} \quad (\text{meters / cycle})$$

$$\lambda = 1.87369 \cdot 10^2 \quad (\text{meters / cycle})$$

$$L\lambda := \frac{L}{\lambda} \quad (\text{dimensionless})$$

$$L\lambda = 1.06741 \quad (\text{dimensionless})$$

$$\sigma_a := \begin{Bmatrix} 1 \\ 0 \\ 0 \end{Bmatrix} \quad (\text{dimensionless})$$

$$\eta_0 := 120 \pi \quad (\Omega)$$

$$\epsilon_0 := \frac{1}{36 \cdot \pi} \cdot 10^{-9} \quad (\text{Farads / m})$$

Calculate Beverage antenna parameters:

Define angular offset  $\theta$   
from Beverage antenna axis:

$$\theta := 0, \frac{\pi}{i}, \pi \quad (\text{radians})$$

$$\phi := 0, \begin{Bmatrix} \pi \\ 1 \end{Bmatrix} \dots \pi \quad (\text{radians})$$

Minimum Distance to Far-Field  
 $r_{min}$ :

$$r_0 := 1.6 \cdot \lambda \quad (\text{m})$$

$$r_1 = 5 \cdot L \quad (\text{m})$$

$$r_2 := \frac{2 \cdot L^2}{\lambda} \quad (\text{m})$$

$$r_{min} = \max(r) \quad (\text{m})$$

$$r_{min} = 1 \cdot 10^3 \quad (\text{m})$$

Relative Phase Velocity p:

$$p := .65891 \cdot \left\{ \frac{f}{1000} \right\}^{.038523821} \quad (\text{dimensionless})$$

$$p = 0.87551 \quad (\text{dimensionless})$$

Maximum length  $L_{\max}$ :

$$L_{\max} := \frac{1}{4 \left\{ \frac{1}{p} - \cos(\theta a) \right\}} \quad (\text{wavelengths})$$

$$L_{\max} = 1.2345 \quad (\text{wavelengths})$$

Wavenumber  $k$ :

$$k := \frac{2 \cdot \pi}{\lambda} \quad (\text{m}^{-1})$$

$$k = 0.03353 \quad (\text{m}^{-1})$$

Electric Field Function  $X$ :

$$X(\theta) := \frac{kL}{2} (1 - \cos(\theta)) \quad (\text{radians})$$

Electric Field Without Ground Effects  $E(\theta)$ :

$$E(\theta) := \frac{30 k L I_0 \sin(\theta)}{r^2} \left| \frac{\sin(X(\theta))}{X(\theta)} \right| \quad (\text{V/m})$$

Relative Complex Dielectric Coefficient  $\epsilon_r$ :

$$\epsilon_r := \epsilon - j \frac{\sigma}{2 \pi f \epsilon_0} \quad (\text{dimensionless})$$

$$\epsilon_r = 2 - 1.125 \cdot 10^2 j \quad (\text{dimensionless})$$

Vertical Reflection Coefficient  $\Gamma_v$ :

$$\Gamma_v(\theta) := \frac{\exp\left\{\cos\left(\frac{\pi}{2} - \theta\right) - \sqrt{\exp - \sin\left(\frac{\pi}{2} - \theta\right)}^2\right\}}{\exp\left\{\cos\left(\frac{\pi}{2} - \theta\right) + \sqrt{\exp - \sin\left(\frac{\pi}{2} - \theta\right)}^2\right\}} \quad (\text{dimensionless})$$

Electric Field With Ground Effects  $E_t(\theta)$ :

$$E_t(\theta) := E(\theta) \cdot \left\{ 1 - \Gamma_v(\theta) \cdot e^{-j \cdot 2 \cdot k \cdot h \cos\left(\frac{\pi}{2} - \theta\right)} \right\} \quad (\text{V/m})$$

Angle of Maximum Radiation  $\theta_{\max}$ :

$$\theta_{\max} := \arccos\left[ 1 - \frac{.371}{\left(\frac{L}{\lambda}\right)} \right] \quad (\text{radians})$$

$$\theta_{\max} = 0.86001 \quad (\text{radians})$$

$$\theta_{\max} \cdot \frac{180}{\pi} = 49.27486 \quad (\text{degrees})$$

Radiation Intensity  $U(\theta)$ :

$$U(\theta) := \frac{r^2}{2 \cdot \eta_0} \cdot (|E(\theta)|)^2 \quad (\text{W / solid angle})$$

$$U_{\max} := U(\theta_{\max}) \quad (\text{W / solid angle})$$

$$U_{\max} = 19.17134 \quad (\text{W / solid angle})$$

Radiated Power  $P_{\text{rad}}$ :

$$P_{\text{rad}} = \int_0^\pi \int_0^\pi U(\theta) \cdot \sin(\theta) \, d\theta \, d\phi \quad (\text{W})$$

$$P_{\text{rad}} = 32.66448 \quad (\text{W})$$

Directivity  $D_0$ :

$$D_0 := \frac{4 \cdot \pi \cdot U_{\text{max}}}{P_{\text{rad}}} \quad (\text{dimensionless})$$

$$D_0 = 7.37542 \quad (\text{dimensionless})$$

Polarization Loss Factor PLF:

$$\text{PLF} = \left\{ \left| \overline{\sigma_w \cdot \sigma_a} \right| \right\}^2 \quad (\text{dimensionless})$$

$$\text{PLF} = 1 \quad (\text{dimensionless})$$

Characteristic Impedance:

$$Z_0 = 138 \log \left\{ \frac{4 \, h}{d} \right\} \quad (\Omega)$$

$$Z_0 = 2.62626 \cdot 10^2 \quad (\Omega)$$

Voltage Reflection Coefficient  $\Gamma$ :

$$\Gamma := \frac{Z_l - Z_0}{Z_l + Z_0} \quad (\text{dimensionless})$$

$$\Gamma = -0.27295 \quad (\text{dimensionless})$$

Reflection Efficiency  $\epsilon_{rv}$ :

$$\epsilon_{rv} := 1 - (|\Gamma|)^2 \quad (\text{dimensionless})$$

$$\epsilon_{rv} = 0.9255 \quad (\text{dimensionless})$$

Effective Isotropic Radiated Power EIRP:

$$\text{EIRP} := \text{Prad} \cdot D_0 \quad (\text{W})$$

$$\text{EIRP} = 2.40914 \cdot 10^2 \quad (\text{W})$$

Gain G:

$$G := \epsilon_{rv} \cdot D_0 \quad (\text{dimensionless})$$

$$G_{db} := 10 \cdot \log\{\epsilon_{rv} \cdot D_0\} \quad (\text{dB})$$

$$G = 6.82594 \quad (\text{dimensionless})$$

$$G_{db} = 8.34162 \quad (\text{dB})$$

Maximum Effective Aperture  $A_{em}$ :

$$A_{em} := \frac{\sigma_v \cdot \lambda^2 \cdot D_0}{4 \cdot \pi} \cdot PLF \quad (m^2)$$

$$A_{em} = 1.90698 \cdot 10^4 \quad (m^2)$$

Radiation Resistance  $R_r$ :

$$R_r := \frac{2 \cdot Prad}{\left( |I_0| \right)^2} \quad (\Omega)$$

$$R_r = 65.32897 \quad (\Omega)$$

Bandwidth:

$$f_{high} := \frac{2 \cdot c}{L\lambda} \quad (Hz)$$

$$f_{high} = 5.61713 \cdot 10^8 \quad (Hz)$$

$$f_{low} := \frac{.5 \cdot c}{L\lambda} \quad (Hz)$$

$$f_{low} = 1.40428 \cdot 10^8 \quad (Hz)$$

$$BW := f_{high} - f_{low} \quad (Hz)$$

$$BW = 4.21285 \cdot 10^8 \quad (Hz)$$

Maximum Effective Height  $h_{em}$ :

$$h_{em} = 2 \cdot \sqrt{\frac{R_r \cdot A_{em}}{\eta_0}} \quad (\text{m})$$

$$h_{em} = 1.14972 \cdot 10^2 \quad (\text{m})$$

Acceptable Conductor Diameter:

$$d_{max} := .01 \cdot L\lambda \quad (\text{m})$$

$$d_{max} = 0.01067 \quad (\text{m})$$



BEVERAGE ANTENNA FAR-FIELD RADIATION PATTERN

For the purpose of this far-field radiation pattern, the Beverage antenna axis is equivalent to the  $E_y = 0$  grid line (Note: Antenna height above ground is negligible in the far-field). The pattern is essentially symmetric when rotated about the antenna's axis above the ground plane.

Electric Field With Ground Effects

$E_x(\theta) = E_t(\theta) \cdot \cos(\theta)$

$E_y(\theta) = E_t(\theta) \cdot \sin(\theta)$

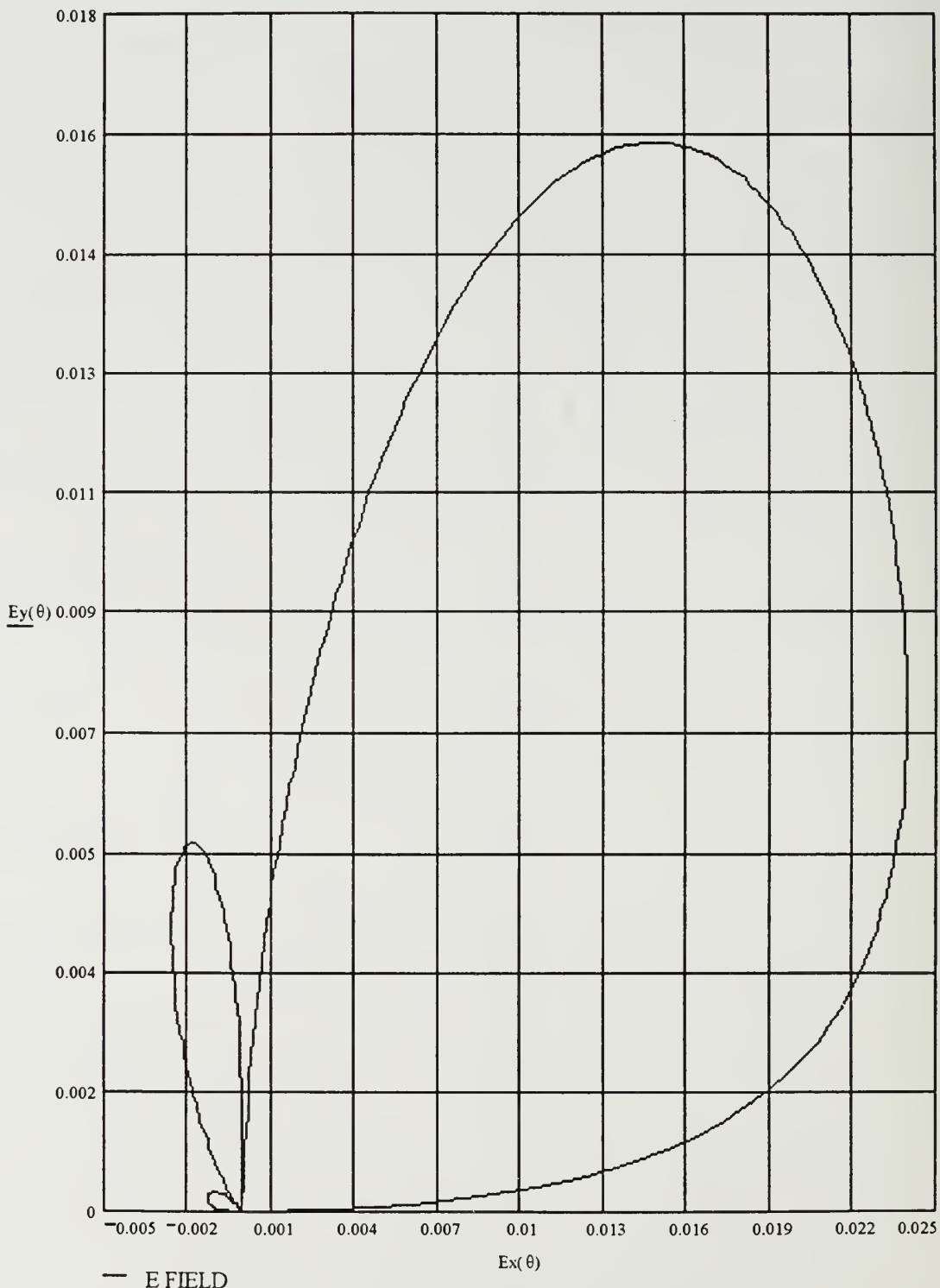

Electric Field Without Ground Effects

$$E_x(\theta) := E(\theta) \cdot \cos(\theta)$$

$$E_y(\theta) := E(\theta) \cdot \sin(\theta)$$

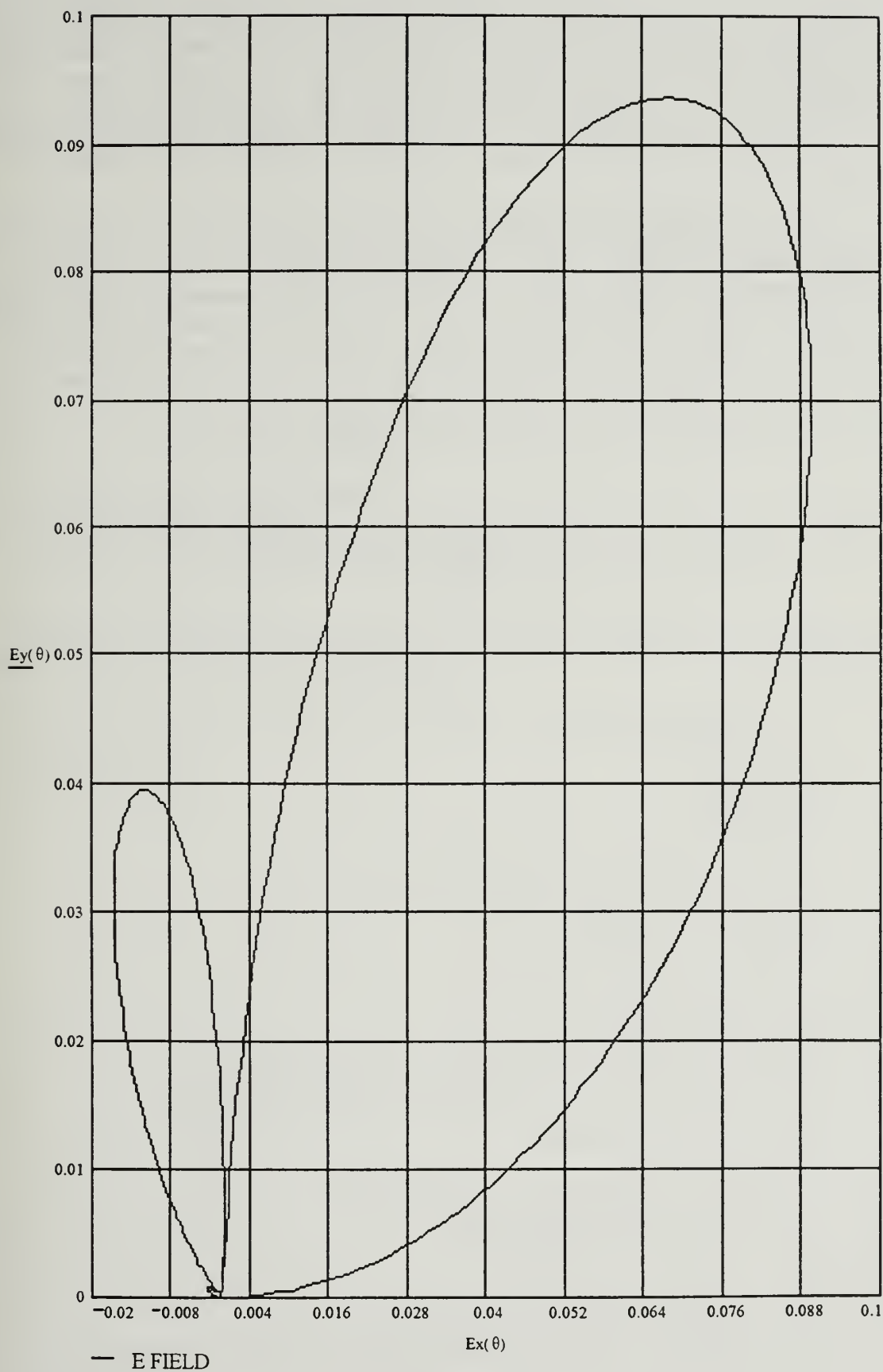

The small loop antenna is a coil of one or more turns whose radius (a) satisfies the following:

$$a \leq \lambda/6\pi \quad (\text{m})$$

where ( $\lambda$ ) is the wavelength of the frequency of interest. Small loops are commonly used to receive signals in the lower frequency regions. They are also used for direction finding and UHF transmissions. The efficiency of a transmitting loop antenna is typically very low. However, antenna efficiency can be improved by inserting a ferrite core in the loop, increasing loop perimeter, or increasing the number of turns.

The small loop Mathcad applications will analyze three geometries: **free space, horizontal loop, and vertical loop**. Each geometry will also examine **air and ferrite cores**. Several antenna parameters, particularly those for loops in free space, can be calculated using more than one formula. Where this occurs, multiple results will be computed for comparison. Computations which are identical for all geometries will not be repeated. Computations with ferrite cores will use effective permeability ( $\mu_e$ ) in lieu of free space permeability ( $\mu_0$ ).

(Note:  $\lambda$  in a subscript indicates the dimension is in wavelengths. Mathcad equations can not use symbolic subscripts. Therefore, the symbol  $\lambda$  will immediately follow the parameter in equations (i.e.,  $L\lambda$ ) to indicate the dimension is in wavelengths.)

The small loop antenna Mathcad application will compute the following parameters:

- S = Cross-Sectional Area
  - C = Circumference
  - k = Wavenumber
  - $\lambda$  = Wavelength
  - $D_0$  = Directivity
  - E = Electric Field (No Ground Effects)
  - $E_t$  = Electric Field (Total Field Including Ground Effects)
  - U = Radiation Intensity
  - $U_{\text{max}}$  = Maximum Radiation Intensity
  - $P_{\text{rad}}$  = Radiated Power
  - $\Gamma$  = Voltage Reflection Coefficient
  - $\Gamma_v$  = Vertical Reflection Coefficient (Ground Reflection)
  - $\Gamma_h$  = Horizontal Reflection Coefficient (Ground Reflection)
  - $\epsilon_{rv}$  = Reflection Efficiency
  - G = Gain
  - EIRP = Effective Isotropic Radiated Power
  - $A_{\text{em}}$  = Maximum Effective Aperture
  - PLF = Polarization Loss Factor
  - Bandwidth
  - $\epsilon_r$  = Ground Relative Complex Permittivity
- (Note: The subscript ' will be annotated as p in the application)

$r_{min}$  = Minimum Distance to Far-Field  
 $R_{ohmic}$  = Ohmic Resistance  
 $R_r$  = Radiation Resistance  
 $R_s$  = Surface Impedance of Conductor  
 $\epsilon_{cd}$  = Conduction-Dielectric Efficiency  
 $\mu_e$  = Effective Ferrite Core Permeability  
 $X_i$  = Input Reactance  
 $Z_i$  = Input Impedance  
 $h_{em}$  = Maximum Effective Height  
CR = Core Length to Diameter Ratio

The following must be input based on known or estimated data:

$h$  = Height of Antenna above ground  
 $a$  = Radius of Antenna  
 $b$  = Radius of Conductor  
 $N$  = Number of Turns  
 $\sigma_c$  = Conductivity of Loop  
 $R_p/R_o = RR$  = Ohmic Resistance from Proximity to Ohmic Skin Effect Ratio  
 $D_{demag}$  = Demagnetization Factor  
 $\mu_f$  = Permeability of Ferrite Core  
 $f$  = Frequency of Interest  
 $i$  = Number of Increments in Degrees for Far-Field Radiation Pattern  
 $\sigma_w$  = Incident Wave Electric Field Unit Vector  
 $\sigma$  = Ground Conductivity  
 $\epsilon_r$  = Ground Relative Permittivity  
 $r_{ff}$  = Distance of Field Calculations  
 $I_o$  = Input Current at Antenna Terminals  
 $q$  = Loop Spacing  
 $cl$  = Core Length  
 $cd$  = Core Diameter

---

Enter input data here:

$\sigma_w := \begin{Bmatrix} 1 \\ 0 \\ 0 \end{Bmatrix}$	(dimensionless)	$\sigma := 6 \cdot 10^7$	(mhos / m)
$b := .01$	(meters)	$\epsilon = 1$	(dimensionless)
$i := 360$	(degrees)	$rff := 1 \cdot 10^5$	(meters)
$h := 2.5$	(meters)	$RR := .15$	(dimensionless)
$\sigma_c := 5.8 \cdot 10^7$	(mhos / m)	$cl := 1$	(meters)
$q := .03$	(meters)	$f := 3 \cdot 10^7$	(Hz)
$\frac{q}{2 \cdot b} = 1.5$	(dimensionless)	$cd := .05$	(meters)
$\mu f := 4000 \cdot (4 \cdot \pi \cdot 10^{-7})$	(Henrys / m)	$Z_0 = 50$	( $\Omega$ )
$D_{demag} := 4 \cdot 10^{-3}$	(dimensionless)	$I_0 := 1$	(amps)
$N := 6$	(dimensionless)	$a := .15$	(meters)

---

$$c = 2.9979 \cdot 10^8 \quad (\text{meters / sec})$$

$$\eta_0 = 120 \cdot \pi \quad (\Omega)$$

$$\lambda := \frac{c}{f} \quad (\text{meters / cycle})$$

$$\epsilon_0 := \frac{1}{36 \cdot \pi} \cdot 10^9 \quad (\text{Farads / m})$$

$$\lambda = 9.993 \quad (\text{meters / cycle})$$

$$\mu_0 := 4 \cdot \pi \cdot 10^{-7} \quad (\text{H / m})$$

$$S := \pi \cdot a^2 \quad (\text{m}^2)$$

$$D := 2 \cdot a \quad (\text{meters})$$

$$S = 0.07069 \quad (\text{m}^2)$$

$$D = 0.3 \quad (\text{meters})$$

$$\frac{\lambda}{6 \cdot \pi} = 0.53015 \quad (\text{meters})$$

$$CR := \frac{cl}{cd} \quad (\text{dimensionless})$$

$$C := 2 \cdot \pi \cdot a \quad (\text{meters})$$

$$\sigma_a := \begin{Bmatrix} 1 \\ 0 \\ 0 \end{Bmatrix} \quad (\text{dimensionless})$$

$$C = 0.94248 \quad (\text{meters})$$

Calculate small loop antenna parameters in free space (air core):

Define angular offset  $\theta$   
from small loop axis:

Distance to Far-Field rmin:

$$\theta := 0, \frac{2 \cdot \pi}{i} .. 2 \cdot \pi \quad (\text{radians})$$

$$r_0 := 1.6 \cdot \lambda \quad (\text{m})$$

$$r_1 := 5 \cdot D \quad (\text{m})$$

$$\phi := 0, \left\{ \frac{2 \cdot \pi}{i} \right\} .. 2 \cdot \pi \quad (\text{radians})$$

$$r_2 = \frac{2 \cdot D^2}{\lambda} \quad (\text{m})$$

$$rmin := \max(r) \quad (\text{m})$$

$$rmin = 15.9888 \quad (\text{m})$$

Wavenumber k:

$$k := \frac{2 \cdot \pi}{\lambda} \quad (\text{m}^{-1})$$

$$k = 0.62876 \quad (\text{m}^{-1})$$

Electric Field Without Ground Effects E(θ):

$$E(\theta) := \frac{k \cdot f \cdot S \cdot \mu_0 \cdot I_0 \cdot \sin(\theta)}{2 \cdot r_{ff}} \cdot e^{-j \cdot k \cdot r_{ff}} \quad (\text{V/m})$$

Radiation Intensity U(θ):

$$U(\theta) := \frac{r_{ff}^2}{2 \cdot \eta_0} \cdot (|E(\theta)|)^2 \quad (\text{W / solid angle})$$

$$U_{\max} := U\left(\frac{\pi}{2}\right) \quad (\text{W / solid angle})$$

$$U_{\max} = 9.30838 \cdot 10^{-4} \quad (\text{W / solid angle})$$

Radiated Power P<sub>rad</sub>:

$$P_{\text{rad}} := \eta_0 \cdot \frac{\pi}{12} \cdot (k \cdot a)^4 \cdot \left\{ |I_0| \right\}^2 \quad (\text{W})$$

$$P_{\text{rad}} = 7.80909 \cdot 10^{-3} \quad (\text{W})$$

$$P_{\text{rad}2} := \int_0^{2 \cdot \pi} \int_0^{\pi} U(\theta) \cdot \sin(\theta) \, d\theta \, d\phi \quad (\text{W})$$

$$P_{\text{rad}2} = 7.79817 \cdot 10^{-3} \quad (\text{W})$$

Directivity D<sub>0</sub>:

$$D_0 := 1.5 \quad (\text{dimensionless})$$

$$D_{02} := \frac{4 \cdot \pi \cdot U_{\max}}{P_{\text{rad}2}} \quad (\text{dimensionless})$$

$$D_{02} = 1.5 \quad (\text{dimensionless})$$



Radiation Resistance (Rr):

$$R_r := 20 \cdot \pi^2 \cdot \left\{ \frac{C}{\lambda} \right\}^4 \cdot N^2 \quad (\Omega)$$

$$R_r = 0.56225 \quad (\Omega)$$

$$R_{r2} := \frac{2 \cdot \text{Prad2}}{\left\{ |I_0| \right\}^2} \cdot N^2 \quad (\Omega)$$

$$R_{r2} = 0.56147 \quad (\Omega)$$

Surface Impedance of Conductor  $R_s$ :

$$R_s = \sqrt{\frac{\pi \cdot f \cdot \mu_0}{\sigma c}} \quad (\Omega)$$

$$R_s = 1.42898 \cdot 10^{-3} \quad (\Omega)$$

Ohmic Resistance  $R_{ohmic}$ :

$$R_{ohmic} = \frac{N \cdot a \cdot R_s}{b} \cdot (RR + 1) \quad (\Omega)$$

$$R_{ohmic} = 0.1479 \quad (\Omega)$$

Conduction-Dielectric Efficiency ( $\epsilon_{cd}$ ):

$$\epsilon_{cd} = \frac{R_r}{R_{ohmic} + R_r} \quad (\text{dimensionless})$$

$$\epsilon_{cd} = 0.79174 \quad (\text{dimensionless})$$

Input Reactance ( $X_i$ ):

$$X_{in} := 2 \cdot \pi \cdot f \cdot a \cdot \mu_0 \cdot \left\{ \ln \left\{ 8 \cdot \frac{a}{b} \right\} - 1.75 \right\} \quad (\Omega)$$

$$X_{in} = 1.07924 \cdot 10^2 \quad (\Omega)$$

Input Resistance ( $R_1$ ):

$$R_{in} := R_r + R_{ohmic} \quad (\Omega)$$

$$R_{in} = 0.71015 \quad (\Omega)$$

Input Impedance ( $Z_1$ ):

$$Z_i := R_{in} + X_{in} \cdot j \quad (\Omega)$$

$$Z_i = 0.71015 + 1.07924 \cdot 10^2 j \quad (\Omega)$$

Voltage Reflection Coefficient  $\Gamma$ :

$$\Gamma := \frac{Z_i - Z_0}{Z_i + Z_0} \quad (\text{dimensionless})$$

$$\Gamma = 0.64337 + 0.75901j \quad (\text{dimensionless})$$

Reflection Efficiency  $\epsilon_{rv}$ :

$$\epsilon_{rv} := 1 - (|\Gamma|)^2 \quad (\text{dimensionless})$$

$$\epsilon_{rv} = 9.98876 \cdot 10^{-3} \quad (\text{dimensionless})$$

Gain G:

$$G := \epsilon_{rv} \cdot \alpha_d \cdot D_o \quad (\text{dimensionless})$$

$$G_{db} := 10 \cdot \log(\epsilon_{rv} \cdot \alpha_d \cdot D_o) \quad (\text{dB})$$

$$G = 0.01186 \quad (\text{dimensionless})$$

$$G_{db} = -19.25817 \quad (\text{dB})$$

Maximum Effective Aperture ( $A_{em}$ ):

$$A_{em} := \frac{3 \cdot \lambda^2}{8 \cdot \pi} \quad (m^2)$$

$$A_{em} = 11.91992 \quad (m^2)$$

$$A_{em2} := \frac{\epsilon_r \cdot \epsilon_d \cdot \lambda^2 \cdot D_o}{4 \cdot \pi} \quad (m^2)$$

$$A_{em2} = 0.09427 \quad (m^2)$$

Effective Isotropic Radiated Power (EIRP):

$$EIRP := Prad \cdot D_o \quad (W)$$

$$EIRP = 0.01171 \quad (W)$$

$$EIRP2 := Prad2 \cdot D_o \quad (W)$$

$$EIRP2 = 0.0117 \quad (W)$$

Maximum Effective Height ( $h_{em}$ ):

$$h_{em} := \sqrt{\frac{R_r \cdot A_{em}}{\eta_0}} \cdot 2 \quad (m)$$

$$h_{em} = 0.26667 \quad (m)$$

$$h_{em2} := \sqrt{\frac{R_r \cdot A_{em2}}{\eta_0}} \cdot 2 \quad (m)$$

$$h_{em2} = 0.02371 \quad (m)$$

Bandwidth:

$$\text{Bandwidth} := \frac{c}{6 \cdot \pi \cdot a} \quad (Hz)$$

$$\text{Bandwidth} = 1.06029 \cdot 10^8 \quad (Hz)$$

Polarization Loss Factor PLF:

$$PLF := \left( \left| \frac{\sigma_w}{\sigma_a} \right| \right)^2 \quad (\text{dimensionless})$$

$$PLF = 1 \quad (\text{dimensionless})$$

For the purpose of this far-field radiation pattern, the small loop antenna axis is equivalent to the  $E_y = 0$  grid line. The pattern is symmetric when rotated in the  $(\phi)$  direction about the antenna's axis.

Electric Field Without Ground Effects

$$E_x(\theta) = |E(\theta)| \cdot \cos(\theta)$$

$$E_y(\theta) = |E(\theta)| \cdot \sin(\theta)$$

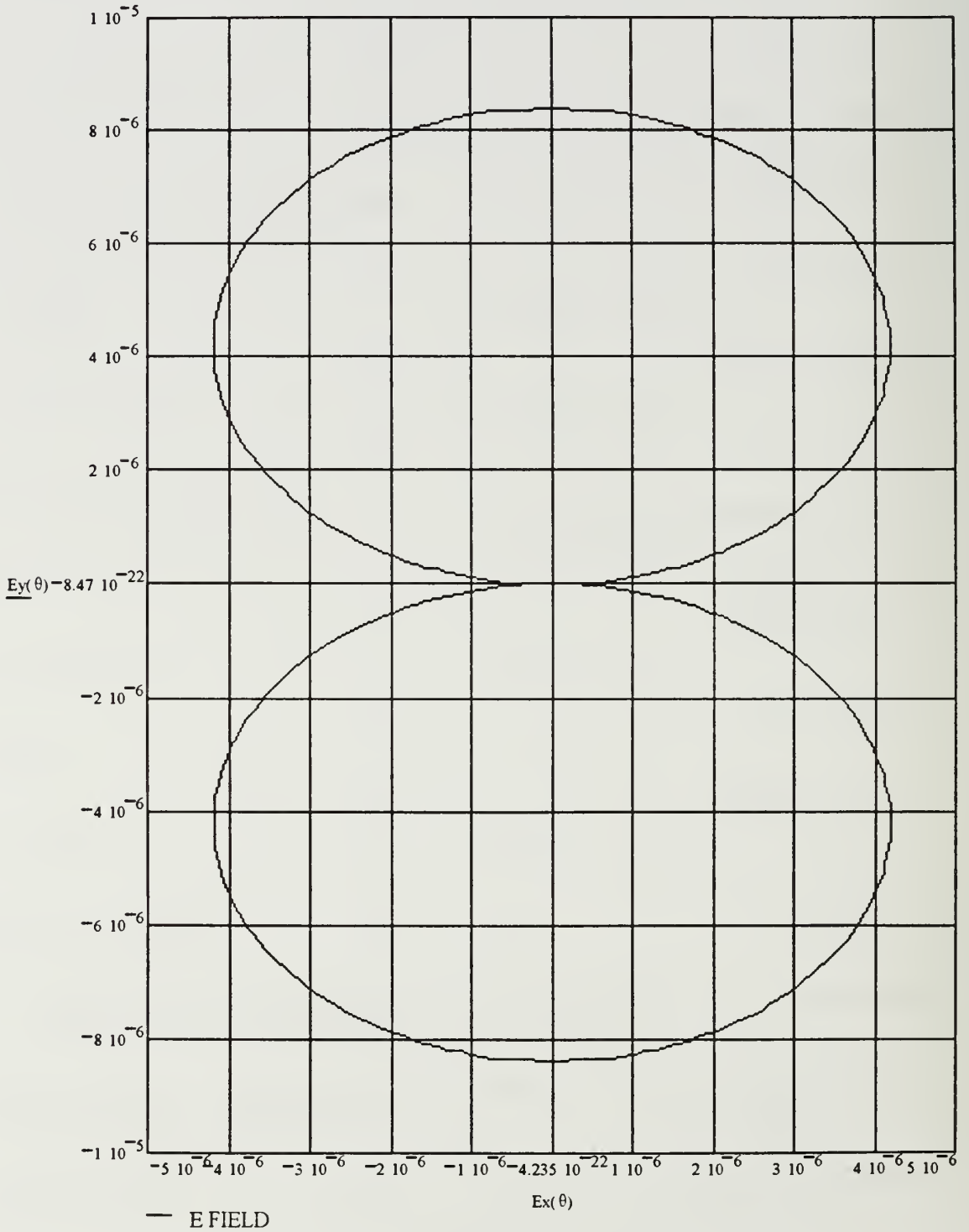

Effective Permeability ( $\mu_e$ ):

$$\mu_e := \frac{\mu f}{1 + D_{\text{demag}} \cdot (\mu f - 1)} \quad (\text{Henrys/m})$$

$$\mu_e = 5.04663 \cdot 10^{-3} \quad (\text{Henrys/m})$$

Electric Field Without Ground Effects  $E(\theta)$ :

$$E(\theta) := \frac{k \cdot f \cdot S \cdot \mu_e \cdot I_0 \cdot \sin(\theta)}{2 \cdot r_{\text{ff}}} \cdot e^{-j \cdot k \cdot r_{\text{ff}}} \quad (\text{V/m})$$

Radiation Intensity  $U(\theta)$ :

$$U(\theta) := \frac{r_{\text{ff}}^2}{2 \cdot \eta_0} \cdot (|E(\theta)|)^2 \quad (\text{W / solid angle})$$

$$U_{\text{max}} := U\left\{\frac{\pi}{2}\right\} \quad (\text{W / solid angle})$$

$$U_{\text{max}} = 1.50127 \cdot 10^4 \quad (\text{W / solid angle})$$

Radiated Power  $P_{\text{rad}}$ :

$$P_{\text{rad}} := \int_0^{2\pi} \int_0^{\pi} U(\theta) \cdot \sin(\theta) \, d\theta \, d\phi \quad (\text{W})$$

$$P_{\text{rad}} = 1.2577 \cdot 10^5 \quad (\text{W})$$

Directivity  $D_0$ :

$$D_0 := 1.5 \quad (\text{dimensionless})$$

$$D_0 := \frac{4 \cdot \pi \cdot U_{\text{max}}}{P_{\text{rad}}} \quad (\text{dimensionless})$$

$$D_0 = 1.5 \quad (\text{dimensionless})$$

Radiation Resistance (Rr):

$$R_r = 20 \pi^2 \left( \frac{C}{\lambda} \right)^4 \cdot N^2 \cdot \left( \frac{\mu e}{\mu_0} \right)^2 \quad (\Omega)$$

$$R_r = 9.06811 \cdot 10^6 \quad (\Omega)$$

$$R_{r2} := \frac{2 \cdot \text{Prad}}{\left( |I_0| \right)^2} \cdot N^2 \quad (\Omega)$$

$$R_{r2} = 9.05542 \cdot 10^6 \quad (\Omega)$$

Surface Impedance of Conductor R<sub>s</sub>:

$$R_s := \sqrt{\frac{\pi \cdot f \cdot \mu e}{\sigma c}} \quad (\Omega)$$

$$R_s = 0.09056 \quad (\Omega)$$

Ohmic Resistance R<sub>ohmic</sub>:

$$R_{ohmic} = \frac{N \cdot a \cdot R_s}{b} \cdot (RR + 1) \quad (\Omega)$$

$$R_{ohmic} = 9.37266 \quad (\Omega)$$

Conduction-Dielectric Efficiency (ε<sub>cd</sub>):

$$\epsilon_{cd} := \frac{R_r}{R_{ohmic} + R_r} \quad (\text{dimensionless})$$

$$\epsilon_{cd} = 1 \quad (\text{dimensionless})$$

Input Reactance (X<sub>i</sub>):

$$X_{in} = 2 \cdot \pi \cdot f \cdot a \cdot \mu e \cdot \left( \ln \left( 8 \frac{a}{b} \right) - 1.75 \right) \quad (\Omega)$$

$$X_{in} = 4.3342 \cdot 10^5 \quad (\Omega)$$

Input Resistance ( $R_{i1}$ ):

$$R_{in} := R_r + R_{ohmic} \quad (\Omega)$$

$$R_{in} = 9.06812 \cdot 10^6 \quad (\Omega)$$

Input Impedance ( $Z_i$ ):

$$Z_i := R_{in} + X_{in} \cdot j \quad (\Omega)$$

$$Z_i = 9.06812 \cdot 10^6 + 4.3342 \cdot 10^5 j \quad (\Omega)$$

Voltage Reflection Coefficient  $\Gamma$ :

$$\Gamma := \frac{Z_i - Z_0}{Z_i + Z_0} \quad (\text{dimensionless})$$

$$\Gamma = 0.99999 + 5.2587 \cdot 10^{-7} j \quad (\text{dimensionless})$$

Reflection Efficiency  $\epsilon_{rv}$ :

$$\epsilon_{rv} := 1 - (|\Gamma|)^2 \quad (\text{dimensionless})$$

$$\epsilon_{rv} = 2.20048 \cdot 10^{-5} \quad (\text{dimensionless})$$

Gain G:

$$G := \epsilon_{rv} \cdot \alpha_d \cdot D_o \quad (\text{dimensionless})$$

$$G_{db} = 10 \cdot \log(\epsilon_{rv} \cdot \alpha_d \cdot D_o) \quad (\text{dB})$$

$$G = 3.30071 \cdot 10^{-5} \quad (\text{dimensionless})$$

$$G_{db} = -44.81392 \quad (\text{dB})$$

Maximum Effective Aperture ( $A_{em}$ ):

$$A_{em} := \frac{\epsilon_{rv} \cdot \alpha_d \cdot \lambda^2 \cdot D_o}{4 \cdot \pi} \quad (\text{m}^2)$$

$$A_{em} = 2.62295 \cdot 10^{-4} \quad (\text{m}^2)$$



Effective Isotropic Radiated Power (EIRP):

$$\text{EIRP} := \text{Prad} \cdot \text{Do} \quad (\text{W})$$

$$\text{EIRP} = 1.88655 \cdot 10^5 \quad (\text{W})$$

Bandwidth BW:

$$\text{Bandwidth} := \frac{c}{6 \cdot \pi \cdot a} \quad (\text{Hz})$$

$$\text{Bandwidth} = 1.06029 \cdot 10^8 \quad (\text{Hz})$$

Maximum Effective Height ( $h_{em}$ ):

$$h_{em} := \sqrt{\frac{R_r \cdot A_{em}}{\eta_0}} \cdot 2 \quad (\text{m})$$

$$h_{em} = 5.02363 \quad (\text{m})$$

Polarization Loss Factor PLF:

$$\text{PLF} := \left( \left| \frac{\sigma_w}{\sigma_a} \right| \right)^2 \quad (\text{dimensionless})$$

$$\text{PLF} = 1 \quad (\text{dimensionless})$$

For the purpose of this far-field radiation pattern, the small loop antenna axis is equivalent to the  $E_y = 0$  grid line. The pattern is symmetric when rotated in the ( $\phi$ ) direction about the antenna's axis.

Electric Field Without Ground Effects

$$E_x(\theta) := |E(\theta)| \cdot \cos(\theta)$$

$$E_y(\theta) := |E(\theta)| \cdot \sin(\theta)$$

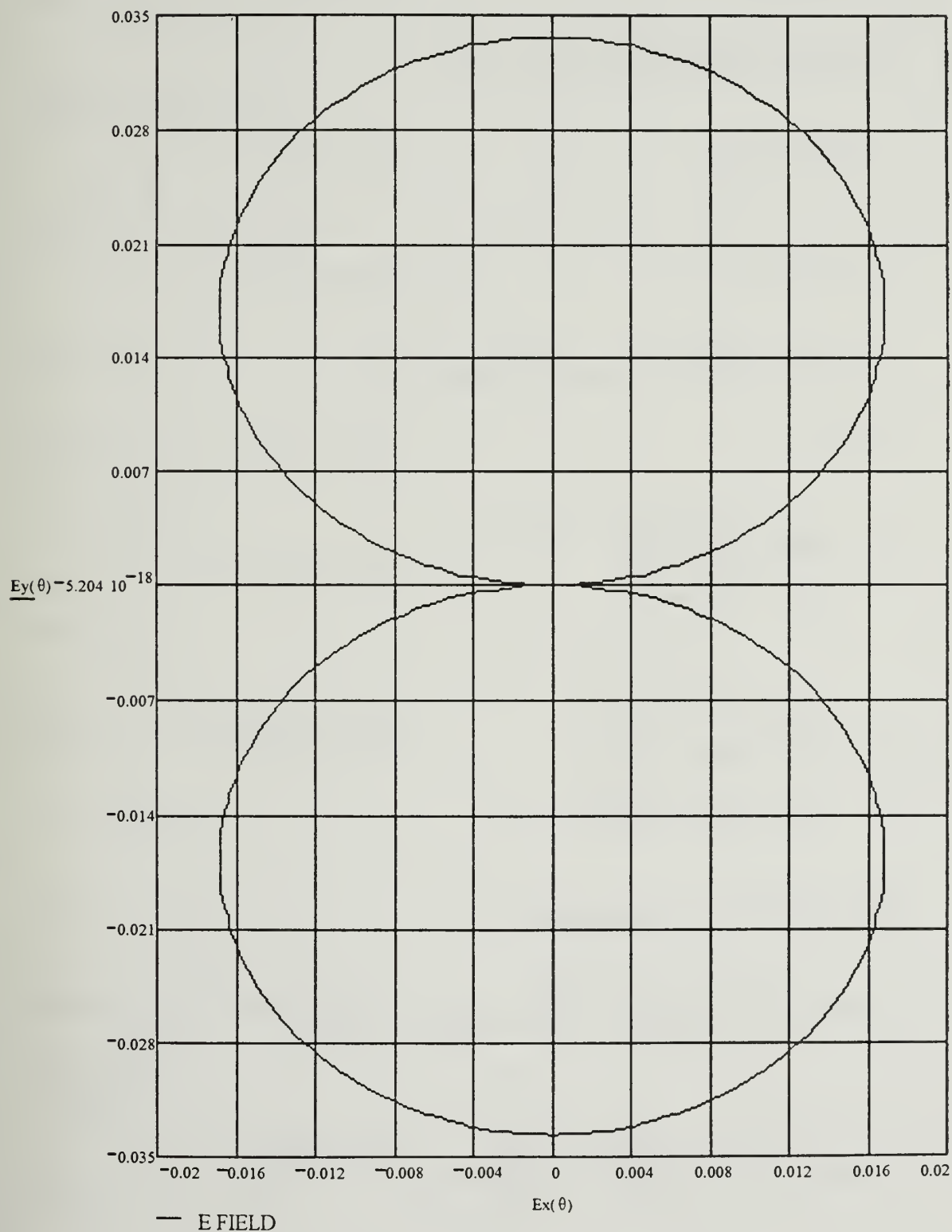

Calculate small horizontal loop antenna parameters over ground (air core):

Define angular offset  $\theta$  from small loop axis:

$$\theta := -\frac{\pi}{2}, -\frac{\pi}{2} + \frac{\pi}{i} \dots \frac{\pi}{2} \quad (\text{radians})$$

$$\phi := 0, \left\{ \frac{2 \cdot \pi}{i} \right\} \dots 2 \cdot \pi \quad (\text{radians})$$

Relative Complex Permittivity ( $\epsilon_r$ ):

$$\epsilon_r := \epsilon - j \cdot \frac{\sigma}{2 \cdot \pi \cdot f \cdot \epsilon_0} \quad (\text{dimensionless})$$

$$\epsilon_r = -3.6 \cdot 10^{10} j \quad (\text{dimensionless})$$

Horizontal Reflection Coefficient ( $\Gamma_h$ ):

$$m := 0 \dots \frac{i}{2} \quad (\text{increments})$$

$$\Gamma_h(\theta) := \frac{\cos(\theta) - \sqrt{\epsilon_r - \sin^2(\theta)}}{\cos(\theta) + \sqrt{\epsilon_r - \sin^2(\theta)}} \quad (\text{dimensionless})$$

$$\Gamma_h|_m := \frac{\cos\left(\frac{m \cdot \pi}{i}\right) - \sqrt{\epsilon_r - \sin^2\left(\frac{m \cdot \pi}{i}\right)}}{\cos\left(\frac{m \cdot \pi}{i}\right) + \sqrt{\epsilon_r - \sin^2\left(\frac{m \cdot \pi}{i}\right)}} \quad (\text{dimensionless})$$

Total Electric Field ( $E_{\text{thor}}$ ):

$$E_{\text{thor}}(\theta) := \left\{ \frac{k \cdot S \cdot f \cdot \mu_0 \cdot I_0 \cdot \sin(\theta) \cdot e^{-j \cdot k \cdot r_{\text{eff}}}}{2 \cdot r_{\text{eff}}} \right\} \cdot \left\{ 1 - \Gamma_h(\theta) \cdot e^{-j \cdot 2 \cdot k \cdot h \cdot \cos(\theta)} \right\} \quad (\text{V/m})$$

$$E_{\text{thor}}|_m := \left\| \left\{ \frac{k \cdot S \cdot f \cdot \mu_0 \cdot I_0 \cdot \sin\left(\frac{m \cdot \pi}{i}\right) \cdot e^{-j \cdot k \cdot r_{\text{eff}}}}{2 \cdot r_{\text{eff}}} \right\} \cdot \left\{ 1 - \Gamma_h|_m \cdot e^{-j \cdot 2 \cdot k \cdot h \cdot \frac{\cos(m \cdot i)}{\pi}} \right\} \right\| \quad (\text{V/m})$$

Radiation Intensity U( $\theta$ ):

$$U(\theta) := \frac{rff^2}{2 \cdot \eta_0} \cdot (|E_{\theta}(\theta)|)^2 \quad (\text{W / solid angle})$$

$$U_{\max} := \frac{rff^2}{2 \cdot \eta_0} \cdot (|\max(E_{\theta 1})|)^2 \quad (\text{W / solid angle})$$

$$U_{\max} = 3.7199 \cdot 10^{-3} \quad (\text{W / solid angle})$$

Radiated Power P<sub>rad</sub>:

$$P_{\text{rad}} := \int_0^{2 \cdot \pi} \int_0^{\frac{\pi}{2}} |U(\theta) \cdot \sin(\theta)| \, d\theta \, d\phi \quad (\text{W})$$

$$P_{\text{rad}} = 0.01016 \quad (\text{W})$$

Directivity D<sub>o</sub>:

$$D_o := \frac{4 \cdot \pi \cdot U_{\max}}{P_{\text{rad}}} \quad (\text{dimensionless})$$

$$D_o = 4.59936 \quad (\text{dimensionless})$$

Polarization Loss Factor (PLF):

$$PLF := \left( \left| \frac{\sigma_w}{\sigma_a} \right| \right)^2 \quad (\text{dimensionless})$$

$$PLF = 1 \quad (\text{dimensionless})$$

Radiation Resistance (R<sub>r</sub>):

$$R_r := \frac{2 \cdot P_{\text{rad}}}{\left( |I_0| \right)^2} \cdot N^2 \quad (\Omega)$$

$$R_r = 0.73177 \quad (\Omega)$$

Surface Impedance of Conductor  $R_s$ :

$$R_s = \sqrt{\frac{\pi \cdot f \cdot \mu_0}{\sigma c}} \quad (\Omega)$$

$$R_s = 1.42898 \cdot 10^{-3} \quad (\Omega)$$

Ohmic Resistance  $R_{ohmic}$ :

$$R_{ohmic} := \frac{N \cdot a \cdot R_s}{b} \cdot (RR + 1) \quad (\Omega)$$

$$R_{ohmic} = 0.1479 \quad (\Omega)$$

Conduction-Dielectric Efficiency ( $\epsilon_{cd}$ ):

$$\epsilon_{cd} = \frac{R_r}{R_{ohmic} + R_r} \quad (\text{dimensionless})$$

$$\epsilon_{cd} = 0.83187 \quad (\text{dimensionless})$$

Input Reactance ( $X_i$ ):

$$X_{in} := 2 \cdot \pi \cdot f \cdot a \cdot \mu_0 \cdot \left\{ \ln \left( 8 \cdot \frac{a}{b} \right) - 1.75 \right\} \quad (\Omega)$$

$$X_{in} = 1.07924 \cdot 10^2 \quad (\Omega)$$

Input Resistance ( $R_i$ ):

$$R_{in} = R_r + R_{ohmic} \quad (\Omega)$$

$$R_{in} = 0.87967 \quad (\Omega)$$

Input Impedance ( $Z_i$ ):

$$Z_i := R_{in} + X_{in} \cdot j \quad (\Omega)$$

$$Z_i = 0.87967 + 1.07924 \cdot 10^2 j \quad (\Omega)$$

Voltage Reflection Coefficient  $\Gamma$ :

$$\Gamma := \frac{Z_i - Z_0}{Z_i + Z_0} \quad (\text{dimensionless})$$

$$\Gamma = 0.64261 + 0.75809j \quad (\text{dimensionless})$$

Reflection Efficiency  $\epsilon_{rv}$ :

$$\epsilon_{rv} := 1 - (|\Gamma|)^2 \quad (\text{dimensionless})$$

$$\epsilon_{rv} = 0.01236 \quad (\text{dimensionless})$$

Gain G:

$$G := \epsilon_{rv} \cdot \omega \cdot D_o \quad (\text{dimensionless})$$

$$G_{db} := 10 \cdot \log(\epsilon_{rv} \cdot \omega \cdot D_o) \quad (\text{dB})$$

$$G = 0.04728 \quad (\text{dimensionless})$$

$$G_{db} = -13.25293 \quad (\text{dB})$$

Maximum Effective Aperture ( $A_{em}$ ):

$$A_{em} := \frac{\epsilon_{rv} \cdot \omega \cdot \lambda^2 \cdot D_o \cdot (PLF)}{4 \cdot \pi} \quad (\text{m}^2)$$

$$A_{em} = 0.37574 \quad (\text{m}^2)$$

Effective Isotropic Radiated Power (EIRP):

$$\text{EIRP} := \text{Prad} \cdot D_o \quad (\text{W})$$

$$\text{EIRP} = 0.04675 \quad (\text{W})$$

Bandwidth:

$$\text{Bandwidth} := \frac{c}{6 \cdot \pi \cdot a} \quad (\text{Hz})$$

$$\text{Bandwidth} = 1.06029 \cdot 10^8 \quad (\text{Hz})$$

Maximum Effective Height ( $h_{em}$ ):

$$h_{em} := \sqrt{\frac{R_r \cdot A_{em}}{\eta_0}} \cdot 2 \quad (\text{m})$$

$$h_{em} = 0.05401 \quad (\text{m})$$

SMALL HORIZONTAL LOOP ANTENNA FAR FIELD PATTERN ABOVE GROUND WITH AIR CORE

For the purpose of this far-field radiation pattern, the small loop antenna axis is equivalent to the  $E_x = 0$  grid line. The pattern is symmetric when rotated in the  $(\phi)$  direction about the antenna's axis.

Small Horizontal Loop with Air Core Electric  
Over Real Ground

$$E_x(\theta) := |E_{\theta}(\theta)| \cdot \cos\left\{\theta + \frac{\pi}{2}\right\} \qquad E_y(\theta) := |E_{\theta}(\theta)| \cdot \sin\left\{\theta + \frac{\pi}{2}\right\}$$

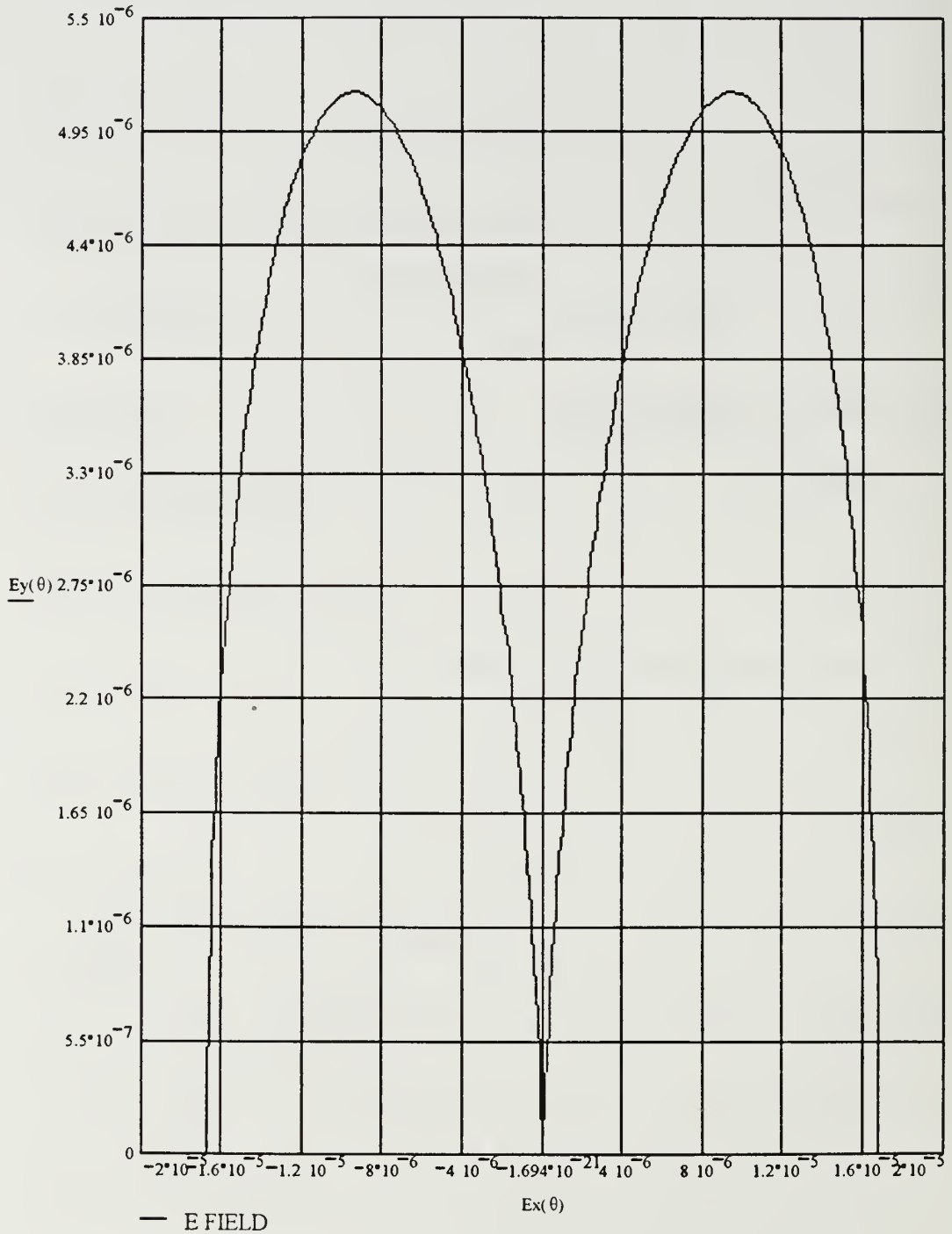



Incremental Horizontal Reflection Coefficient (Gamma\_h):

$m = 0.. \frac{i}{2}$  (increments)

$$\Gamma_{h_m} := \frac{\cos\left(\frac{m \cdot \pi}{i}\right) - \sqrt{\sigma p - \sin\left(\frac{m \cdot \pi}{i}\right)^2}}{\cos\left(\frac{m \cdot \pi}{i}\right) + \sqrt{\sigma p - \sin\left(\frac{m \cdot \pi}{i}\right)^2}}$$
 (dimensionless)

Total Electric Field (E\_thor):

$$E_{thor}(\theta) = \left\{ \frac{k \cdot S \cdot f \cdot \mu \epsilon \cdot I_0 \cdot \sin(\theta) \cdot e^{-j \cdot k \cdot r_{ff}}}{2 \cdot r_{ff}} \right\} \cdot \left\{ 1 - \Gamma_h(\theta) \cdot e^{-j \cdot 2 \cdot k \cdot h \cdot \cos(\theta)} \right\}$$
 (V/m)

$$E_{thor1}_m = \left| \left\{ \frac{k \cdot S \cdot f \cdot \mu \epsilon \cdot I_0 \cdot \sin\left(\frac{m \cdot \pi}{i}\right) \cdot e^{-j \cdot k \cdot r_{ff}}}{2 \cdot r_{ff}} \right\} \cdot \left\{ 1 - \Gamma_{h_m} \cdot e^{-j \cdot 2 \cdot k \cdot h \cdot \frac{\cos(m \cdot i)}{\pi}} \right\} \right|$$
 (V/m)

Radiation Intensity U(theta):

$$U(\theta) := \frac{r_{ff}^2}{2 \cdot \eta_0} \cdot (|E_{thor}(\theta)|)^2$$
 (W / solid angle)

$$U_{max} := \frac{r_{ff}^2}{2 \cdot \eta_0} \cdot (|\max(E_{thor1})|)^2$$
 (W / solid angle)

$$U_{max} = 5.9995 \cdot 10^4$$
 (W / solid angle)

Radiated Power P\_rad:

$$Prad = \int_0^{2 \cdot \pi} \int_0^{\frac{\pi}{2}} |U(\theta) \cdot \sin(\theta)| \, d\theta \, d\phi$$
 (W)

$$Prad = 1.63918 \cdot 10^5$$
 (W)

Directivity D\_o:

$$D_o := \frac{4 \cdot \pi \cdot U_{max}}{Prad}$$
 (dimensionless)

$$D_o = 4.59936$$
 (dimensionless)

Radiation Resistance (Rr):

$$R_r := \frac{2 \cdot \text{Prad}}{\left( \left| I_0 \right| \right)^2} \cdot N^2 \quad (\Omega)$$

$$R_r = 1.18021 \cdot 10^7 \quad (\Omega)$$

Surface Impedance of Conductor R<sub>s</sub>:

$$R_s := \sqrt{\frac{\pi \cdot f \cdot \mu \epsilon}{\sigma c}} \quad (\Omega)$$

$$R_s = 0.09056 \quad (\Omega)$$

Ohmic Resistance R<sub>ohmic</sub>:

$$R_{ohmic} := \frac{N \cdot a \cdot R_s}{b} \cdot (RR + 1) \quad (\Omega)$$

$$R_{ohmic} = 9.37266 \quad (\Omega)$$

Conduction-Dielectric Efficiency (ε<sub>cd</sub>):

$$\epsilon_{cd} := \frac{R_r}{R_{ohmic} + R_r} \quad (\text{dimensionless})$$

$$\epsilon_{cd} = 1 \quad (\text{dimensionless})$$

Input Reactance (X<sub>i</sub>):

$$X_{in} := 2 \cdot \pi \cdot f \cdot a \cdot \mu \epsilon \cdot \left\{ \ln \left( 8 \cdot \frac{a}{b} \right) - 1.75 \right\} \quad (\Omega)$$

$$X_{in} = 4.3342 \cdot 10^5 \quad (\Omega)$$

Input Resistance (R<sub>i</sub>):

$$R_{in} := R_r + R_{ohmic} \quad (\Omega)$$

$$R_{in} = 1.18021 \cdot 10^7 \quad (\Omega)$$

Voltage Reflection Coefficient Γ:

$$\Gamma := \frac{Z_i - Z_0}{Z_i + Z_0} \quad (\text{dimensionless})$$

$$\Gamma = 0.64261 + 0.75809j \quad (\text{dimensionless})$$

Reflection Efficiency  $\epsilon_{rv}$ :

$\epsilon_{rv} := 1 - (|\Gamma|)^2$  (dimensionless)

$\epsilon_{rv} = 0.01236$  (dimensionless)

Gain G:

$G := \epsilon_{rv} \cdot \omega_d \cdot D_o$  (dimensionless)

$G_{db} := 10 \cdot \log(\epsilon_{rv} \cdot \omega_d \cdot D_o)$  (dB)

$G = 0.05684$  (dimensionless)

$G_{db} = -12.45349$  (dB)

Maximum Effective Aperture ( $A_{em}$ ):

$A_{em} := \frac{\epsilon_{rv} \cdot \omega_d \cdot \lambda^2 \cdot D_o \cdot (PLF)}{4 \cdot \pi}$  (m<sup>2</sup>)

$A_{em} = 0.45168$  (m<sup>2</sup>)

Effective Isotropic Radiated Power (EIRP):

$EIRP := Prad \cdot D_o$  (W)

$EIRP = 7.5392 \cdot 10^5$  (W)

Bandwidth BW:

$BW = \frac{c}{6 \cdot \pi \cdot a}$  (Hz)

$BW = 1.06029 \cdot 10^8$  (Hz)

Maximum Effective Height ( $h_{em}$ ):

$h_{em} := \sqrt{\frac{R_r \cdot A_{em}}{\eta_0}} \cdot 2$  (m)

$h_{em} = 2.37827 \cdot 10^2$  (m)

Polarization Loss Factor (PLF):

$PLF := \left( \left| \frac{\sigma_w}{\sigma_a} \right| \right)^2$  (dimensionless)

$PLF = 1$  (dimensionless)

SMALL HORIZONTAL LOOP ANTENNA FAR FIELD PATTERN ABOVE GROUND WITH FERRITE CORE

For the purpose of this far-field radiation pattern, the small loop antenna axis is equivalent to the  $E_x = 0$  grid line. The pattern is symmetric when rotated in the  $(\phi)$  direction about the antenna's axis.

Small Horizontal Loop with Ferrite Core  
Electric Over Real Ground

$$E_x(\theta) := |E_{\theta}(\theta)| \cdot \cos\left\{\theta + \frac{\pi}{2}\right\} \qquad E_y(\theta) := |E_{\theta}(\theta)| \cdot \sin\left\{\theta + \frac{\pi}{2}\right\}$$

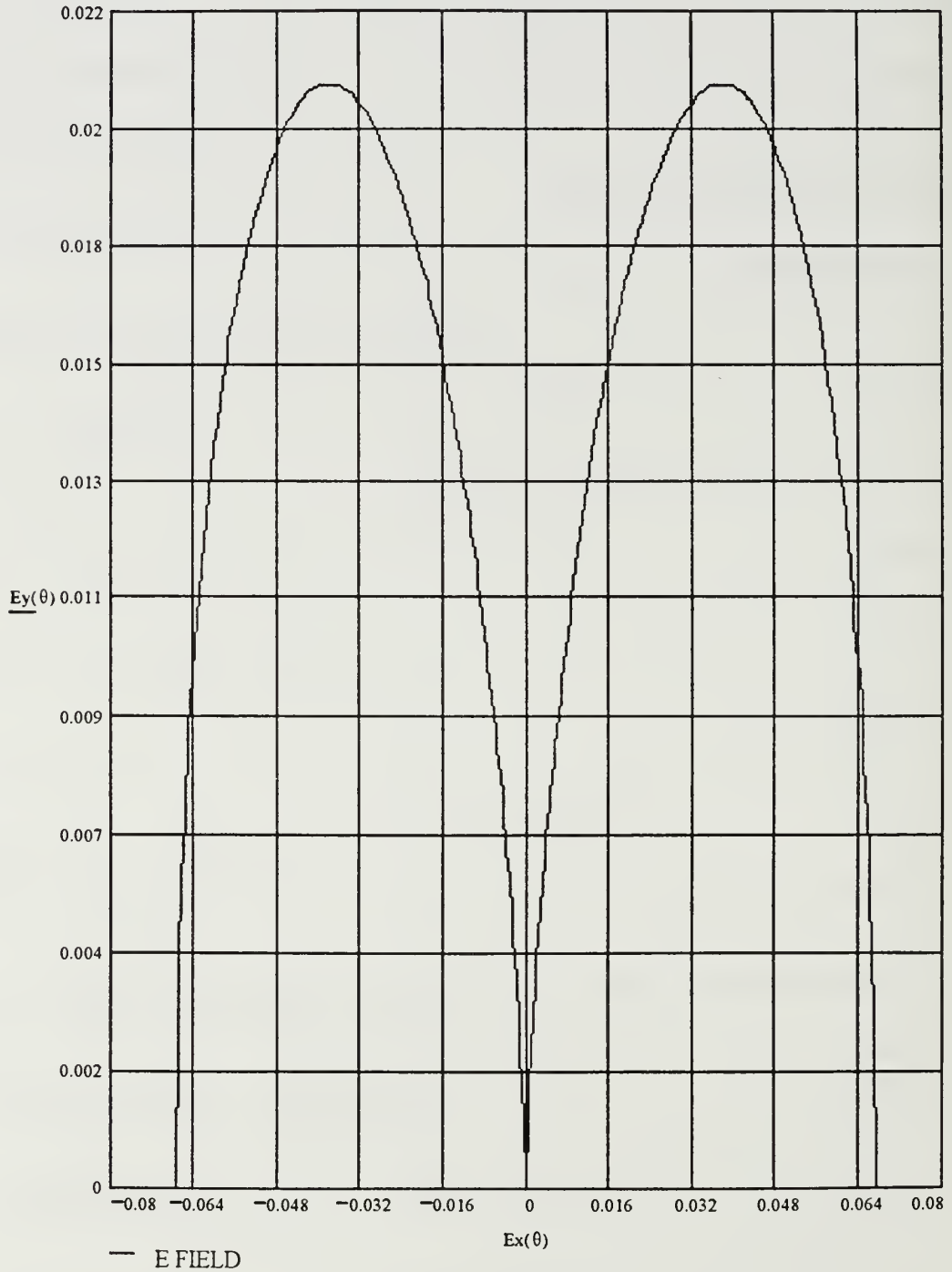

Define angular offset  $\theta$   
from small loop axis:

$$\theta := 0, \frac{\pi}{i} \dots \pi \quad (\text{radians})$$

$$\phi := 0, \frac{\pi}{i} \dots \pi \quad (\text{radians})$$

Relative Complex Permittivity ( $\epsilon_r$ ):

$$\epsilon_r := \epsilon - j \cdot \frac{\sigma}{2 \cdot \pi \cdot f \cdot \epsilon_0} \quad (\text{dimensionless})$$

$$\epsilon_r = -3.6 \cdot 10^{10} j \quad (\text{dimensionless})$$

Vertical Reflection Coefficient ( $\Gamma_v$ ):

$$\Gamma_v(\theta) := \frac{\epsilon_r \cdot \cos\left(\left\{\frac{\pi}{2} - \theta\right\}\right) - \sqrt{\epsilon_r - \sin\left(\frac{\pi}{2} - \theta\right)^2}}{\epsilon_r \cdot \cos\left(\left\{\frac{\pi}{2} - \theta\right\}\right) + \sqrt{\epsilon_r - \sin\left(\frac{\pi}{2} - \theta\right)^2}} \quad (\text{dimensionless})$$

$$m := 0 \dots i \quad (\text{increments})$$

$$|\Gamma_v|_m := \frac{\epsilon_r \cdot \cos\left(\left\{\frac{\pi}{2} - \frac{m \cdot \pi}{i}\right\}\right) - \sqrt{\epsilon_r - \sin\left(\frac{\pi}{2} - \frac{m \cdot \pi}{i}\right)^2}}{\epsilon_r \cdot \cos\left(\left\{\frac{\pi}{2} - \frac{m \cdot \pi}{i}\right\}\right) + \sqrt{\epsilon_r - \sin\left(\frac{\pi}{2} - \frac{m \cdot \pi}{i}\right)^2}} \quad (\text{dimensionless})$$

Total Electric Field ( $E_{\text{vert}}$ ):

$$E_{\text{vert}}(\theta) := \left\{ \frac{k \cdot S \cdot f \cdot \mu_0 \cdot I_0 \cdot \sin(\theta) \cdot e^{-j \cdot k \cdot r_{\text{eff}}}}{2 \cdot r_{\text{eff}}} \right\} \cdot \left\{ 1 + \Gamma_v(\theta) \cdot e^{-j \cdot 2 \cdot k \cdot h \cdot \cos(\theta)} \right\} \quad (\text{V/m})$$

$$E_{\text{vert}}|_m := \left| \left\{ \frac{k \cdot S \cdot f \cdot \mu_0 \cdot I_0 \cdot \sin\left(\frac{m \cdot \pi}{i}\right) \cdot e^{-j \cdot k \cdot r_{\text{eff}}}}{2 \cdot r_{\text{eff}}} \right\} \cdot \left\{ 1 + |\Gamma_v|_m \cdot e^{-j \cdot 2 \cdot k \cdot h \cdot \cos\left(\frac{m \cdot \pi}{i}\right)} \right\} \right| \quad (\text{V/m})$$

Radiation Intensity U( $\theta$ ):

$$U(\theta) := \frac{rff^2}{2 \cdot \eta_0} \cdot (|E_{\text{vert}}(\theta)|)^2 \quad (\text{W / solid angle})$$

$$U_{\text{max}} := \frac{rff^2}{2 \cdot \eta_0} \cdot (|\text{max}(E_{\text{vert}})|)^2 \quad (\text{W / solid angle})$$

$$U_{\text{max}} = 3.72332 \cdot 10^{-3} \quad (\text{W / solid angle})$$

Radiated Power P<sub>rad</sub>:

$$P_{\text{rad}} := \int_0^\pi \int_0^\pi |U(\theta) \cdot \sin(\theta)| \, d\theta \, d\phi \quad (\text{W})$$

$$P_{\text{rad}} = 0.01016 \quad (\text{W})$$

Directivity D<sub>o</sub>:

$$D_o := \frac{4 \cdot \pi \cdot U_{\text{max}}}{P_{\text{rad}}} \quad (\text{dimensionless})$$

$$D_o = 4.60367 \quad (\text{dimensionless})$$

Radiation Resistance (R<sub>r</sub>):

$$R_r := \frac{2 \cdot P_{\text{rad}}}{(|I_0|)^2} \cdot N^2 \quad (\Omega)$$

$$R_r = 0.73176 \quad (\Omega)$$

Surface Impedance of Conductor R<sub>s</sub>:

$$R_s := \sqrt{\frac{\pi \cdot f \cdot \mu_0}{\sigma c}} \quad (\Omega)$$

$$R_s = 1.42898 \cdot 10^{-3} \quad (\Omega)$$

Ohmic Resistance  $R_{ohmic}$ :

$$R_{ohmic} = \frac{N \cdot a \cdot R_s}{b} \cdot (RR + 1) \quad (\Omega)$$

$$R_{ohmic} = 0.1479 \quad (\Omega)$$

Conduction-Dielectric Efficiency ( $\epsilon_{cd}$ ):

$$\epsilon_{cd} = \frac{R_r}{R_{ohmic} + R_r} \quad (\text{dimensionless})$$

$$\epsilon_{cd} = 0.83187 \quad (\text{dimensionless})$$

Input Reactance ( $X_i$ ):

$$X_{in} := 2 \cdot \pi \cdot f \cdot a \cdot \mu_0 \cdot \left\{ \ln \left\{ 8 \frac{a}{b} \right\} - 1.75 \right\} \quad (\Omega)$$

$$X_{in} = 1.07924 \cdot 10^2 \quad (\Omega)$$

Input Resistance ( $R_i$ ):

$$R_{in} = R_r + R_{ohmic} \quad (\Omega)$$

$$R_{in} = 0.87966 \quad (\Omega)$$

Voltage Reflection Coefficient  $\Gamma$ :

$$\Gamma = \frac{Z_i - Z_0}{Z_i + Z_0} \quad (\text{dimensionless})$$

$$\Gamma = 0.64261 + 0.75809j \quad (\text{dimensionless})$$

Reflection Efficiency  $\epsilon_{rv}$ :

$$\epsilon_{rv} = 1 - (|\Gamma|)^2 \quad (\text{dimensionless})$$

$$\epsilon_{rv} = 0.01236 \quad (\text{dimensionless})$$



Gain G:

$G = \epsilon v \cdot \omega d \cdot D_o$  (dimensionless)

$G_{db} := 10 \cdot \log(\epsilon v \cdot \omega d \cdot D_o)$  (dB)

$G = 0.04733$  (dimensionless)

$G_{db} = -13.24888$  (dB)

Maximum Effective Aperture ( $A_{em}$ ):

$A_{em} := \frac{\epsilon v \cdot \omega d \cdot \lambda^2 \cdot D_o \cdot (PLF)}{4 \cdot \pi}$  (m<sup>2</sup>)

$A_{em} = 0.37609$  (m<sup>2</sup>)

Effective Isotropic Radiated Power (EIRP):

$EIRP = Prad \cdot D_o$  (W)

$EIRP = 0.04679$  (W)

Bandwidth:

$Bandwidth := \frac{c}{6 \cdot \pi \cdot a}$  (Hz)

$Bandwidth = 1.06029 \cdot 10^8$  (Hz)

Maximum Effective Height ( $h_{em}$ ):

$h_{em} := \sqrt{\frac{Rr \cdot A_{em}}{\eta_0}} \cdot 2$  (m)

$h_{em} = 0.05404$  (m)

Polarization Loss Factor (PLF):

$\sigma_a := \begin{Bmatrix} 0 \\ 1 \\ 0 \end{Bmatrix}$  (dimensionless)

$\sigma_w := \begin{Bmatrix} 0 \\ 1 \\ 0 \end{Bmatrix}$  (dimensionless)

$PLF := \left( \left| \sigma_w \cdot \sigma_a \right| \right)^2$  (dimensionless)

$PLF = 1$  (dimensionless)

For the purpose of this far-field radiation pattern, the small loop antenna axis is equivalent to the  $E_y = 0$  grid line. The pattern is symmetric when rotated in the ( $\phi$ ) direction about the antenna's axis.

Small Vertical Loop with Air Core Electric  
Over Real Ground

$$E_x(\theta) := |E_{\text{vert}}(\theta)| \cdot \cos(\theta)$$

$$E_y(\theta) := |E_{\text{vert}}(\theta)| \cdot \sin(\theta)$$

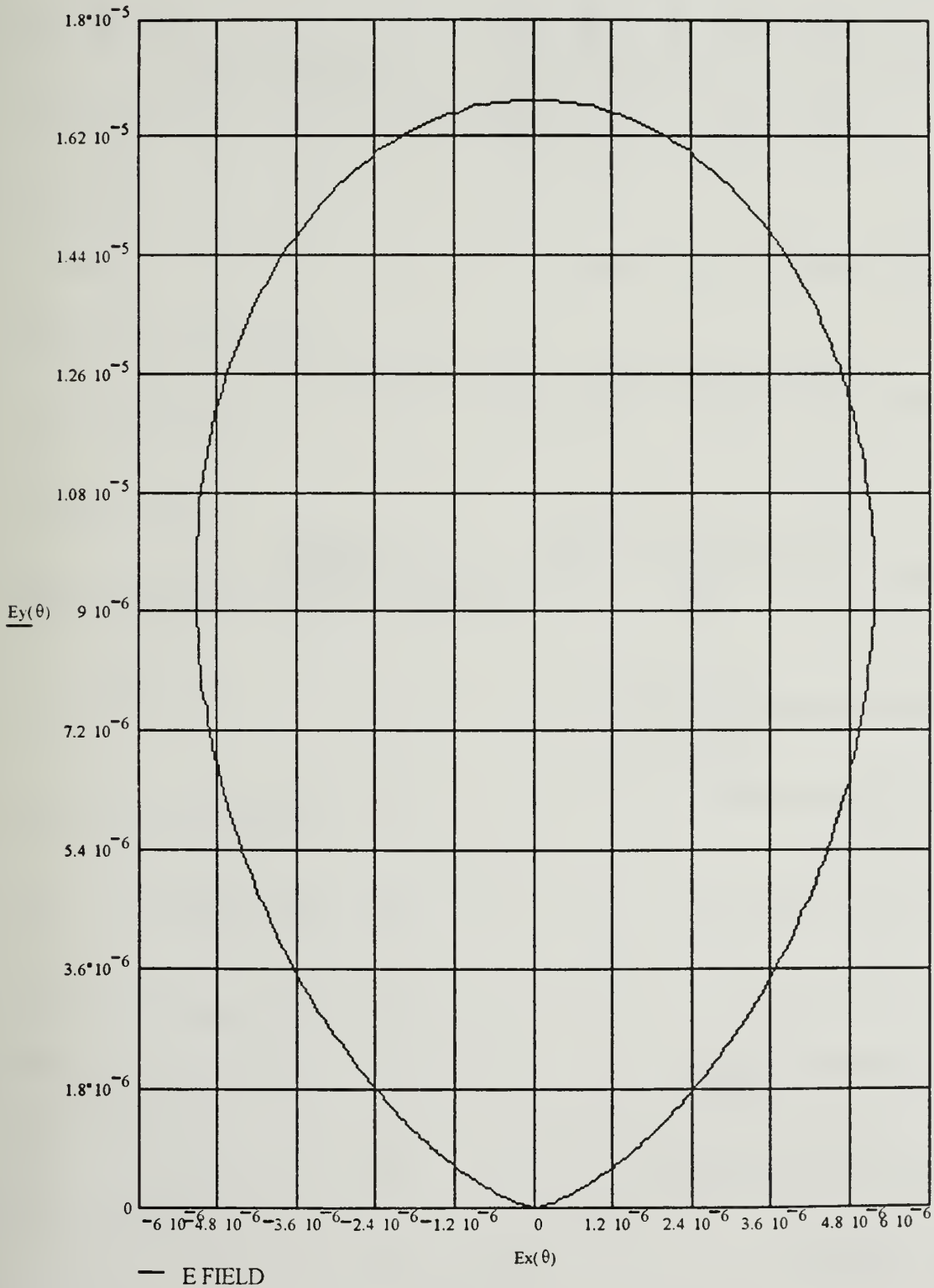

Calculate small vertical loop antenna parameters over ground (ferrite core):

Vertical Reflection Coefficient ( $\Gamma_v$ ):

$$\Gamma_v(\theta) := \frac{\exp\left(\cos\left(\frac{\pi}{2} - \theta\right)\right) - \sqrt{\exp\left(\sin\left(\frac{\pi}{2} - \theta\right)\right)^2}}{\exp\left(\cos\left(\frac{\pi}{2} - \theta\right)\right) + \sqrt{\exp\left(\sin\left(\frac{\pi}{2} - \theta\right)\right)^2}} \quad (\text{dimensionless})$$

$$\Gamma_{v_m} := \frac{\exp\left(\cos\left(\frac{\pi}{2} - \frac{m \cdot \pi}{i}\right)\right) - \sqrt{\exp\left(\sin\left(\frac{\pi}{2} - \frac{m \cdot \pi}{i}\right)\right)^2}}{\exp\left(\cos\left(\frac{\pi}{2} - \frac{m \cdot \pi}{i}\right)\right) + \sqrt{\exp\left(\sin\left(\frac{\pi}{2} - \frac{m \cdot \pi}{i}\right)\right)^2}} \quad (\text{dimensionless})$$

Total Electric Field ( $E_{\text{vert}}$ ):

$$E_{\text{vert}}(\theta) := \left\{ \frac{k \cdot S \cdot f \cdot \mu_e \cdot I_0 \cdot \sin(\theta) \cdot e^{-j \cdot k \cdot r_{\text{ff}}}}{2 \cdot r_{\text{ff}}} \right\} \cdot \left\{ 1 + \Gamma_v(\theta) \cdot e^{-j \cdot 2 \cdot k \cdot h \cdot \cos(\theta)} \right\} \quad (\text{V/m})$$

$$E_{\text{vert}_m} := \left\| \left\{ \frac{k \cdot S \cdot f \cdot \mu_e \cdot I_0 \cdot \sin\left(\frac{m \cdot \pi}{i}\right) \cdot e^{-j \cdot k \cdot r_{\text{ff}}}}{2 \cdot r_{\text{ff}}} \right\} \cdot \left\{ 1 + \Gamma_{v_m} \cdot e^{-j \cdot 2 \cdot k \cdot h \cdot \cos\left(\frac{m \cdot \pi}{i}\right)} \right\} \right\| \quad (\text{V/m})$$

Radiation Intensity  $U(\theta)$ :

$$U(\theta) := \frac{r_{\text{ff}}^2}{2 \cdot \eta_0} \cdot (|E_{\text{vert}}(\theta)|)^2 \quad (\text{W / solid angle})$$

$$U_{\text{max}} := \frac{r_{\text{ff}}^2}{2 \cdot \eta_0} \cdot (|\max(E_{\text{vert}_m})|)^2 \quad (\text{W / solid angle})$$

$$U_{\text{max}} = 6.00502 \cdot 10^4 \quad (\text{W / solid angle})$$

Radiated Power  $P_{\text{rad}}$ :

$$P_{\text{rad}} := \int_0^\pi \int_0^\pi |U(\theta) \cdot \sin(\theta)| \, d\theta \, d\phi \quad (\text{W})$$

$$P_{\text{rad}} = 1.63918 \cdot 10^5 \quad (\text{W})$$

Directivity  $D_o$ :

$$D_o = \frac{4 \cdot \pi \cdot U_{\max}}{P_{\text{rad}}} \quad (\text{dimensionless})$$

$$D_o = 4.60361 \quad (\text{dimensionless})$$

Radiation Resistance ( $R_r$ ):

$$R_r := \frac{2 \cdot P_{\text{rad}}}{\left\{ |I_0| \right\}^2} \cdot N^2 \quad (\Omega)$$

$$R_r = 1.18021 \cdot 10^7 \quad (\Omega)$$

Surface Impedance of Conductor  $R_s$ :

$$R_s = \sqrt{\frac{\pi \cdot f \cdot \mu \epsilon}{\sigma c}} \quad (\Omega)$$

$$R_s = 0.09056 \quad (\Omega)$$

Ohmic Resistance  $R_{\text{ohmic}}$ :

$$R_{\text{ohmic}} := \frac{N \cdot a \cdot R_s}{b} \cdot (RR + 1) \quad (\Omega)$$

$$R_{\text{ohmic}} = 9.37266 \quad (\Omega)$$

Conduction-Dielectric Efficiency ( $\epsilon_{\text{cd}}$ ):

$$\epsilon_{\text{cd}} := \frac{R_r}{R_{\text{ohmic}} + R_r} \quad (\text{dimensionless})$$

$$\epsilon_{\text{cd}} = 1 \quad (\text{dimensionless})$$

Input Reactance ( $X_i$ ):

$$X_{\text{in}} = 2 \cdot \pi \cdot f \cdot a \cdot \mu \epsilon \cdot \left\{ \ln \left( 8 \cdot \frac{a}{b} \right) - 1.75 \right\} \quad (\Omega)$$

$$X_{\text{in}} = 4.3342 \cdot 10^5 \quad (\Omega)$$

Input Resistance ( $R_i$ ):

$$R_{\text{in}} := R_r + R_{\text{ohmic}} \quad (\Omega)$$

$$R_{\text{in}} = 1.18021 \cdot 10^7 \quad (\Omega)$$

Voltage Reflection Coefficient  $\Gamma$ :

$$\Gamma := \frac{Z_i - Z_0}{Z_i + Z_0} \quad (\text{dimensionless})$$

$$\Gamma = 0.64261 + 0.75809j \quad (\text{dimensionless})$$

Reflection Efficiency  $\epsilon_{rv}$ :

$$\epsilon_{rv} := 1 - (|\Gamma|)^2 \quad (\text{dimensionless})$$

$$\epsilon_{rv} = 0.01236 \quad (\text{dimensionless})$$

Gain  $G$ :

$$G := \epsilon_{rv} \cdot \omega d \cdot D_0 \quad (\text{dimensionless})$$

$$G_{db} := 10 \cdot \log(\epsilon_{rv} \cdot \omega d \cdot D_0) \quad (\text{dB})$$

$$G = 0.05689 \quad (\text{dimensionless})$$

$$G_{db} = -12.44948 \quad (\text{dB})$$

Maximum Effective Aperture ( $A_{em}$ ):

$$A_{em} := \frac{\epsilon_{rv} \cdot \omega d \cdot \lambda^2 \cdot D_0 \cdot (PLF)}{4 \cdot \pi} \quad (\text{m}^2)$$

$$A_{em} = 0.4521 \quad (\text{m}^2)$$

Bandwidth:

$$\text{Bandwidth} := \frac{c}{6 \cdot \pi \cdot a} \quad (\text{Hz})$$

$$\text{Bandwidth} = 1.06029 \cdot 10^8 \quad (\text{Hz})$$

Effective Isotropic Radiated Power (EIRP):

$$\text{EIRP} := \text{Prad} \cdot D_0 \quad (\text{W})$$

$$\text{EIRP} = 7.54613 \cdot 10^5 \quad (\text{W})$$

Maximum Effective Height ( $h_{em}$ ):

$$h_{em} := \sqrt{\frac{R_r \cdot A_{em}}{\eta_0}} \cdot 2 \quad (\text{m})$$

$$h_{em} = 2.37936 \cdot 10^2 \quad (\text{m})$$

Polarization Loss Factor (PLF):

$$\sigma_a := \begin{Bmatrix} 0 \\ 1 \\ 0 \end{Bmatrix} \quad (\text{dimensionless})$$

$$\sigma_w := \begin{Bmatrix} 0 \\ 1 \\ 0 \end{Bmatrix} \quad (\text{dimensionless})$$

$$\text{PLF} := \left( |\sigma_w \cdot \sigma_a| \right)^2 \quad (\text{dimensionless})$$

$$\text{PLF} = 1 \quad (\text{dimensionless})$$

CORE

For the purpose of this far-field radiation pattern, the small loop antenna axis is equivalent to the  $E_y = 0$  grid line. The pattern is symmetric when rotated in the  $(\phi)$  direction about the antenna's axis.

Small Vertical Loop with Ferrite Core  
Electric Over Real Ground

$$E_x(\theta) := |E_{\text{vert}}(\theta)| \cdot \cos(\theta)$$

$$E_y(\theta) := |E_{\text{vert}}(\theta)| \cdot \sin(\theta)$$

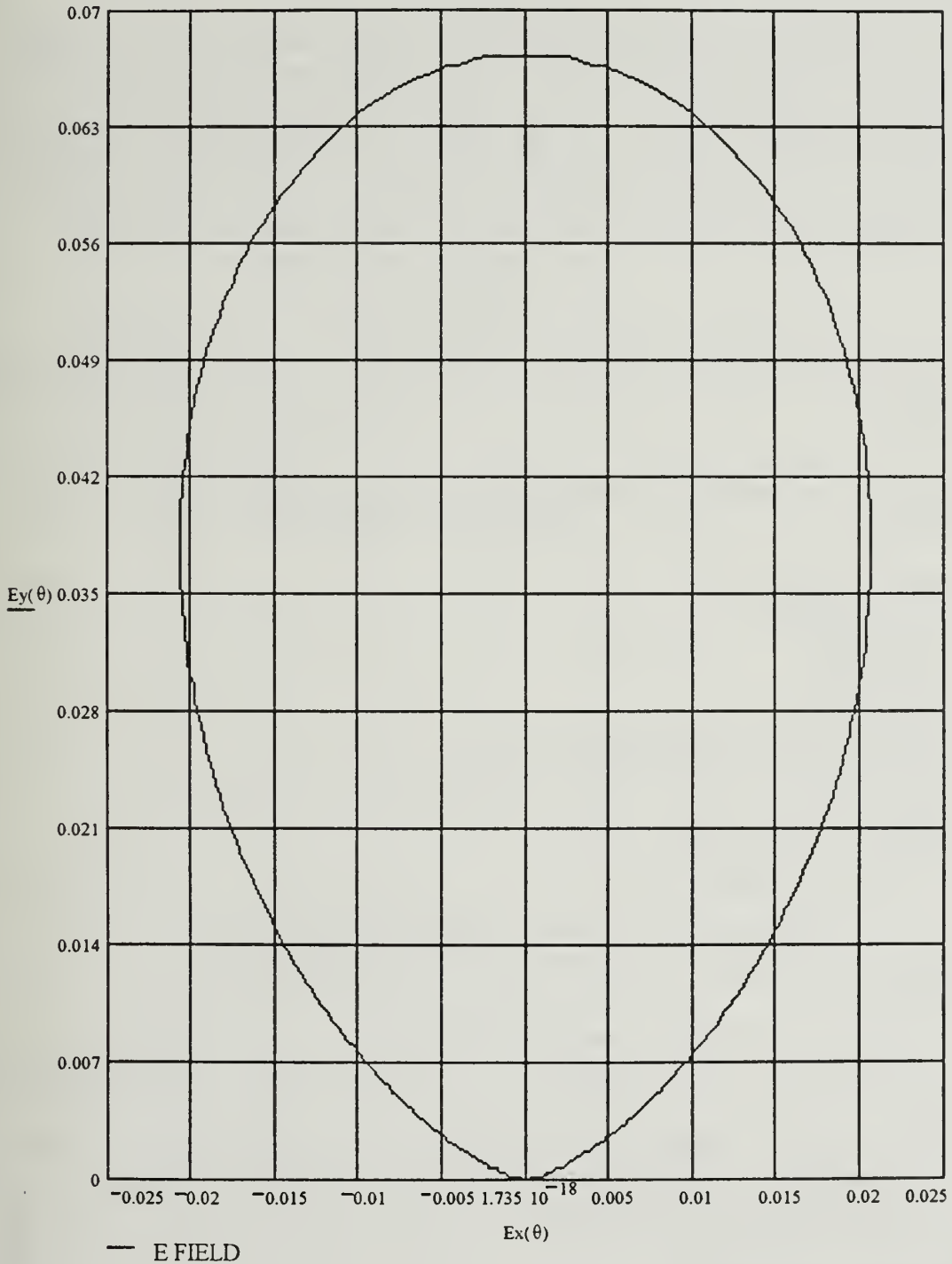

The large loop antenna is a coil of one or more turns whose radius (a) satisfies the following:

$$a \geq \lambda/6\pi \quad (\text{m})$$

where ( $\lambda$ ) is the wavelength of the frequency of interest. Large loops are not commonly used and are considered impractical if the radius exceeds one wavelength. Like the small loop, the efficiency of a transmitting large loop can be low. However, antenna efficiency can be improved by inserting a ferrite core in the loop or increasing the number of turns.

The large loop Mathcad applications will analyze two geometries: **free space and the horizontal loop**. Each application for a specific geometry will examine **air and ferrite cores**. Several antenna parameters, particularly those for loops in free space, can be calculated using more than one formula. Where this occurs, multiple results will be computed for comparison. Computations which are identical for all geometries will not be repeated. Computations with ferrite cores will use effective permeability ( $\mu_e$ ) in lieu of free space permeability ( $\mu_0$ ).

(Note:  $\lambda$  in a subscript indicates the dimension is in wavelengths. Mathcad equations cannot use symbolic subscripts. Therefore, the symbols will immediately follow the parameters in equations (i.e.,  $L\lambda$ ) in lieu of subscripts.)

The large loop antenna Mathcad application will compute the following parameters:

- S = Cross-Sectional Area
- C = Circumference
- k = Wavenumber
- $\lambda$  = Wavelength
- $D_0$  = Directivity
- E = Electric Field (No Ground Effects)
- $E_t$  = Electric Field (Total Field Including Ground Effects)
- U = Radiation Intensity
- $U_{\max}$  = Maximum Radiation Intensity
- $P_{\text{rad}}$  = Radiated Power
- $\Gamma_v$  = Vertical Reflection Coefficient (Ground Reflection)
- $\Gamma_h$  = Horizontal Reflection Coefficient (Ground Reflection)
- G = Gain
- EIRP = Effective Isotropic Radiated Power
- $A_{\text{em}}$  = Maximum Effective Aperture
- Bandwidth
- $\epsilon_r'$  = Ground Relative Complex Permittivity
- (Note: The subscript ' will be annotated as p in the application)
- $r_{\min}$  = Minimum Distance to Far-Field
- $R_{\text{ohmic}}$  = Ohmic Resistance
- $R_r$  = Radiation Resistance
- $R_s$  = Surface Impedance of Conductor



$\epsilon_{cd}$  = Conduction-Dielectric Efficiency  
 $\mu_e$  = Effective Ferrite Core Permeability  
 $h_{em}$  = Maximum Effective Height  
 CR = Core Length to Diameter Ratio

The following data must be input based on known or estimated data:

$h$  = Height of Antenna above ground  
 $a$  = Radius of Antenna  
 $b$  = Radius of Conductor  
 $N$  = Number of Turns  
 $\sigma_c$  = Conductivity of Loop  
 $R_p/R_o = RR$  = Ohmic Resistance from Proximity to Ohmic Skin Effect Ratio  
 $D_{demag}$  = Demagnetization Factor  
 $\mu_f$  = Permeability of Ferrite Core  
 $f$  = Frequency of Interest  
 $i$  = Number of Increments in Degrees for Far Field Radiation Pattern  
 $\sigma$  = Ground Conductivity  
 $\epsilon_r$  = Ground Relative Permittivity  
 $r_{ff}$  = Distance of Field Calculations  
 $I_o$  = Input Current at Antenna Terminals  
 $q$  = Loop Spacing  
 $cl$  = Core Length  
 $cd$  = Core Diameter  
 $Z_o$  = Characteristic Impedance

Enter input data here:

$a := .46$	(meters)	$\epsilon_r := 1$	(dimensionless)
$b := .05$	(meters)	$r_{ff} := 1 \cdot 10^5$	(meters)
$i := 360$	(degrees)	$RR := .15$	(dimensionless)
$h := .72$	(meters)	$cl := 1$	(meters)
$\sigma_c := 5.8 \cdot 10^7$	(mhos / m)	$Z_o := 50$	( $\Omega$ )
$q := .03$	(meters)	$D_{demag} := 4 \cdot 10^{-3}$	(dimensionless)
$\mu_f := 4000 \cdot (4 \cdot \pi \cdot 10^{-7})$	(Henrys / m)	$I_o := 1$	(amps)
$\sigma := 6 \cdot 10^7$	(mhos / m)	$f := 3.26 \cdot 10^8$	(Hz)
$\frac{q}{2 \cdot b} = 0.3$	(dimensionless)	$cd := .05$	(meters)
		$N := 1$	(dimensionless)

Calculate large loop antenna geometric parameters and define constants:

$c := 2.9979 \cdot 10^8$	(meters / sec)	$\eta_0 := 120 \cdot \pi$	( $\Omega$ )
$\lambda := \frac{c}{f}$	(meters / cycle)	$\epsilon_0 := \frac{1}{36 \cdot \pi} \cdot 10^{-9}$	(Farads / m)
$\lambda = 0.9196$	(meters / cycle)	$\mu_0 = 4 \cdot \pi \cdot 10^{-7}$	(H / m)
$S := \pi \cdot a^2$	( $m^2$ )	$D := 2 \cdot a$	(meters)
$S = 0.66476$	( $m^2$ )	$D = 0.92$	(meters)
$\frac{\lambda}{6 \cdot \pi} = 0.04879$	(meters)	$CR := \frac{cl}{cd}$	(dimensionless)
$C = 2 \cdot \pi \cdot a$	(meters)		
$C = 2.89027$	(meters)		

Calculate large loop antenna parameters in free space (air core):

Define angular offset  $\theta$   
from small loop axis:

Distance to Far-Field  $r_{min}$ :

		$r_0 := 1.6 \cdot \lambda$	(m)
$\theta := 0, \frac{2 \cdot \pi}{1} \dots 2 \cdot \pi$	(radians)	$r_1 := 5 \cdot D$	(m)
$\phi := 0, \left\{ \frac{2 \cdot \pi}{1} \right\} \dots 2 \cdot \pi$	(radians)	$r_2 := \frac{2 \cdot D^2}{\lambda}$	(m)
		$rmin := \max(r)$	(m)
		$rmin = 4.6$	(m)

Wavenumber k:

$$k := \frac{2 \cdot \pi}{\lambda} \quad (m^{-1})$$

$$k = 6.83251 \quad (m^{-1})$$

$$m = 0..i \quad (\text{increments})$$

$$E(\theta) := \left\{ \frac{2 \cdot \pi \cdot f \cdot a \cdot \mu_0 \cdot I_0}{2 \cdot rff} \right\} \cdot e^{-(j \cdot k \cdot rff)} \cdot J_1(k \cdot a \cdot \sin(\theta)) \quad (\text{V/m})$$

$$E_{1_m} := \left\{ \frac{2 \cdot \pi \cdot f \cdot a \cdot \mu_0 \cdot I_0}{2 \cdot rff} \right\} \cdot e^{-(j \cdot k \cdot rff)} \cdot J_1 \left\{ k \cdot a \cdot \sin \left( \frac{m \cdot \pi}{i} \right) \right\} \quad (\text{V/m})$$

Radiation Intensity U(θ):

$$U(\theta) := \frac{rff^2}{2 \cdot \eta_0} \cdot (|E(\theta)|)^2 \quad (\text{W/solid angle})$$

$$U_{1_m} = \frac{rff^2}{2 \cdot \eta_0} \cdot \left\{ |E_{1_m}| \right\}^2 \quad (\text{W/solid angle})$$

$$U_{\max} := \max(U_1) \quad (\text{W/solid angle})$$

$$U_{\max} = 1.57377 \cdot 10^2 \quad (\text{W/solid angle})$$

Radiated Power P<sub>rad</sub>:

$$Prad := \int_0^{2 \cdot \pi} \int_0^{\pi} U(\theta) \cdot \sin(\theta) \, d\theta \, d\phi \quad (\text{W})$$

$$Prad = 1.09949 \cdot 10^3 \quad (\text{W})$$

Directivity  $D_o$ :

$$D_o := .682 \cdot \left\{ \frac{C}{\lambda} \right\} \quad (\text{dimensionless})$$

$$D_o = 2.1435 \quad (\text{dimensionless})$$

$$D_{o2} := \frac{4 \cdot \pi \cdot U_{\max}}{\text{Prad}} \quad (\text{dimensionless})$$

$$D_{o2} = 1.79871 \quad (\text{dimensionless})$$

Radiation Resistance ( $R_r$ ):

$$R_r := 60 \cdot \pi^2 \cdot \frac{C}{\lambda} \cdot N^2 \quad (\Omega)$$

$$R_r = 1.86118 \cdot 10^3 \quad (\Omega)$$

$$R_{r2} := \frac{2 \cdot \text{Prad} \cdot N^2}{\left( |I_o| \right)^2} \quad (\Omega)$$

$$R_{r2} = 2.19898 \cdot 10^3 \quad (\Omega)$$

Surface Impedance of Conductor  $R_s$ :

$$R_s := \sqrt{\frac{\pi \cdot f \cdot \mu_0}{\sigma c}} \quad (\Omega)$$

$$R_s = 4.71058 \cdot 10^{-3} \quad (\Omega)$$

$$R_{ohmic} := \frac{N \cdot a \cdot R_s}{b} \cdot (RR + 1) \quad (\Omega)$$

$$R_{ohmic} = 0.04984 \quad (\Omega)$$

Conduction-Dielectric Efficiency ( $\epsilon_{cd}$ ):

$$\epsilon_{cd} := \frac{R_r}{R_{ohmic} + R_r} \quad (\text{dimensionless})$$

$$\epsilon_{cd} = 0.99997 \quad (\text{dimensionless})$$

Gain G:

$$G := \epsilon_{cd} \cdot D_o \quad (\text{dimensionless})$$

$$G_{db} := 10 \cdot \log(\epsilon_{cd} \cdot D_o) \quad (\text{dB})$$

$$G = 2.14344 \quad (\text{dimensionless})$$

$$G_{db} = 3.31111 \quad (\text{dB})$$

Maximum Effective Aperture ( $A_{em}$ ):

$$A_{em} = .0543 \cdot (\lambda \cdot C) \quad (\text{m}^2)$$

$$A_{em} = 0.14432 \quad (\text{m}^2)$$

$$A_{em2} := \frac{\epsilon_{cd} \cdot \lambda^2 \cdot D_o}{4 \cdot \pi} \quad (\text{m}^2)$$

$$A_{em2} = 0.14424 \quad (\text{m}^2)$$

Effective Isotropic Radiated Power (EIRP):

$$\text{EIRP} := \text{Prad} \cdot \text{Do} \quad (\text{W})$$

$$\text{EIRP} = 2.35675 \cdot 10^3 \quad (\text{W})$$

Bandwidth:

$$\text{Bandwidth} := \frac{c}{a} \cdot \left\{ 1 - \frac{1}{6 \cdot \pi} \right\} \quad (\text{Hz})$$

$$\text{Bandwidth} = 6.17143 \cdot 10^8 \quad (\text{Hz})$$

Maximum Effective Height ( $h_{em}$ ):

$$\text{hem} := \sqrt{\frac{\text{Rr} \cdot \text{Aem}}{\eta_0}} \cdot 2 \quad (\text{m})$$

$$\text{hem} = 1.68821 \quad (\text{m})$$

$$\text{hem2} := \sqrt{\frac{\text{Rr} \cdot \text{Aem2}}{\eta_0}} \cdot 2 \quad (\text{m})$$

$$\text{hem2} = 1.68775 \quad (\text{m})$$

For the purpose of this far-field radiation pattern, the large loop antenna axis is equivalent to the  $E_y = 0$  grid line. The pattern is symmetric when rotated in the  $(\phi)$  direction about the antenna's axis.

Electric Field Without Ground Effects

$$E_x(\theta) := |E(\theta)| \cdot \cos(\theta)$$

$$E_y(\theta) := |E(\theta)| \cdot \sin(\theta)$$

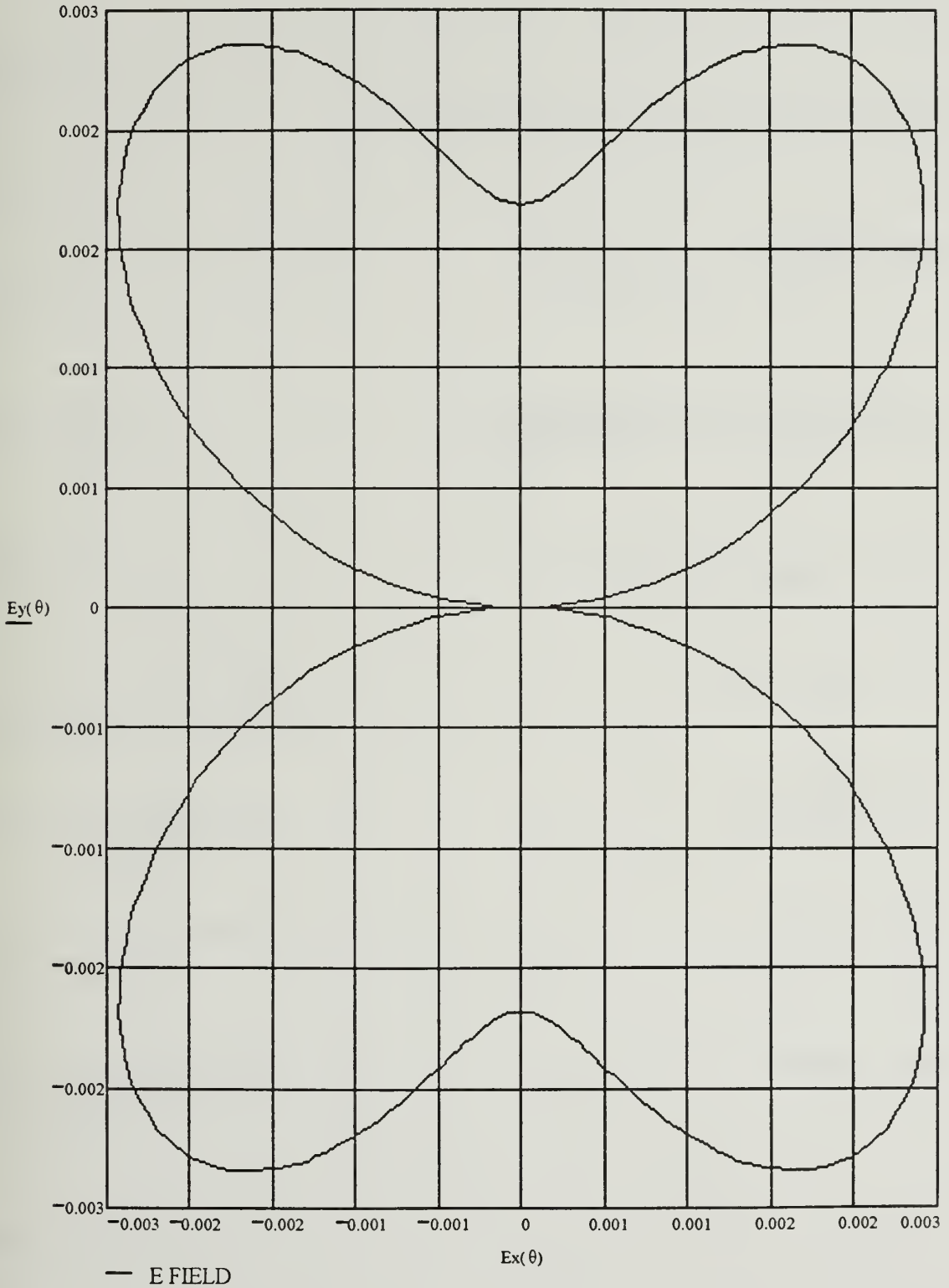



Effective Permeability ( $\mu_e$ ):

$$\mu_e = \frac{\mu^f}{1 + D_{\text{demag}} \cdot (\mu^f - 1)} \quad (\text{H/m})$$

$$\mu_e = 5.04663 \cdot 10^{-3} \quad (\text{H/m})$$

Electric Field Without Ground Effects  $E(\theta)$ :

$$E(\theta) = \left\{ \frac{2 \cdot \pi \cdot f \cdot a \cdot \mu_e \cdot I_0}{2 \cdot r_{\text{ff}}} \right\} \cdot e^{-(j \cdot k \cdot r_{\text{ff}})} \cdot J_1(k \cdot a \cdot \sin(\theta)) \quad (\text{V/m})$$

$$E_{1_m} := \left\{ \frac{2 \cdot \pi \cdot f \cdot a \cdot \mu_e \cdot I_0}{2 \cdot r_{\text{ff}}} \right\} \cdot e^{-(j \cdot k \cdot r_{\text{ff}})} \cdot J_1 \left( k \cdot a \cdot \sin \left( \frac{m \cdot \pi}{i} \right) \right) \quad (\text{V/m})$$

Radiation Intensity  $U(\theta)$ :

$$U(\theta) := \frac{r_{\text{ff}}^2}{2 \cdot \eta_0} \cdot (|E(\theta)|)^2 \quad (\text{W / solid angle})$$

$$U_{1_m} = \frac{r_{\text{ff}}^2}{2 \cdot \eta_0} \cdot (|E_{1_m}|)^2 \quad (\text{W / solid angle})$$

$$U_{\text{max}} := \max(U_1) \quad (\text{W / solid angle})$$

$$U_{\text{max}} = 2.5382 \cdot 10^9 \quad (\text{W / solid angle})$$

Radiated Power P<sub>rad</sub>:

$$Prad := \int_0^{2\pi} \int_0^{\pi} U(\theta) \cdot \sin(\theta) \, d\theta \, d\phi \quad (W)$$

$$Prad = 1.77327 \cdot 10^{10} \quad (W)$$

Directivity D<sub>o</sub>:

$$Do := .682 \cdot \frac{C}{\lambda} \quad (\text{dimensionless})$$

$$Do = 2.1435 \quad (\text{dimensionless})$$

$$Do2 := \frac{4 \cdot \pi \cdot U_{max}}{Prad} \quad (\text{dimensionless})$$

$$Do2 = 1.79871 \quad (\text{dimensionless})$$

Radiation Resistance (R<sub>r</sub>):

$$Rr := \pi^2 \cdot 60 \cdot \frac{C}{\lambda} \cdot \left( \frac{\mu e}{\mu_0} \right)^2 \cdot N^2 \quad (\Omega)$$

$$Rr = 3.00174 \cdot 10^{10} \quad (\Omega)$$

$$Rr2 := \frac{2 \cdot Prad}{\left( |I_0| \right)^2} \cdot N^2 \quad (\Omega)$$

$$Rr2 = 3.54654 \cdot 10^{10} \quad (\Omega)$$

Surface Impedance of Conductor  $R_s$ :

$$R_s := \sqrt{\frac{\pi f \mu \epsilon}{\sigma}} \quad (\Omega)$$

$$R_s = 0.29852 \quad (\Omega)$$

Ohmic Resistance  $R_{ohmic}$ :

$$R_{ohmic} := \frac{N \cdot a \cdot R_s}{b} \cdot (RR + 1) \quad (\Omega)$$

$$R_{ohmic} = 3.15832 \quad (\Omega)$$

Conduction-Dielectric Efficiency ( $\epsilon_{cd}$ ):

$$\epsilon_{cd} := \frac{R_r}{R_{ohmic} + R_r} \quad (\text{dimensionless})$$

$$\epsilon_{cd} = 1 \quad (\text{dimensionless})$$

Gain  $G$ :

$$G := \epsilon_{cd} \cdot D_o \quad (\text{dimensionless})$$

$$G_{db} = 10 \cdot \log(\epsilon_{cd} \cdot D_o) \quad (\text{dB})$$

$$G = 2.1435 \quad (\text{dimensionless})$$

$$G_{db} = 3.31123 \quad (\text{dB})$$

Maximum Effective Aperture ( $A_{em}$ ):

$$A_{em} := \frac{\sigma \cdot \lambda^2 \cdot D_o}{4 \cdot \pi} \quad (m^2)$$

$$A_{em} = 0.14425 \quad (m^2)$$

Effective Isotropic Radiated Power (EIRP):

$$EIRP := Prad \cdot D_o \quad (W)$$

$$EIRP = 3.801 \cdot 10^{10} \quad (W)$$

Bandwidth:

$$\text{Bandwidth} := \frac{c}{a} \left\{ 1 - \frac{1}{6 \cdot \pi} \right\} \quad (Hz)$$

$$\text{Bandwidth} = 6.17143 \cdot 10^8 \quad (Hz)$$

Maximum Effective Height ( $h_{em}$ ):

$$h_{em} = \sqrt{\frac{Rr \cdot A_{em}}{\eta_0}} \cdot 2 \quad (m)$$

$$h_{em} = 6.77808 \cdot 10^3 \quad (m)$$

LARGE LOOP ANTENNA FAR FIELD PATTERN IN FREE SPACE WITH FERRITE CORE

For the purpose of this far-field radiation pattern, the large loop antenna axis is equivalent to the  $E_y = 0$  grid line. The pattern is symmetric when rotated in the  $(\phi)$  direction about the antenna's axis.

Electric Field Without Ground Effects

$$E_x(\theta) := |E(\theta)| \cdot \cos(\theta)$$

$$E_y(\theta) := |E(\theta)| \cdot \sin(\theta)$$

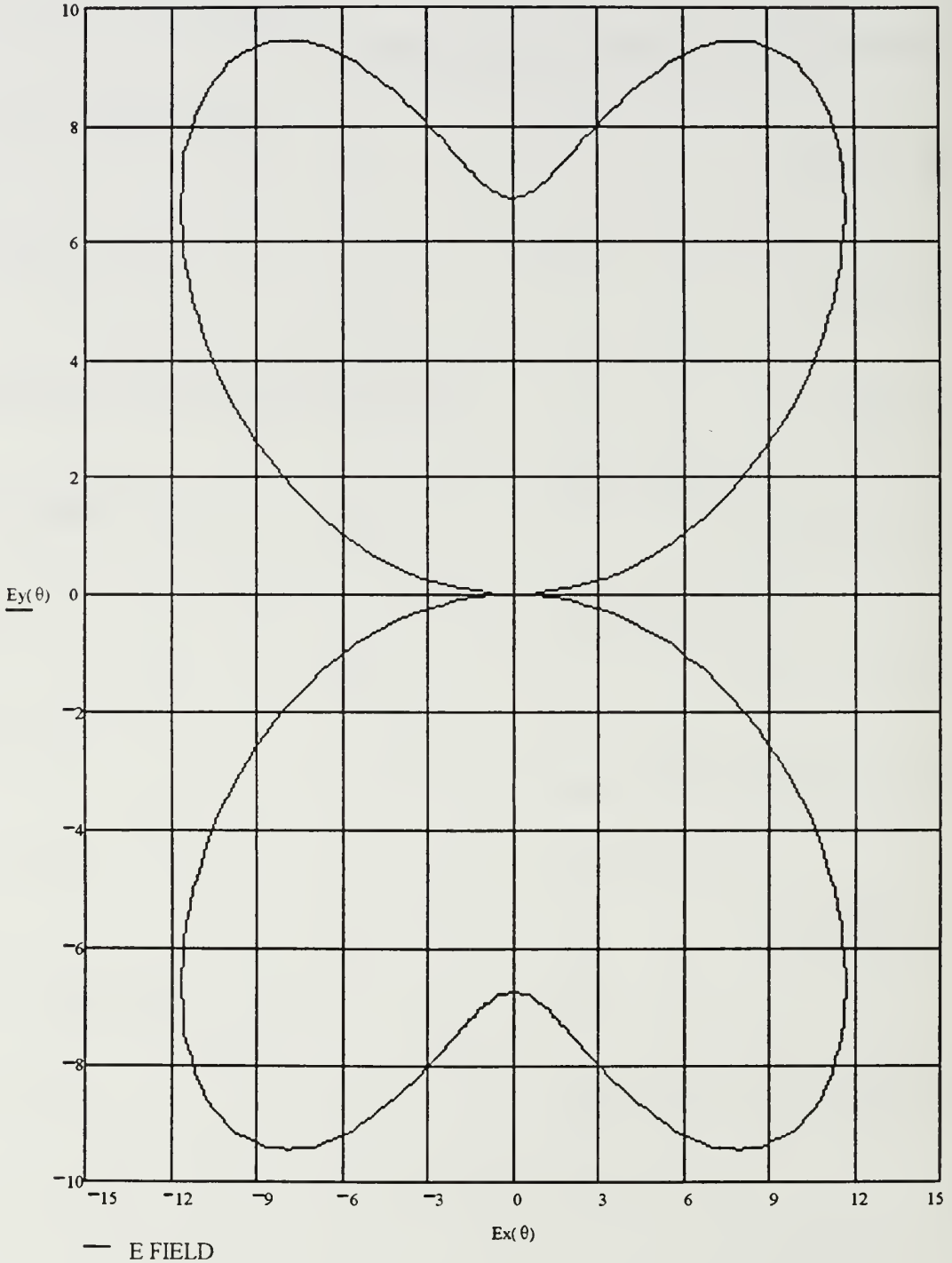

Calculate large horizontal loop antenna parameters over ground (air core):

Define angular offset  $\theta$   
from small loop axis:

$$\theta := -\frac{\pi}{2}, -\frac{\pi}{2} + \frac{\pi}{i} \dots \frac{\pi}{2} \quad (\text{radians})$$

$$\phi := 0, \left\{ \frac{2 \cdot \pi}{i} \right\} \dots 2 \cdot \pi \quad (\text{radians})$$

Relative Complex Permittivity ( $\epsilon_r$ ):

$$\epsilon_r := \epsilon - j \cdot \frac{\sigma}{2 \cdot \pi \cdot f \cdot \epsilon_0} \quad (\text{dimensionless})$$

$$\epsilon_r = 1 - 3.31288 \cdot 10^9 j \quad (\text{dimensionless})$$

Horizontal Reflection Coefficient ( $\Gamma_h$ ):

$$m = 0 \dots \frac{i}{2} \quad (\text{increments})$$

$$\Gamma_h(\theta) := \frac{\cos(\theta) - \sqrt{\epsilon_r - \sin(\theta)^2}}{\cos(\theta) + \sqrt{\epsilon_r - \sin(\theta)^2}} \quad (\text{dimensionless})$$

$$\Gamma_{h_m} := \frac{\cos\left(\frac{m \cdot \pi}{i}\right) - \sqrt{\epsilon_r - \sin\left(\frac{m \cdot \pi}{i}\right)^2}}{\cos\left(\frac{m \cdot \pi}{i}\right) + \sqrt{\epsilon_r - \sin\left(\frac{m \cdot \pi}{i}\right)^2}} \quad (\text{dimensionless})$$

Total Electric Field (Ethor):

$$\text{Ethor}(\theta) := \left\{ \frac{2 \cdot \pi \cdot f \cdot a \cdot \mu_0 \cdot I_0}{2 \cdot r_{ff}} \right\} \cdot e^{-(j \cdot k \cdot r_{ff})} \cdot J_1(k \cdot a \cdot \sin(\theta)) \cdot \left\{ 1 - \Gamma_h(\theta) \cdot e^{-j \cdot 2 \cdot k \cdot h \cdot \cos(\theta)} \right\} \quad (\text{V/m})$$

$$\text{Ethor1}_m := \left\{ \frac{2 \cdot \pi \cdot f \cdot a \cdot \mu_0 \cdot I_0}{2 \cdot r_{ff}} \right\} \cdot e^{-(j \cdot k \cdot r_{ff})} \cdot \left\{ J_1 \left( k \cdot a \cdot \sin \left( \frac{m \cdot \pi}{i} \right) \right) \right\} \cdot \left\{ 1 - \Gamma_{h1}_m \cdot e^{-j \cdot 2 \cdot k \cdot h \cdot \cos \left( \frac{m \cdot \pi}{i} \right)} \right\} \quad (\text{V/m})$$

Radiation Intensity U(θ):

$$U(\theta) := \frac{r_{ff}^2}{2 \cdot \eta_0} \cdot (|\text{Ethor}(\theta)|)^2 \quad (\text{W/solid angle})$$

$$U_{\max} := \frac{r_{ff}^2}{2 \cdot \eta_0} \cdot (|\max(\text{Ethor1})|)^2 \quad (\text{W/solid angle})$$

$$U_{\max} = 7.03652 \cdot 10^2 \quad (\text{W/solid angle})$$

Radiated Power P<sub>rad</sub>:

$$\text{Prad} := \int_0^{2 \cdot \pi} \int_0^{\frac{\pi}{2}} |U(\theta) \cdot \sin(\theta)| \, d\theta \, d\phi \quad (\text{W})$$

$$\text{Prad} = 1.13445 \cdot 10^3 \quad (\text{W})$$

Directivity D<sub>o</sub>:

$$D_o := \frac{4 \cdot \pi \cdot U_{\max}}{\text{Prad}} \quad (\text{dimensionless})$$

$$D_o = 7.79439 \quad (\text{dimensionless})$$



Radiation Resistance (R<sub>r</sub>):

$$R_r := \frac{2 \cdot \text{Prad}}{\left(|I_0|\right)^2} \cdot N^2 \quad (\Omega)$$

$$R_r = 2.2689 \cdot 10^3 \quad (\Omega)$$

Bandwidth:

$$\text{Bandwidth} := \frac{c}{a} \cdot \left(1 - \frac{1}{6 \cdot \pi}\right) \quad (\text{Hz})$$

$$\text{Bandwidth} = 6.17143 \cdot 10^8 \quad (\text{Hz})$$

Surface Impedance of Conductor R<sub>s</sub>:

$$R_s := \sqrt{\frac{\pi \cdot f \cdot \mu_0}{\sigma c}} \quad (\Omega)$$

$$R_s = 4.71058 \cdot 10^{-3} \quad (\Omega)$$

Ohmic Resistance R<sub>ohmic</sub>:

$$R_{ohmic} := \frac{N \cdot a \cdot R_s}{b} \cdot (RR + 1) \quad (\Omega)$$

$$R_{ohmic} = 0.04984 \quad (\Omega)$$

Conduction-Dielectric Efficiency (ε<sub>cd</sub>):

$$\epsilon_{cd} := \frac{R_r}{R_{ohmic} + R_r} \quad (\text{dimensionless})$$

$$\epsilon_{cd} = 0.99998 \quad (\text{dimensionless})$$

Maximum Effective Aperture (A<sub>em</sub>):

$$A_{em} := \frac{\epsilon c d \lambda^2 \cdot Do}{4 \cdot \pi} \quad (m^2)$$

$$A_{em} = 0.52452 \quad (m^2)$$

Gain G:

$$G := \epsilon c d \cdot Do \quad (\text{dimensionless})$$

$$G_{db} := 10 \cdot \log(\epsilon c d \cdot Do) \quad (dB)$$

$$G = 7.79422 \quad (\text{dimensionless})$$

$$G_{db} = 8.91773 \quad (dB)$$

Maximum Effective Height (h<sub>em</sub>):

$$h_{em} = \sqrt{\frac{R_r \cdot A_{em}}{\eta_0}} \cdot 2 \quad (m)$$

$$h_{em} = 3.55347 \quad (m)$$

Effective Isotropic Radiated Power (EIRP):

$$EIRP := Prad \cdot Do \quad (W)$$

$$EIRP = 8.84235 \cdot 10^3 \quad (W)$$

For the purpose of this far-field radiation pattern, the large loop antenna axis is equivalent to the  $E_x = 0$  grid line. The pattern is symmetric when rotated in the  $(\phi)$  direction about the antenna's axis.

Large Horizontal Loop with Air Core Electric  
Over Real Ground

$$E_x(\theta) = |E_{\theta}(\theta)| \cdot \cos\left(\theta + \frac{\pi}{2}\right)$$

$$E_y(\theta) = |E_{\theta}(\theta)| \cdot \sin\left(\theta + \frac{\pi}{2}\right)$$

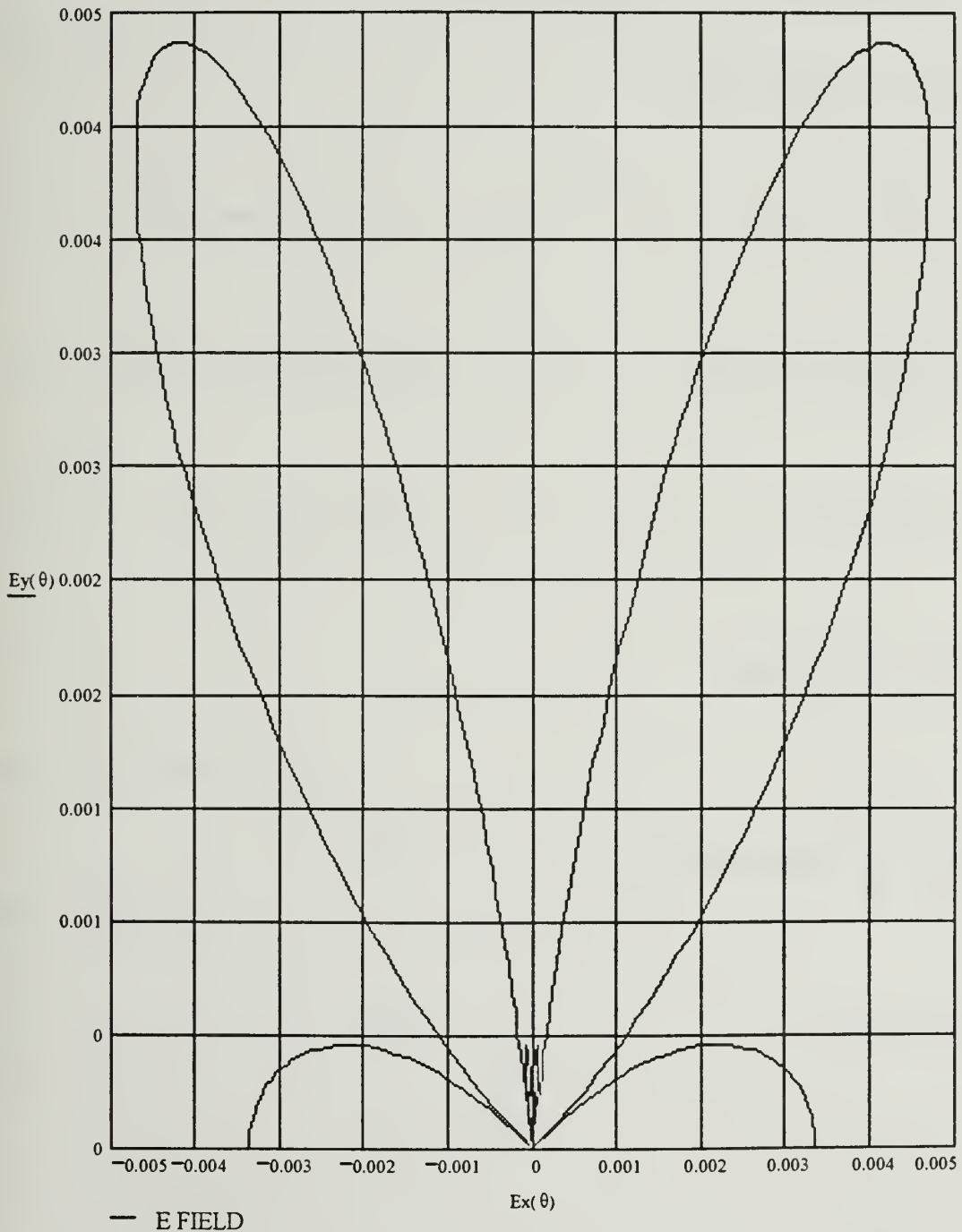

Calculate large horizontal loop antenna parameters over ground (ferrite core) :

Total Electric Field (Ethor) :

$$E_{\text{thor}}(\theta) := \left\{ \frac{2 \cdot \pi \cdot f \cdot a \cdot \mu \cdot I_0}{2 \cdot r_{\text{ff}}} \right\} \cdot e^{-(j \cdot k \cdot r_{\text{ff}})} \cdot J_1(k \cdot a \cdot \sin(\theta)) \cdot \left\{ 1 - \Gamma_{\text{h}}(\theta) \cdot e^{-j \cdot 2 \cdot k \cdot h \cdot \cos(\theta)} \right\} \quad (\text{V/m})$$

$$E_{\text{thor}1_m} = \left\{ \frac{2 \cdot \pi \cdot f \cdot a \cdot \mu \cdot I_0}{2 \cdot r_{\text{ff}}} \right\} \cdot e^{-(j \cdot k \cdot r_{\text{ff}})} \cdot \left\{ J_1 \left( k \cdot a \cdot \sin \left( \frac{m \cdot \pi}{i} \right) \right) \right\} \cdot \left\{ 1 - \Gamma_{\text{h}1_m} \cdot e^{-j \cdot 2 \cdot k \cdot h \cdot \cos \left( \frac{m \cdot \pi}{i} \right)} \right\} \quad (\text{V/m})$$

Radiation Intensity U(θ) :

$$U(\theta) := \frac{r_{\text{ff}}^2}{2 \cdot \eta_0} \cdot (|E_{\text{thor}}(\theta)|)^2 \quad (\text{W / solid angle})$$

$$U_{\text{max}} = \frac{r_{\text{ff}}^2}{2 \cdot \eta_0} \cdot (|\text{max}(E_{\text{thor}1})|)^2 \quad (\text{W / solid angle})$$

$$U_{\text{max}} = 1.13486 \cdot 10^{10} \quad (\text{W / solid angle})$$

Radiated Power P<sub>rad</sub> :

$$P_{\text{rad}} := \int_0^9 \int_0^{\frac{\pi}{2}} |U(\theta) \cdot \sin(\theta)| \, d\theta \, d\phi \quad (\text{W})$$

$$P_{\text{rad}} = 1.82966 \cdot 10^{10} \quad (\text{W})$$

Directivity  $D_o$ :

$$D_o := \frac{4 \cdot \pi \cdot U_{\max}}{P_{\text{rad}}} \quad (\text{dimensionless})$$

$$D_o = 7.79439 \quad (\text{dimensionless})$$

Radiation Resistance ( $R_r$ ):

$$R_r := \frac{2 \cdot P_{\text{rad}}}{(|I_o|)^2} \cdot N^2 \quad (\Omega)$$

$$R_r = 3.65931 \cdot 10^{10} \quad (\Omega)$$

Surface Impedance of Conductor  $R_s$ :

$$R_s := \sqrt{\frac{\pi \cdot f \cdot \mu \epsilon}{\sigma}} \quad (\Omega)$$

$$R_s = 0.29852 \quad (\Omega)$$

Ohmic Resistance  $R_{\text{ohmic}}$ :

$$R_{\text{ohmic}} := \frac{N \cdot a \cdot R_s}{b} \cdot (RR + 1) \quad (\Omega)$$

$$R_{\text{ohmic}} = 3.15832 \quad (\Omega)$$

Conduction-Dielectric Efficiency ( $\epsilon_{cd}$ ):

$$\epsilon_{cd} := \frac{R_r}{R_{ohmic} + R_r} \quad (\text{dimensionless})$$

$$\epsilon_{cd} = 1 \quad (\text{dimensionless})$$

Gain G:

$$G := \epsilon_{cd} D_o \quad (\text{dimensionless})$$

$$G_{db} := 10 \cdot \log(\epsilon_{cd} \cdot D_o) \quad (\text{dB})$$

$$G = 7.79439 \quad (\text{dimensionless})$$

$$G_{db} = 8.91782 \quad (\text{dB})$$

Maximum Effective Aperture ( $A_{em}$ ):

$$A_{em} := \frac{\epsilon_{cd} \lambda^2 D_o}{4 \pi} \quad (\text{m}^2)$$

$$A_{em} = 0.52453 \quad (\text{m}^2)$$

Effective Isotropic Radiated Power (EIRP):

$$\text{EIRP} := \text{Prad} D_o \quad (\text{W})$$

$$\text{EIRP} = 1.42611 \cdot 10^{11} \quad (\text{W})$$

Bandwidth:

$$\text{Bandwidth} := \frac{c}{a} \cdot \left\{ 1 - \frac{1}{6 \cdot \pi} \right\} \quad (\text{Hz})$$

$$\text{Bandwidth} = 6.17143 \cdot 10^8 \quad (\text{Hz})$$

Maximum Effective Height ( $h_{em}$ ):

$$h_{em} := \sqrt{\frac{Rr \cdot A_{cm}}{\eta_0}} \cdot 2 \quad (\text{m})$$

$$h_{em} = 1.42709 \cdot 10^4 \quad (\text{m})$$



LARGE HORIZONTAL LOOP ANTENNA FAR FIELD PATTERN ABOVE GROUND WITH FERRITE CORE

For the purpose of this far-field radiation pattern, the large loop antenna axis is equivalent to the  $E_x = 0$  grid line. The pattern is symmetric when rotated in the  $(\phi)$  direction about the antenna's axis.

Large Horizontal Loop with Ferrite Core  
Electric Over Real Ground

$$E_x(\theta) := |E_{\theta}(\theta)| \cdot \cos\left\{\theta + \frac{\pi}{2}\right\} \qquad E_y(\theta) := |E_{\theta}(\theta)| \cdot \sin\left\{\theta + \frac{\pi}{2}\right\}$$

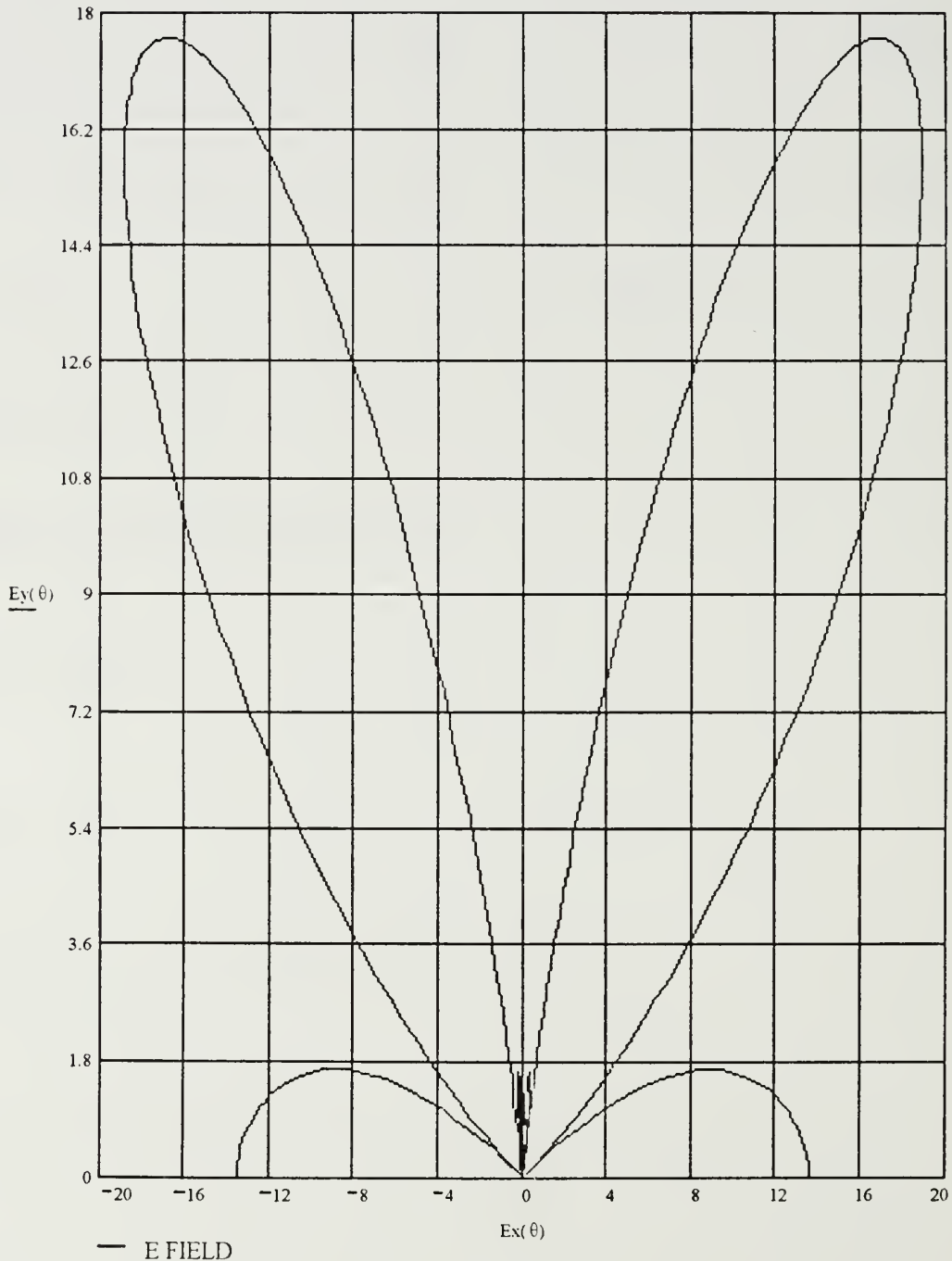

A bedspring (or curtain) antenna is a two dimensional array of identical horizontal dipoles. The vertical stacks of dipoles are referred to as bays. A bedspring antenna is built from two or more bays. Bedspring assemblies are normally designed for high frequency (3 - 30 MHz) operations. The beam maximum can be steered in either the azimuthal or vertical directions by adjusting the phase of the element feed currents. Bedspring antenna Mathcad applications assume that all elements lie in the y-z plane, that all element excitation currents have identical maximum amplitude, that there are only 2 dB of losses associated with the antenna, and that a perfect reflector screen is located in the -x half space.

(Note: Mathcad equations cannot use symbolic subscripts. Therefore, symbols like  $\lambda$  will immediately follow the parameter in equations in lieu of subscripts. )

The bedspring antenna Mathcad application will compute the following parameters:

D = Maximum Physical Dimension of the Array  
k = Wavenumber  
 $\lambda$  = Wavelength  
 $D_o$  = Directivity  
 $E_{\theta 1}$  = Electric Field ( $\theta$ ) Component for an Individual Bay  
 $E_{\phi 1}$  = Electric Field ( $\phi$ ) Component for an Individual Bay  
 $S_x$  = Array Factor for Perfect Image Reflector  
 $S_y$  = Array Factor for Multiple Bays  
A, B = Electric Field Coefficients  
 $E_{\theta t}$  = Electric Field ( $\theta$ ) Component (Including Ground Effects)  
 $E_{\phi t}$  = Electric Field ( $\phi$ ) Component (Including Ground Effects)  
U = Radiation Intensity  
 $U_{max}$  = Maximum Radiation Intensity  
 $P_{rad}$  = Radiated Power  
 $\Gamma_v$  = Vertical Reflection Coefficient (Ground Reflection)  
 $\Gamma_h$  = Horizontal Reflection Coefficient (Ground Reflection)  
G = Gain  
EIRP = Effective Isotropic Radiated Power  
 $A_{em}$  = Maximum Effective Aperture  
BW = Bandwidth  
 $\epsilon_r'$  = Ground Relative Complex Permittivity  
(Note: The subscript ' will be annotated as p in the application)  
 $r_{min}$  = Minimum Distance to Far-Field  
 $R_r$  = Radiation Resistance  
 $h_{em}$  = Maximum Effective Height  
 $|I_o|$  = Magnitude of Antenna Feed Current  
 $E_{x,y,z}$  = Electric Field Spatial Components  
 $\sigma_a$  = Antenna Unit Polarization Vector  
 $f_{high}$  = Upper Operating Frequency  
 $f_{low}$  = Lower Operating Frequency

PLF = Polarization Loss Factor  
 $\sigma_a$  = Antenna Unit Polarization Vector  
 $\theta_p$  = Coaltitude (Deflection Angle from +z Axis) for Polarization Loss  
 $\phi_p$  = Azimuth Angle for Polarization Loss

The following data must be input based on known or estimated data:

M = Number of Elements per Bay  
N = Number of Bays  
 $Z_i$  = Height of ith Element Above Ground  
 $Z_i - Z_{i-1}$  = Vertical Spacing of the ith Element  
 $Y_i$  = Horizontal Position (Center of Dipole) of  $i^{\text{th}}$  Bay  
 $Y_i - Y_{i-1}$  = Horizontal Spacing of the  $i^{\text{th}}$  Bay  
 $X_1$  = Reflector Position  
l = Half-Length of Each Element  
f = Frequency of Interest  
i = Number of Increments for Far Field Radiation Patterns  
(Note: Due to Mathcad restrictions on matrix size,  $i \leq 125$ )  
 $\sigma$  = Ground Conductivity  
 $\epsilon_r$  = Ground Relative Permittivity  
 $r_{ff}$  = Distance of Field Calculations  
 $I_m$  = Input Current at Element Terminals  
 $\theta_g$  = Coaltitude (Deflection Angle from +z Axis) for Azimuth Plot  
 $\phi_g$  = Azimuth Angle for Elevation Plot  
 $C_i$  = Relative Current Amplitude of  $i^{\text{th}}$  Element  
 $\theta_o$  = Vertical Scan Angle (Coaltitude)  
 $\phi_o$  = Azimuthal Scan Angle  
(x, y, z) = Coordinates for Unit Polarization Vector  
 $\sigma_w$  = Incoming Wave Unit Polarization Vector

---

Enter input data here:

M := 4 (elements)

f :=  $10 \cdot 10^6$  (Hz)

N := 2 (bays)

$\epsilon$  := 10 (dimensionless)

i = 90 (increments)

rff =  $1 \cdot 10^5$  (meters)

Z :=  $\begin{bmatrix} 55 & 55 \\ 42 & 42 \\ 29 & 29 \\ 16 & 16 \end{bmatrix}$  (m)

Im := 1 (amps)

$\sigma$  := .01 (mhos / m)

Y =  $\begin{bmatrix} 0 & 26 \\ 0 & 26 \\ 0 & 26 \\ 0 & 26 \end{bmatrix}$  (m)

X1 := 7 (m)

l = 11 (m)

C :=  $\begin{bmatrix} 1 & 1 \\ 1 & 1 \\ 1 & 1 \\ 1 & 1 \end{bmatrix}$  (amps)

$\theta_0 := \frac{\pi}{2}$  (radians)

$\phi_0 := 0$  (radians)

$\sigma_w = \begin{bmatrix} \frac{1}{\sqrt{2}} \\ \sqrt{2} \\ \frac{1}{\sqrt{2}} \\ 0 \end{bmatrix}$  (dimensionless)

x := 1000 (m)

y = 50 (m)

z := 50 (m)

---

Calculate bedspring antenna geometric parameters and define constants:

$$c = 2.9979 \cdot 10^8 \quad (\text{meters/sec})$$

$$\eta_0 = 120 \cdot \pi \quad (\Omega)$$

$$\lambda := \frac{c}{f} \quad (\text{meters/cycle})$$

$$\epsilon_0 = \frac{1}{36 \cdot \pi} 10^{-9} \quad (\text{Farads/m})$$

$$\lambda = 29.979 \quad (\text{meters/cycle})$$

$$\mu_0 := 4 \pi 10^{-7} \quad (\text{H/m})$$

$$D = \sqrt{\{Y_{0,N-1}\}^2 + \{Z_{0,0}\}^2} \quad (\text{m})$$

$$D = 60.83584 \quad (\text{m})$$

Calculate bedspring antenna parameters :

Define angular offset  $\theta$   
from y-z axis:

Distance to Far-Field  $r_{\min}$ :

$$\theta := 0, \frac{\pi}{2}, \frac{\pi}{2} \quad (\text{radians})$$

$$r_0 := 1.6 \cdot \lambda \quad (\text{m})$$

$$r_1 := 5 \cdot D \quad (\text{m})$$

$$\phi := -\frac{\pi}{2}, \left\{ -\frac{\pi}{2} + \frac{\pi}{1} \right\}, \frac{\pi}{2} \quad (\text{radians})$$

$$r_2 = \frac{2 \cdot D^2}{\lambda} \quad (\text{m})$$

$$r_{\min} := \max(r) \quad (\text{m})$$

$$r_{\min} = 3.04179 \cdot 10^2 \quad (\text{m})$$

Wavenumber k:

$$k := \frac{2 \cdot \pi}{\lambda} \quad (\text{m}^{-1})$$

$$k = 0.20959 \quad (\text{m}^{-1})$$

Ground Relative Complex

Permittivity  $\epsilon_r'$ :

$$\epsilon_p = \epsilon - \frac{j \cdot \sigma}{2 \cdot \pi \cdot f \cdot \epsilon_0} \quad (\text{dimensionless})$$

$$\epsilon_p = 10 - 18j \quad (\text{dimensionless})$$

Vertical Reflection Coefficient  $\Gamma_v$ :

$$w := 0.. \frac{i}{2} \quad (\text{increments})$$

$$\Gamma_v(\theta) := \frac{\epsilon_p \cdot \cos(\theta) - \sqrt{\epsilon_p - \sin(\theta)^2}}{\epsilon_p \cdot \cos(\theta) + \sqrt{\epsilon_p - \sin(\theta)^2}} \quad (\text{dimensionless})$$

$$\Gamma_{v|_w} := \frac{\epsilon_p \cdot \cos\left(\frac{w \cdot \pi}{i}\right) - \sqrt{\epsilon_p - \sin\left(\frac{w \cdot \pi}{i}\right)^2}}{\epsilon_p \cdot \cos\left(\frac{w \cdot \pi}{i}\right) + \sqrt{\epsilon_p - \sin\left(\frac{w \cdot \pi}{i}\right)^2}} \quad (\text{dimensionless})$$

Horizontal Reflection Coefficient  $\Gamma_h$ :

$$\Gamma_h(\theta) := \frac{\cos(\theta) - \sqrt{\epsilon_p - \sin(\theta)^2}}{\cos(\theta) + \sqrt{\epsilon_p - \sin(\theta)^2}} \quad (\text{dimensionless})$$

$$\Gamma_{h|_w} := \frac{\cos\left(\frac{w \cdot \pi}{i}\right) - \sqrt{\epsilon_p - \sin\left(\frac{w \cdot \pi}{i}\right)^2}}{\cos\left(\frac{w \cdot \pi}{i}\right) + \sqrt{\epsilon_p - \sin\left(\frac{w \cdot \pi}{i}\right)^2}} \quad (\text{dimensionless})$$

Electric Field Coefficients A, B:

$$q = 1..M$$

(increments)

$$A(\theta) = \sum_q C_{q-1,0} \cdot e^{j \cdot k \cdot Z_{q-1,0} \cdot (\cos(\theta) - \cos(\theta_0))} \cdot \left\{ 1 - \Gamma_V(\theta) \cdot e^{-j \cdot 2 \cdot k \cdot Z_{q-1,0} \cdot \cos(\theta)} \right\} \quad (\text{dimensionless})$$

$$A1_w = \sum_q C_{q-1,0} \cdot e^{j \cdot k \cdot Z_{q-1,0} \cdot \left\{ \cos\left(\frac{w \cdot \pi}{i}\right) - \cos(\theta_0) \right\}} \cdot \left\{ 1 - \Gamma_V1_w \cdot e^{-j \cdot 2 \cdot k \cdot Z_{q-1,0} \cdot \cos\left(\frac{w \cdot \pi}{i}\right)} \right\} \quad (\text{dimensionless})$$

$$B(\theta) := \sum_q C_{q-1,0} \cdot e^{j \cdot k \cdot Z_{q-1,0} \cdot (\cos(\theta) - \cos(\theta_0))} \cdot \left\{ 1 + \Gamma_h(\theta) \cdot e^{-j \cdot 2 \cdot k \cdot Z_{q-1,0} \cdot \cos(\theta)} \right\} \quad (\text{dimensionless})$$

$$B1_w := \sum_q C_{q-1,0} \cdot e^{j \cdot k \cdot Z_{q-1,0} \cdot \left\{ \cos\left(\frac{w \cdot \pi}{i}\right) - \cos(\theta_0) \right\}} \cdot \left\{ 1 + \Gamma_h1_w \cdot e^{-j \cdot 2 \cdot k \cdot Z_{q-1,0} \cdot \cos\left(\frac{w \cdot \pi}{i}\right)} \right\} \quad (\text{dimensionless})$$

Electric Field Components for Individual Bay  $E_{\theta 1, \phi 1}$ :

$$E_{\theta 1}(\theta, \phi) := -j \cdot 60 \cdot \text{Im} \frac{e^{-j \cdot k \cdot r_{ff}}}{r_{ff}} \frac{\cos(k \cdot l \cdot \sin(\theta) \cdot \sin(\phi)) - \cos(k \cdot l)}{1 - \sin(\theta)^2 \cdot \sin(\phi)^2} \cdot \sin(\phi) \cdot \cos(\theta) \cdot A(\theta) \quad (\text{V/m})$$

$$v := 0..i$$

(increments)

$$E_{\theta 11_{w,v}} := -j \cdot 60 \cdot \text{Im} \frac{e^{-j \cdot k \cdot r_{ff}}}{r_{ff}} \frac{\cos\left\{ k \cdot l \cdot \sin\left(\frac{w \cdot \pi}{i}\right) \cdot \sin\left[-\frac{\pi}{2} + \frac{v \cdot \pi}{i}\right] \right\} - \cos(k \cdot l)}{1 - \sin\left(\frac{w \cdot \pi}{i}\right)^2 \cdot \sin\left[-\frac{\pi}{2} + \frac{v \cdot \pi}{i}\right]^2} \cdot \sin\left[-\frac{\pi}{2} + \frac{v \cdot \pi}{i}\right] \cdot \cos\left(\frac{w \cdot \pi}{i}\right) \cdot A1_w$$



$$E_{\phi 1}(\theta, \phi) := j \cdot 60 \cdot \text{Im} \frac{e^{-j \cdot k \cdot r_{ff}}}{r_{ff}} \frac{\cos(k \cdot l \cdot \sin(\theta) \cdot \sin(\phi)) - \cos(k \cdot l)}{1 - \sin(\theta)^2 \cdot \sin(\phi)^2} \cdot \cos(\phi) \cdot B(\theta) \quad (V/m)$$

$$E_{\phi 11_{w,v}} := j \cdot 60 \cdot \text{Im} \frac{e^{-j \cdot k \cdot r_{ff}} \cos \left\{ k \cdot l \cdot \sin \left( \frac{w \cdot \pi}{i} \right) \cdot \sin \left( -\frac{\pi}{2} + \frac{v \cdot \pi}{i} \right) \right\} - \cos(k \cdot l)}{1 - \sin \left( \frac{w \cdot \pi}{i} \right)^2 \cdot \sin \left( -\frac{\pi}{2} + \frac{v \cdot \pi}{i} \right)^2} \cdot \cos \left\{ -\frac{\pi}{2} + \frac{v \cdot \pi}{i} \right\} \cdot B_{1w} \quad (V/m)$$

Array Factor for N bays  $S_Y$ :

$$q_1 := 1..N \quad (\text{increments})$$

(dimensionless)

$$S_Y(\theta, \phi) := \sum_{q_1} e^{j \cdot k \cdot Y_{0,q_1} - 1 \cdot \sin(\theta) \cdot (\sin(\phi) - \sin(\phi_0))}$$

(dimensionless)

$$S_{Y1_{w,v}} := \sum_{q_1} e^{j \cdot k \cdot Y_{0,q_1} - 1 \cdot \sin \left( \frac{w \cdot \pi}{i} \right) \cdot \left\{ \sin \left( -\frac{\pi}{2} + \frac{v \cdot \pi}{i} \right) - \sin(\phi_0) \right\}}$$

Array Factor for Ideal Reflector  $S_X$ :

(dimensionless)

$$S_X(\theta, \phi) := 1 - e^{-j \cdot 2 \cdot k \cdot X_1 \cdot \sin(\theta) \cdot \cos(\phi)}$$

$$S_{X1_{w,v}} := 1 - e^{-j \cdot 2 \cdot k \cdot X_1 \cdot \sin \left( \frac{w \cdot \pi}{i} \right) \cdot \cos \left( -\frac{\pi}{2} + \frac{v \cdot \pi}{i} \right)}$$

(dimensionless)

Total Electric Field Components  $E_{\theta t, \phi t}$ :

$$E_{\theta t}(\theta, \phi) := E_{\theta 1}(\theta, \phi) \cdot S_x(\theta, \phi) \cdot S_y(\theta, \phi) \quad (\text{V/m})$$

$$E_{\theta t1_{w,v}} := E_{\theta 11_{w,v}} \cdot S_{x1_{w,v}} \cdot S_{y1_{w,v}} \quad (\text{V/m})$$

$$E_{\phi t}(\theta, \phi) := E_{\phi 1}(\theta, \phi) \cdot S_x(\theta, \phi) \cdot S_y(\theta, \phi) \quad (\text{V/m})$$

$$E_{\phi t1_{w,v}} := E_{\phi 11_{w,v}} \cdot S_{x1_{w,v}} \cdot S_{y1_{w,v}} \quad (\text{V/m})$$

Radiation Intensity  $U(\theta)$ :

$$U(\theta, \phi) := \frac{r^2}{2 \cdot \eta_0} \cdot \left[ (|E_{\theta t}(\theta, \phi)|)^2 + (|E_{\phi t}(\theta, \phi)|)^2 \right] \quad (\text{W/solid angle})$$

$$U1_{w,v} := \frac{r^2}{2 \cdot \eta_0} \cdot \left[ (|E_{\theta t1_{w,v}}|)^2 + (|E_{\phi t1_{w,v}}|)^2 \right] \quad (\text{W/solid angle})$$

$$U_{\max} := \max(U1) \quad (\text{W/solid angle})$$

$$U_{\max} = 8.8082 \cdot 10^3 \quad (\text{W/solid angle})$$

Radiated Power  $P_{\text{rad}}$ :

$$P_{\text{rad}} := \int_{-\frac{\pi}{2}}^{\frac{\pi}{2}} \int_0^{\frac{\pi}{2}} U(\theta, \phi) \cdot \sin(\theta) \, d\theta \, d\phi \quad (\text{W})$$

$$P_{\text{rad}} = 9.79181 \cdot 10^2 \quad (\text{W})$$

Directivity  $D_0$ :

$$D_0 = \frac{4 \cdot \pi \cdot U_{\max}}{P_{\text{rad}}} \quad (\text{dimensionless})$$

$$D_0 = 1.13041 \cdot 10^2 \quad (\text{dimensionless})$$

Magnitude of Antenna Feed Current

$I_0$ :

$$I_0 := M \cdot N \cdot I_m \quad (\text{amps})$$

$$I_0 = 8 \quad (\text{amps})$$

Radiation Resistance ( $R_r$ ):

$$R_r := \frac{2 \cdot P_{\text{rad}}}{(|I_0|)^2} \quad (\Omega)$$

$$R_r = 30.5994 \quad (\Omega)$$

Gain  $G$ :

$$G_{\text{db}} := 10 \cdot \log(D_0) - 2 \quad (\text{dB})$$

$$G_{\text{db}} = 18.53234 \quad (\text{dB})$$

$$G = 10^{\frac{G_{\text{db}}}{10}} \quad (\text{dimensionless})$$

$$G = 71.32377 \quad (\text{dimensionless})$$

Polarization Loss Factor PLF:

$$\theta_p := \operatorname{atan} \left( \frac{\sqrt{x^2 + y^2}}{z} \right) \quad (\text{radians})$$

$$\phi_p := \operatorname{atan} \left( \frac{y}{x} \right) \quad (\text{radians})$$

$$\theta_p = 1.5209 \quad (\text{radians})$$

$$\phi_p = 0.04996 \quad (\text{radians})$$

$$E_x := E\theta(\theta_p, \phi_p) \cdot \cos(\theta_p) \cdot \cos(\phi_p) - E\phi(\theta_p, \phi_p) \cdot \sin(\phi_p) \quad (\text{V/m})$$

$$E_y := E\theta(\theta_p, \phi_p) \cdot \cos(\theta_p) \cdot \sin(\phi_p) - E\phi(\theta_p, \phi_p) \cdot \cos(\phi_p) \quad (\text{V/m})$$

$$E_z := E\theta(\theta_p, \phi_p) \sin(\theta_p) \quad (\text{V/m})$$

$$\sigma_a := \frac{1}{\sqrt{(|E_x|)^2 + (|E_y|)^2 + (|E_z|)^2}} \begin{Bmatrix} E_x \\ E_y \\ E_z \end{Bmatrix} \quad (\text{dimensionless})$$

$$\sigma_a = \begin{bmatrix} -0.03302 + 0.03754j \\ -0.66366 + 0.74634j \\ -3.33112 \cdot 10^{-3} - 4.40961 \cdot 10^{-3}j \end{bmatrix} \quad (\text{dimensionless})$$

$$\text{PLF} := \left( \left| \sigma_w \cdot \sigma_a \right| \right)^2 \quad (\text{dimensionless})$$

$$\text{PLF} = 0.54991 \quad (\text{dimensionless})$$

Maximum Effective Aperture ( $A_{em}$ ):

$$A_{em} := \frac{\lambda^2 \cdot D_0 \cdot \text{PLF}}{4 \cdot \pi} \quad (\text{m}^2)$$

$$A_{em} = 4.44582 \cdot 10^3 \quad (\text{m}^2)$$

Effective Isotropic Radiated Power (EIRP):

EIRP = Prad · Do (W)

EIRP = 1.10687 10<sup>5</sup> (W)

Maximum Effective Height (h<sub>em</sub>):

hem :=  $\sqrt{\frac{Rr \cdot Aem}{\eta_0}} \cdot 2$  (m)

hem = 37.99241 (m)

Bandwidth BW:

Half-Wave Assembly

Symmetric Feed Assembly

f<sub>l2</sub> =  $\frac{c}{4 \cdot l}$  (Hz)

f<sub>high1</sub> := 1.5 · f<sub>l2</sub> (Hz)

f<sub>l2</sub> = 6.81341 10<sup>6</sup> (Hz)

f<sub>low1</sub> = .98 · f<sub>l2</sub> (Hz)

f<sub>high</sub> := 1.02 · f<sub>l2</sub> (Hz)

BW<sub>1</sub> = f<sub>high1</sub> - f<sub>low1</sub> (Hz)

f<sub>low</sub> := .98 · f<sub>l2</sub> (Hz)

BW<sub>1</sub> = 3.54297 10<sup>6</sup> (Hz)

BW = f<sub>high</sub> - f<sub>low</sub> (Hz)

BW = 2.72536 10<sup>5</sup> (Hz)

BEDSPRING ANTENNA AZIMUTHAL FAR FIELD PATTERN

For the purpose of this far-field radiation pattern, the bedspring antenna lies on the  $E_y = 0$  grid line. Three field patterns are developed: the  $(\theta)$  component of electric field, the  $(\phi)$  component of electric field, the total electric field. The user must select the desired coaltitude  $(\theta_g)$  for which the patterns will be graphed.

Theta Component of Azimuthal Electric Field

$$\theta_g := \frac{\pi}{2}$$

$$E_{\theta x}(\phi) := |E_{\theta}(\theta_g, \phi)| \cdot \cos\left\{\phi + \frac{\pi}{2}\right\} \qquad E_{\theta y}(\phi) := |E_{\theta}(\theta_g, \phi)| \cdot \sin\left\{\phi + \frac{\pi}{2}\right\}$$

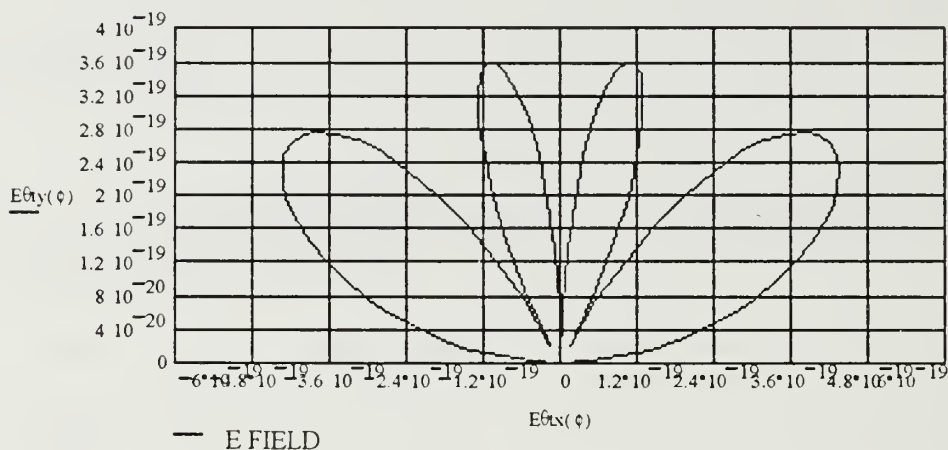

Phi Component of Azimuthal Electric Field

$$E_{\phi x}(\phi) := |E_{\phi}(\theta_g, \phi)| \cdot \cos\left\{\phi + \frac{\pi}{2}\right\} \qquad E_{\phi y}(\phi) := |E_{\phi}(\theta_g, \phi)| \cdot \sin\left\{\phi + \frac{\pi}{2}\right\}$$

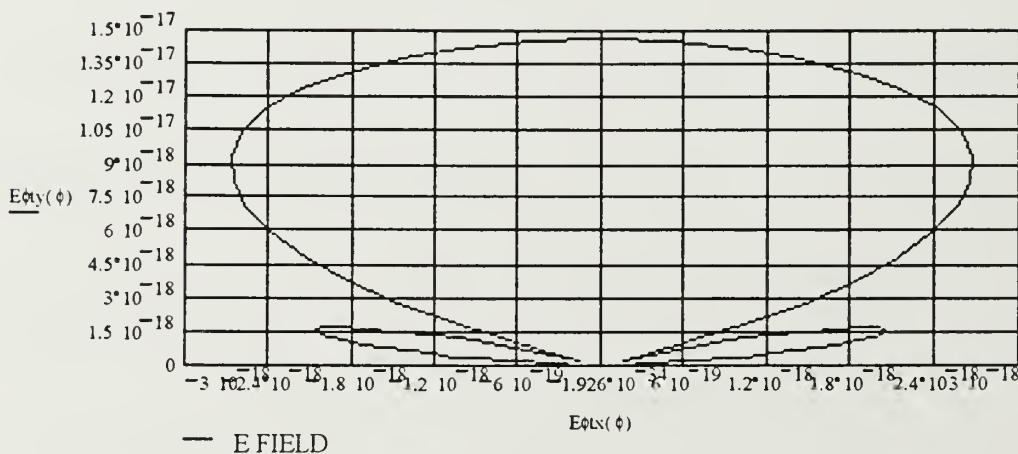

$$Et(\phi) := \sqrt{(|E\theta t(\theta g, \phi)|)^2 + (|E\phi t(\theta g, \phi)|)^2}$$

$$Et_x(\phi) := |Et(\phi)| \cos\left\{\phi + \frac{\pi}{2}\right\}$$

$$Et_y(\phi) := |Et(\phi)| \sin\left\{\phi + \frac{\pi}{2}\right\}$$

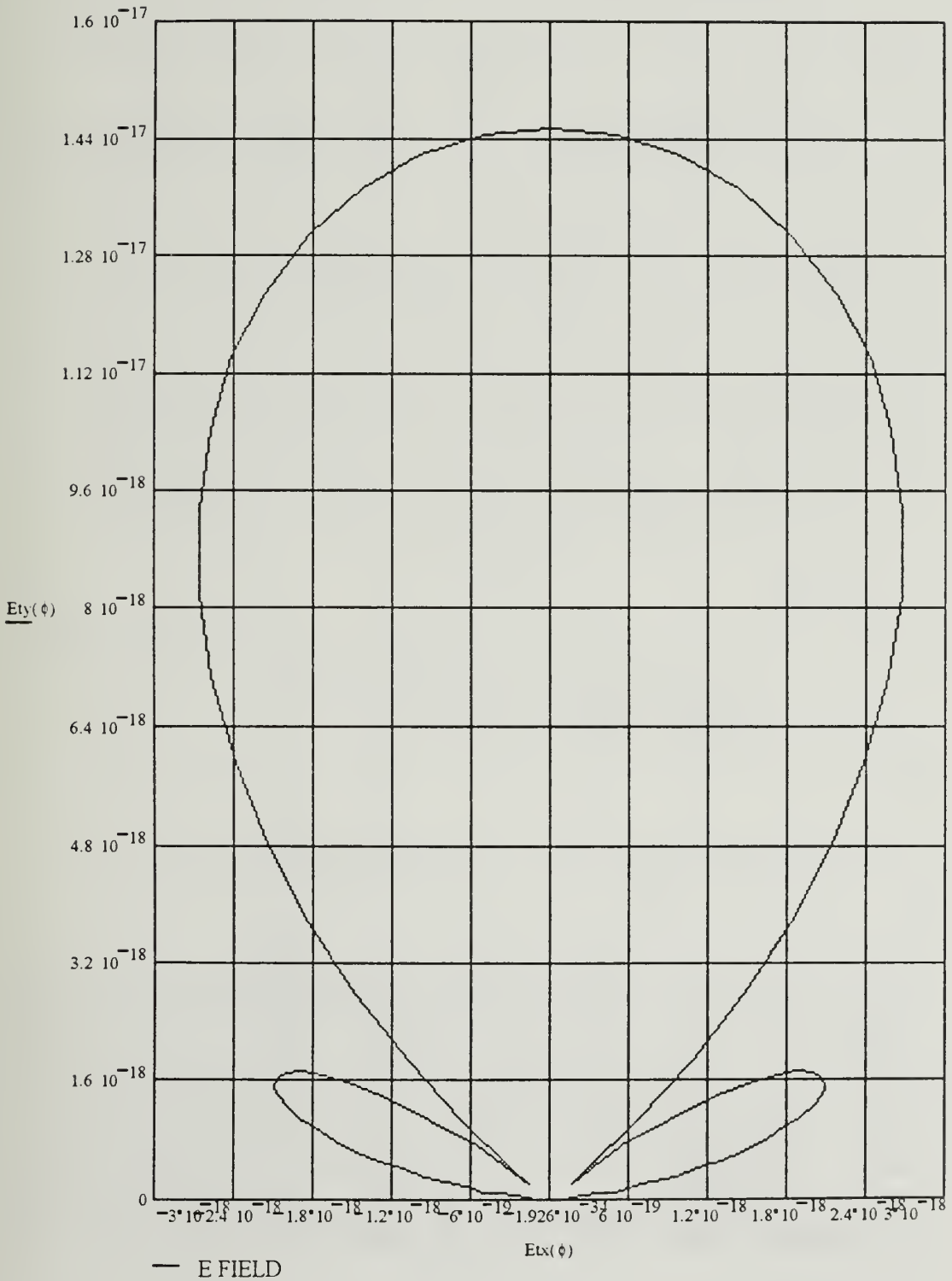



BEDSPRING ANTENNA ELEVATION FAR FIELD PATTERN

For the purpose of this far-field radiation pattern, the bedspring antenna lies on the  $E_x = 0$  grid line. Three field patterns are developed: the  $(\theta)$  component of electric field, the  $(\phi)$  component of electric field, the total electric field. The user must select the desired aximuth angle  $(\phi_g)$  for which the elevation patterns will be graphed.

Theta Component of Elevation Pattern of  
Electric Field

$$\phi_g = 0$$

$$E_{\theta x}(\theta) := \left| E_{\theta t} \left( \frac{\pi}{2} - \theta, \phi_g \right) \right| \cdot \cos(\theta) \qquad E_{\theta y}(\theta) := \left| E_{\theta t} \left( \frac{\pi}{2} - \theta, \phi_g \right) \right| \cdot \sin(\theta)$$

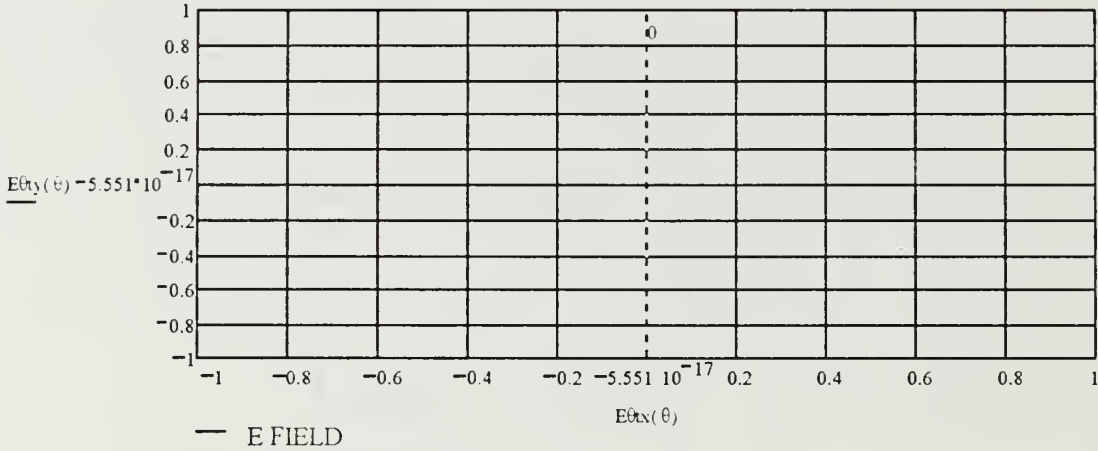

Phi Component of Elevation Pattern of  
Electric Field

$$E_{\phi x}(\theta) := \left| E_{\phi t} \left( \frac{\pi}{2} - \theta, \phi_g \right) \right| \cdot \cos(\theta) \qquad E_{\phi y}(\theta) := \left| E_{\phi t} \left( \frac{\pi}{2} - \theta, \phi_g \right) \right| \cdot \sin(\theta)$$

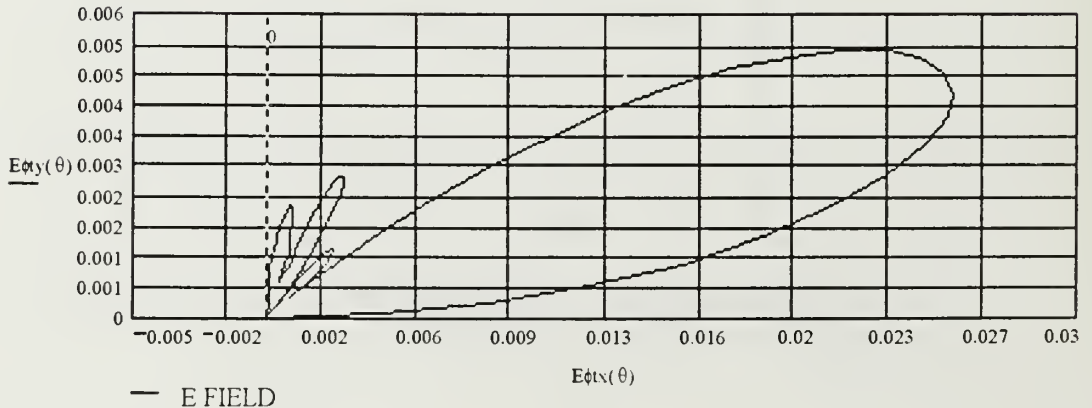

Elevation Plot of Total Electric Field

$$Et(\theta) := \sqrt{(|E\theta(\theta, \phi_g)|)^2 + (|E\phi(\theta, \phi_g)|)^2}$$

$$Et_x(\theta) := \left| Et\left(\frac{\pi}{2} - \theta\right) \right| \cdot \cos(\theta)$$

$$Et_y(\theta) := \left| Et\left(\frac{\pi}{2} - \theta\right) \right| \cdot \sin(\theta)$$

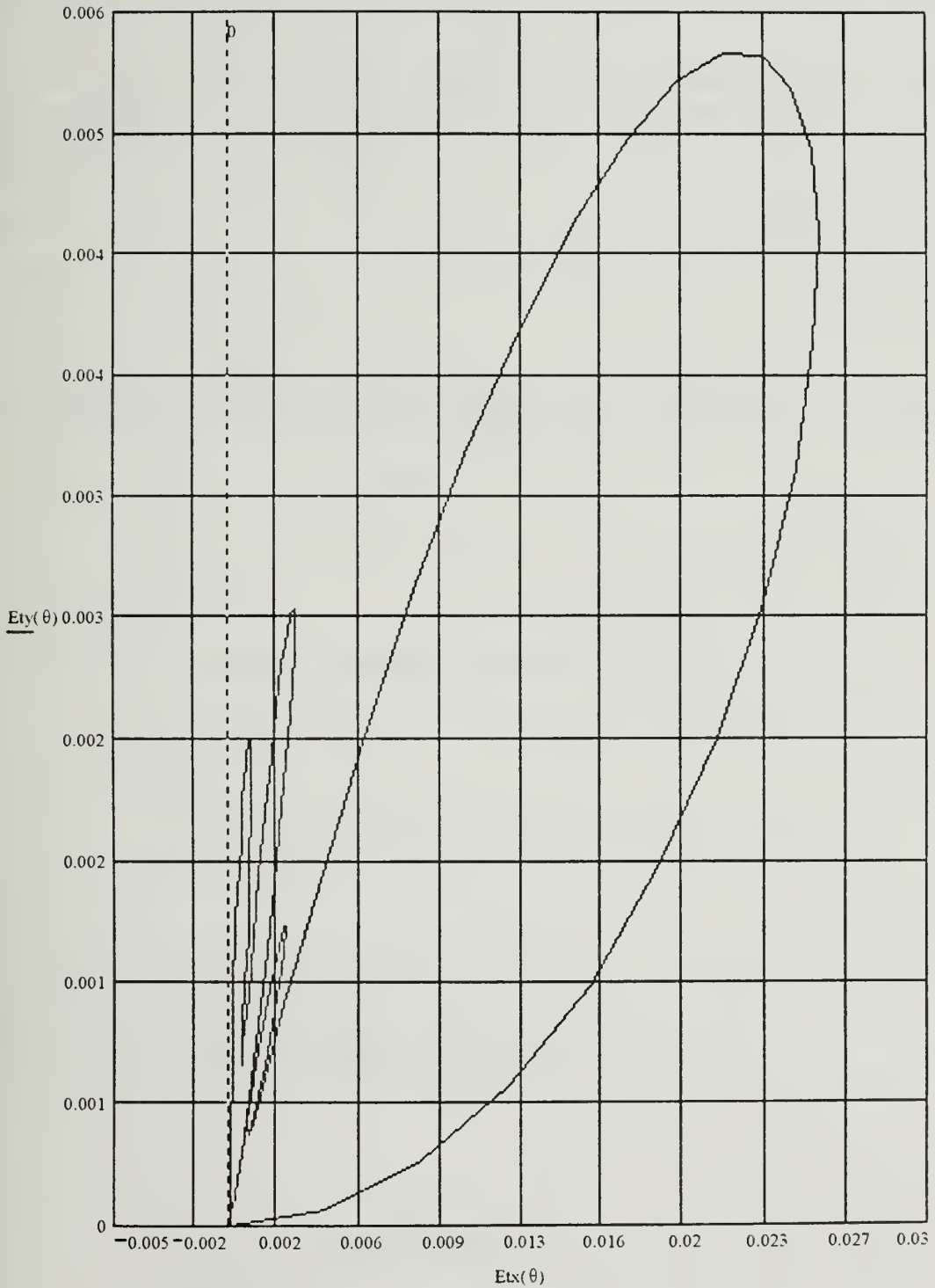

— E FIELD

Spiral antennas are a family of two or three dimensional devices that possess frequency independent parameters over a wide bandwidth. Spiral antennas are commonly used for direction finding, satellite tracking and missile guidance.

The planar spiral may be of the Archimedean, log-spiral, or equiangular type. All three radiate two main, circularly polarized lobes perpendicular to the plane of the antenna. Additional gain for planar spirals may be achieved by placing a metal cavity on the side of the antenna with the unwanted lobe. The cavity may be empty or be filled with electromagnetic energy absorbing material. These applications principally examine the equiangular planar spiral and do not account for cavity backed effects.

The three dimensional, or conical, spiral exhibits many of the same features as the planar spiral except that it radiates a single main beam in the direction of its tip, thereby eliminating the need for cavities. The conical log-spiral is the only three dimensional antenna analyzed by this application.

(Note: Mathcad equations cannot use symbolic subscripts. Therefore, symbols like  $\lambda$  will immediately follow the parameter in equations in lieu of subscripts. )

The spiral antenna Mathcad applications will compute the following parameters for equiangular planar spirals and conical log-spirals:

$k$  = Wavenumber  
 $\lambda$  = Wavelength  
 $D_o$  = Directivity  
 $E_\theta$  = Electric Field ( $\theta$ ) Component  
 $E_\phi$  = Electric Field ( $\phi$ ) Component  
A,B,C = Conical Log-Spiral Electric Field Coefficients  
U = Radiation Intensity  
 $U_{max}$  = Maximum Radiation Intensity  
 $P_{rad}$  = Radiated Power  
G = Gain  
EIRP = Effective Isotropic Radiated Power  
 $A_{em}$  = Maximum Effective Aperture  
BW = Bandwidth  
 $r_{min}$  = Minimum Distance to Far-Field  
 $R_r$  = Radiation Resistance  
 $h_{em}$  = Maximum Effective Height  
 $E_{x,y,z}$  = Conical Log-Spiral Electric Field Spatial Components  
 $\sigma_a$  = Conical Log-Spiral Unit Polarization Vector  
 $f_{high}$  = Upper Operating Frequency  
 $f_{low}$  = Lower Operating Frequency  
 $r_n$  = Any point on the  $n^{th}$  edge of a spiral  
 $\epsilon_{ex}$  = Equiangular Planar Spiral Expansion Ratio  
 $Z_i$  = Planar Spiral Input Impedance  
 $\Gamma$  = Voltage Reflection Coefficient

$\epsilon_{RV}$  = Reflection Efficiency  
 PLF = Polarization Loss Factor  
 Q = Conical Log-Spiral Antenna Slowness Factor  
 $I(\xi)$  = Conical Log-Spiral Current Distribution  
 $\phi(\xi)$  = Conical Log-Spiral Azimuth  
 $\alpha_n$  = Conical Log-Spiral Phase Difference of  $n^{\text{th}}$  arm  
 $\lambda_{\text{high}}$  = Upper Operating Wavelength  
 $\lambda_{\text{low}}$  = Lower Operating Wavelength  
 $\beta$  = Planar Spiral Angle  
 A = Planar Spiral Electric Field Amplitude  
 b = Conical Log-Spiral Constant  
 L = Conical Log-Spiral Total Arm Length  
 $\phi_L$  = Conical Log-Spiral Azimuth at End of Arm  
 $\theta_p$  = Desired Conical Log-Spiral Polarization Offset Angle from z Axis  
 $\phi_p$  = Desired Conical Log-Spiral Polarization Azimuth Angle  
 L = Conical Log-Spiral Total Arm Length

The following data must be input based on known or estimated data:

M = Mode  
 N = Number of Spiral Arms  
 f = Frequency of Interest  
 i = Number of Increments for Far Field Radiation Patterns  
 $r_{\text{ff}}$  = Distance of Far-Field Calculations  
 $I_0$  = Input Current at Antenna Terminals  
 $\theta_g$  = Deflection Angle from +z Axis for Azimuth Plot  
 $\phi_g$  = Azimuth Angle for Elevation Plot  
 $(x, y, z)$  = Coordinates for Conical Log-Spiral Unit Polarization Vector  
 $r_0$  = Spiral Feed Point  
 a = Flare Rate  
 $\delta_{n+1}$  = Angular Arm Width of  $n^{\text{th}}$  Spiral Arm  
 $\phi_{\text{ex}}$  = Azimuth to Compute Expansion Ratio  
 $\beta$  = Conical Log-Spiral Angle  
 R = Overall Radius  
 $E_0$  = Source Strength Constant for Planar Spirals  
 $Z_i$  = Conical Log-Spiral Input Impedance  
 $\sigma_w$  = Wave Unit Polarization Vector  
 $\theta_0$  = Cone Angle  
 $\Delta\theta$  = Conical Log-Spiral Half-Power Beamwidth  
 $Z_0$  = Characteristic Impedance of Feed Assembly  
 t = Number of Increments Along Conical Log-Spiral Arm  
 $\sigma_a$  = Equiangular Planar Spiral Unit Polarization Vector

THE PLANAR SPIRAL ANTENNAS

Enter input data here:

$N := 2$  (arms)  $f := 3 \cdot 10^6$  (Hz)

$M := 1$  (mode)  $I_0 := 1$  (amps)

(Note:  $M_{\max}$  is  $N-1$ )

$rff := 1 \cdot 10^3$  (meters)

$i := 30$  (increments)

$r_0 := 1$  (m)

$a := .221$  (dimensionless)

$E_0 = 10^3$  (V/m)

$R := 1$  (m)

$\delta = \begin{bmatrix} 0 \\ \frac{\pi}{2} \\ \pi \\ \frac{3 \cdot \pi}{2} \end{bmatrix}$  (radians)

$\sigma_w := \begin{bmatrix} 1 \\ \sqrt{2} \\ j \\ \sqrt{2} \\ 0 \end{bmatrix}$  (dimensionless)

$Z_0 = 100$  ( $\Omega$ )

Calculate planar spiral antenna geometric parameters and define constants:

$c := 2.9979 \cdot 10^8$  (meters/sec)

$\eta_0 := 120 \cdot \pi$  ( $\Omega$ )

$\lambda = \frac{c}{f}$  (meters/cycle)

$\epsilon_0 := \frac{1}{36 \cdot \pi} \cdot 10^{-9}$  (Farads/m)

$\lambda = 99.93$  (meters/cycle)

$\mu_0 := 4 \cdot \pi \cdot 10^{-7}$  (H/m)

$\sigma_a = \begin{bmatrix} 1 \\ \sqrt{2} \\ j \\ \sqrt{2} \\ 0 \end{bmatrix}$  (dimensionless)

Calculate planar spiral antenna parameters :

Define angular offset  $\theta$   
from y-z axis:

Distance to Far-Field  $r_{\min}$ :

$$\theta := -\frac{\pi}{2}, \frac{\pi}{2}, \frac{\pi}{2}, \frac{\pi}{2} \quad (\text{radians})$$

$$r_0 := 1.6 \cdot \lambda \quad (\text{m})$$

$$r_1 := 10 \cdot R \quad (\text{m})$$

$$\phi := 0, \frac{2 \cdot \pi}{i} \dots 2 \cdot \pi \quad (\text{radians})$$

$$r_2 := \frac{8 \cdot R^2}{\lambda} \quad (\text{m})$$

$$r_{\min} = \max(r_i) \quad (\text{m})$$

$$r_{\min} = 1.59888 \cdot 10^2 \quad (\text{m})$$

Wavenumber  $k$ :

$$k = \frac{2 \cdot \pi}{\lambda} \quad (\text{m}^{-1})$$

$$k = 0.06288 \quad (\text{m}^{-1})$$

Radial Distance to  $n^{\text{th}}$  Spiral Edge  $r$ :

$$r(n, \phi_r) := r_0 \cdot e^{a \cdot (\phi_r - \delta_{n-1})} \quad (\text{m})$$

$$r(1, 2 \cdot \pi) = 0.40092 \quad (\text{m})$$

Expansion Ratio  $\epsilon_{\text{ex}}$ :

$$\epsilon_{\text{ex}}(n, \phi_r) := \frac{r(n, \phi_r + 2 \cdot \pi)}{r(n, \phi_r)} \quad (\text{dimensionless})$$

$$\epsilon_{\text{ex}}(1, 2 \cdot \pi) = 4.00917 \quad (\text{dimensionless})$$

Bandwidth BW:

<u>Equiangular Spiral</u>		<u>Log-Periodic Spiral</u>	
$\lambda_{high} = 4 r_0$	(m)	$\lambda_{high1} = 20 r_0$	(m)
$f_{high} = \frac{c}{\lambda_{high}}$	(Hz)	$f_{high1} = \frac{c}{\lambda_{high1}}$	(Hz)
$f_{high} = 7.49475 \cdot 10^8$	(Hz)	$f_{high} = 7.49475 \cdot 10^8$	(Hz)
$\lambda_{low} = 4 \cdot R$	(m)		
$f_{low} = \frac{c}{\lambda_{low}}$	(Hz)		
$f_{low} = 7.49475 \cdot 10^7$	(Hz)		
$BW = f_{high} - f_{low}$	(Hz)	$BW1 = f_{high1} - f_{low}$	(Hz)
$BW = 6.74528 \cdot 10^8$	(Hz)	$BW1 = 7.49475 \cdot 10^7$	(Hz)

Electric Field  $E(\theta, \phi)$  and Electric Field Amplitude  $A(\theta)$ :

$w = 0..i$  (increments)

$$E_{\phi}(\phi, \theta) = \frac{E_0 k^3 \cdot \cos(\theta) \cdot (1 + j \cdot a \cdot \cos(\theta))^{-1 - \frac{j \cdot M}{2} \cdot \tan\left(\frac{\theta}{2}\right)^M \cdot j \cdot \left[M \cdot \left(\theta + \frac{\pi}{2}\right) - k \cdot r_{ff}\right]}{\sin(\theta)^2 \cdot r_{ff}} \cdot e^{-j \cdot M \cdot \phi} \quad (\text{V/m})$$

$$E_{\phi}\left(\frac{\pi}{6}, \frac{\pi}{6}\right) = 5.97188 \cdot 10^{-5} + 2.4182 \cdot 10^{-4} j \quad (\text{V/m})$$

Electric Field Amplitude A:

$$A(\theta) = \frac{\cos(\theta) \cdot \tan\left(\frac{\theta}{2}\right)^M \cdot e^{\left(\frac{M}{a}\right) \cdot a \cdot \tan(a \cdot \cos(\theta))}}{\sin(\theta) \cdot \sqrt{1 + a^2 \cdot \cos(\theta)^2}} \quad (\text{V/m})$$

$$A1_w = \frac{\cos\left(-\frac{\pi}{2} + \pi \cdot \frac{w}{i}\right) \cdot \tan\left(\frac{-\frac{\pi}{2} + \pi \cdot \frac{w}{i}}{2}\right)^M \cdot e^{\left(\frac{M}{a}\right) \cdot a \cdot \cos\left(-\frac{\pi}{2} + \pi \cdot \frac{w}{i}\right)}}{\sin\left(-\frac{\pi}{2} + \pi \cdot \frac{w}{i}\right) \cdot \sqrt{1 + a^2 \cdot \cos\left(-\frac{\pi}{2} + \pi \cdot \frac{w}{i}\right)^2}} \quad (\text{V/m})$$

Radiation Intensity U( $\theta$ ):

$$U(\theta) = \frac{1}{2 \cdot \eta_0} \cdot (A(\theta))^2 \quad (\text{W / solid angle})$$

$$U1_w = \frac{1}{2 \cdot \eta_0} \cdot [(A1_w)^2] \quad (\text{W / solid angle})$$

$$U_{\max} = \max(U1) \quad (\text{W / solid angle})$$

$$U_{\max} = 2.2285 \cdot 10^{-3} \quad (\text{W / solid angle})$$

Radiated Power Prad:

$$\text{Prad} = 4 \cdot \pi \cdot \int_0^{\frac{\pi}{2}} U(\theta) \cdot \sin(\theta) \, d\theta \quad (\text{W})$$

$$\text{Prad} = 7.94528 \cdot 10^{-3} \quad (\text{W})$$



Directivity  $D_o$ :

$$D_o = \frac{4 \cdot \pi \cdot U_{\max}}{P_{\text{rad}}} \quad (\text{dimensionless})$$

$$D_o = 3.52462 \quad (\text{dimensionless})$$

Radiation Resistance  $R_r$ :

$$R_r = \frac{2 \cdot P_{\text{rad}}}{(|I_o|)^2} \quad (\Omega)$$

$$R_r = 0.01589 \quad (\Omega)$$

Input Impedance  $Z_i$ :

$$Z_i = \frac{N \cdot 30 \cdot \pi}{\sin\left(\pi \cdot \frac{M}{N}\right)} \quad (\Omega)$$

$$Z_i = 1.88496 \cdot 10^2 \quad (\Omega)$$

Voltage Reflection Coefficient  $\Gamma$ :

$$\Gamma = \frac{Z_i - Z_o}{Z_i + Z_o} \quad (\text{dimensionless})$$

$$\Gamma = 0.30675 \quad (\text{dimensionless})$$

Reflection Efficiency  $\epsilon_{rv}$ :

$$\epsilon_{rv} = 1 - (|\Gamma|)^2 \quad (\text{dimensionless})$$

$$\epsilon_{rv} = 0.90591 \quad (\text{dimensionless})$$

$$G := \sigma v \cdot D_o \quad (\text{dimensionless})$$

$$G = 3.19298 \quad (\text{dimensionless})$$

$$G_{dB} := 10 \cdot \log(G) \quad (\text{dB})$$

$$G_{dB} = 5.04196 \quad (\text{dB})$$

Effective Isotropic Radiated Power (EIRP):

$$\text{EIRP} := \text{Prad} \cdot D_o \quad (\text{W})$$

$$\text{EIRP} = 0.028 \quad (\text{W})$$

Polarization Loss Factor (PLF):

$$\text{PLF} := \left( \left| \frac{\sigma_w \cdot \sigma_a}{\sigma_w \cdot \sigma_a} \right| \right)^2 \quad (\text{dimensionless})$$

$$\text{PLF} = 1 \quad (\text{dimensionless})$$

Maximum Effective Aperture ( $A_{em}$ ):

$$A_{em} := \frac{\lambda^2 \cdot D_o \cdot \sigma v \cdot \text{PLF}}{4 \cdot \pi} \quad (\text{m}^2)$$

$$A_{em} = 2.53733 \cdot 10^3 \quad (\text{m}^2)$$

Maximum Effective Height ( $h_{em}$ ):

$$h_{em} = \sqrt{\frac{Rr \cdot A_{em}}{\eta_0}} \cdot 2 \quad (\text{m})$$

$$h_{em} = 0.65407 \quad (\text{m})$$

THE EQUIANGULAR PLANAR SPIRAL ANTENNA FAR-FIELD ELEVATION PATTERN

For the purpose of this far-field radiation pattern, the spiral antenna lies parallel to the  $E_y = 0$  grid line and is centered at the origin. The magnitude of the electric field pattern is rotationally symmetric with respect to the  $E_x=0$  grid line. The equiangular planar spiral antenna possesses a mirror image radiation pattern in the  $-y$  half plane.

$$E_{\phi x}(\theta) = |A(\theta)| \cdot \cos\left(\theta + \frac{\pi}{2}\right)$$

$$E_{\phi y}(\theta) = |A(\theta)| \cdot \sin\left(\theta + \frac{\pi}{2}\right)$$

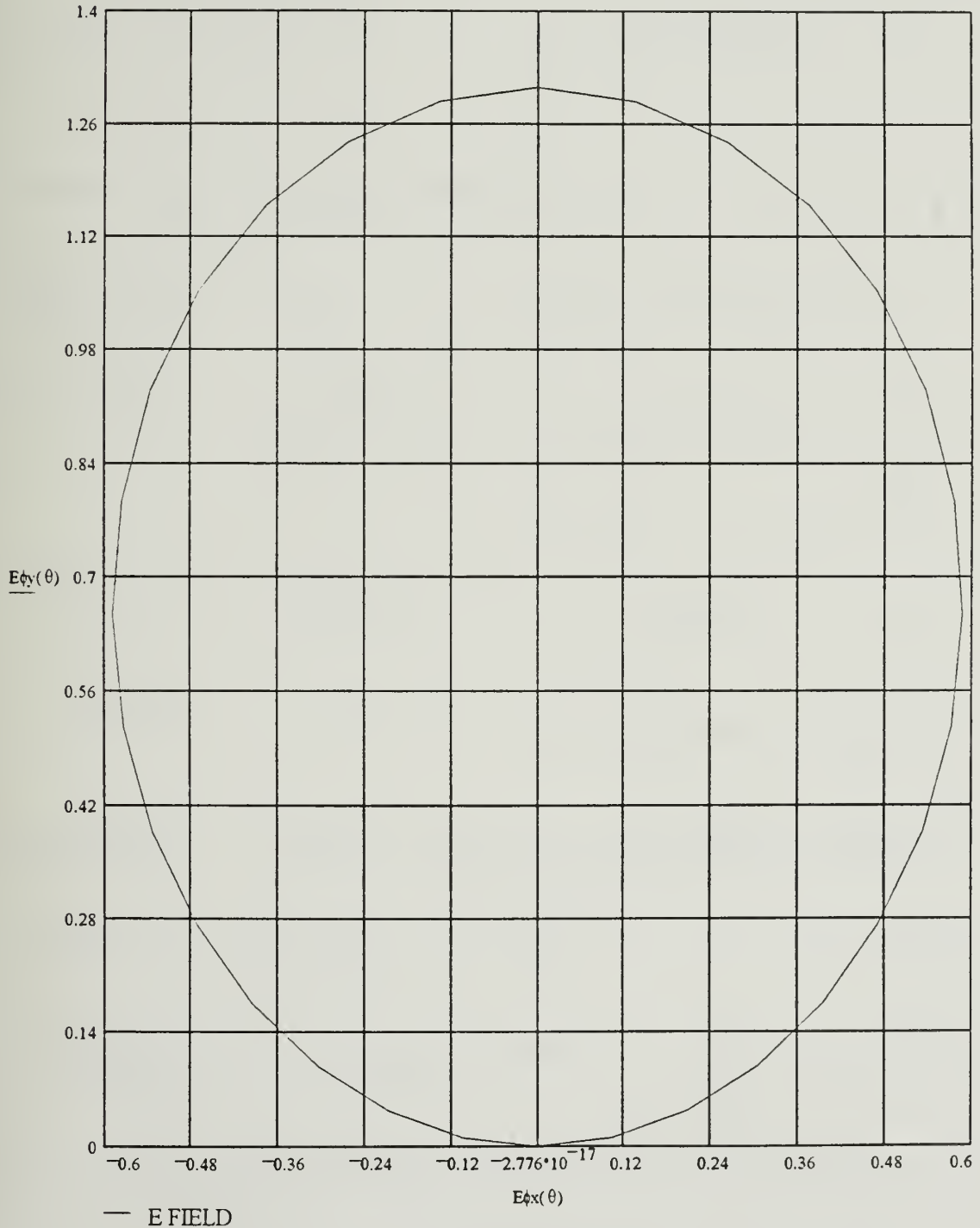

THE CONICAL SPIRAL ANTENNAS

Enter input data here:

N = 2 (arms)

f := 280 · 10<sup>6</sup> (Hz)

M = 1 (mode)

I<sub>0</sub> := 1 (amps)

(Note: M<sub>max</sub> is N-1)

i := 9 (increments)

rff = 1 · 10<sup>4</sup> (meters)

ro := .03 (m)

R := .15 (m)

Zi := 160 (Ω)

$$\delta = \begin{bmatrix} 0 \\ \frac{\pi}{2} \\ \pi \\ 3 \cdot \frac{\pi}{2} \end{bmatrix} \quad (\text{radians})$$

$$\sigma w = \begin{bmatrix} \frac{1}{\sqrt{2}} \\ j \\ \frac{j}{\sqrt{2}} \\ 0 \end{bmatrix} \quad (\text{dimensionless})$$

β := 73 (degrees)

Z<sub>0</sub> = 100 (Ω)

β = β ·  $\frac{\pi}{180}$  (radians)

θ<sub>0</sub> := 10 (degrees)

β = 1.27409 (radians)

θ<sub>0</sub> = θ<sub>0</sub> ·  $\frac{\pi}{180}$  (radians)

x := 0 (m)

θ<sub>0</sub> = 0.17453 (radians)

y := 0 (m)

z := 10<sup>4</sup> (m)

HPBW := 80 (degrees)

Calculate conical log-spiral antenna geometric parameters and define constants:

$$c := 2.9979 \cdot 10^8 \quad (\text{meters/sec}) \qquad \eta_0 := 120 \cdot \pi \quad (\Omega)$$

$$\lambda := \frac{c}{f} \quad (\text{meters/cycle}) \qquad \epsilon_0 = \frac{1}{36 \cdot \pi} \cdot 10^{-9} \quad (\text{Farads/m})$$

$$\lambda = 1.07068 \quad (\text{meters/cycle}) \qquad \mu_0 := 4 \cdot \pi \cdot 10^{-7} \quad (\text{H/m})$$

Calculate conical log-spiral antenna parameters :

Define angular offset  $\theta$   
from y-z axis:

$$\theta = -\frac{\pi}{2}, \frac{\pi}{2}, -\frac{\pi}{2}, \frac{\pi}{2} \quad (\text{radians})$$

$$\phi = 0, \frac{2 \cdot \pi}{i} .. 2 \cdot \pi \quad (\text{radians})$$

Distance to Far-Field rmin:

$$\pi_0 := 1.6 \cdot \lambda \quad (\text{m})$$

$$\pi_1 := 10 \cdot R \quad (\text{m})$$

$$\pi_2 := \frac{8 \cdot R^2}{\lambda} \quad (\text{m})$$

$$r_{min} = \max(\pi) \quad (\text{m})$$

$$r_{min} = 1.71309 \quad (\text{m})$$

Wavenumber k:

$$k := \frac{2 \cdot \pi}{\lambda} \quad (\text{m}^{-1})$$

$$k = 5.86841 \quad (\text{m}^{-1})$$

Radial Distance to  $n^{\text{th}}$  Spiral Edge r:

$$b := \cot(\beta) \quad (\text{dimensionless})$$

$$b = 0.30573 \quad (\text{dimensionless})$$

$$r(n, \phi r) := r_0 \cdot e^{b \cdot \sin(\theta_0) \cdot (\phi r - \delta_{n+1})} \quad (\text{m})$$

$$r(1, 4 \cdot \pi) = 0.04948 \quad (\text{m})$$

Bandwidth BW:

Conical Log-Spiral

$$\lambda_{\text{high}} = 4 \cdot r_0 \quad (\text{m})$$

$$f_{\text{high}} = \frac{c}{\lambda_{\text{high}}} \quad (\text{Hz})$$

$$f_{\text{high}} = 2.49825 \cdot 10^9 \quad (\text{Hz})$$

$$\lambda_{\text{low}} = \frac{8}{3} \cdot R \quad (\text{m})$$

$$f_{\text{low}} = \frac{c}{\lambda_{\text{low}}} \quad (\text{Hz})$$

$$f_{\text{low}} = 7.49475 \cdot 10^8 \quad (\text{Hz})$$

$$\text{BW} = f_{\text{high}} - f_{\text{low}} \quad (\text{Hz})$$

Antenna Slowness Factor Q:

$$Q = \sqrt{1 + \frac{1}{b^2}} \quad (\text{dimensionless})$$

$$Q = 3.4203 \quad (\text{dimensionless})$$

Azimuth at End of the First Spiral Arm  $\phi_L$ :

$$\phi_L = \frac{1}{b \cdot \sin(\theta_0)} \cdot \ln \left( \frac{R}{r_0 \cdot \sin(\theta_0)} \right) \quad (\text{radians})$$

$$\phi_L = 63.29231 \quad (\text{radians})$$

Spiral Arm Length L:

$$L = \frac{r_0}{b} \cdot \left( e^{\phi L \cdot b \cdot \sin(\theta_0)} - 1 \right) \quad (\text{m})$$

$$L = 2.72729 \quad (\text{m})$$

Spiral Arm Current I(ξ):

$$t = 25 \quad (\text{increments})$$

$$\xi := 0, \frac{L}{t} \dots L \quad (\text{m})$$

$$I(\xi) = I_0 \cdot e^{-\frac{\xi^2}{L}} \quad (\text{amps})$$

Electric Field Coefficients α, A(ξ), B(ξ), C(ξ), D(ξ), φ(ξ):

$$\alpha = \frac{2 \cdot \pi}{N} \quad (\text{dimensionless})$$

$$\alpha = 3.14159 \quad (\text{dimensionless})$$

$$l = 0 \dots N - 1 \quad (\text{increments})$$

$$v = 0 \dots \frac{i}{2} \quad (\text{increments})$$

$$w = 0 \dots i \quad (\text{increments})$$

$$\phi l(\xi) := \frac{1}{b \cdot \sin(\theta_0)} \cdot \ln \left( \frac{\xi \cdot b}{r_0} + 1 \right) \quad (\text{radians})$$

$$C\theta(\xi, \phi, l) := \left( 1 + \frac{j}{b \cdot \sin(\theta_0)} \right) \cdot e^{j \cdot (\phi l(\xi) - \phi + l \cdot \alpha)} + \left( 1 - \frac{j}{b \cdot \sin(\theta_0)} \right) \cdot e^{-j \cdot (\phi l(\xi) - \phi + l \cdot \alpha)} \quad (\text{dimensionless})$$



$$C1\theta(\xi, w, l) := \left(1 + \frac{j}{b \cdot \sin(\theta_0)}\right) \cdot e^{j \cdot \left(\phi l(\xi) - \frac{w}{i} \cdot 2 \cdot \pi + l \cdot \alpha\right)} + \left(1 - \frac{j}{b \cdot \sin(\theta_0)}\right) \cdot e^{-j \cdot \left(\phi l(\xi) - \frac{w}{i} \cdot 2 \cdot \pi + l \cdot \alpha\right)}$$

(dimensionless)

$$C\phi(\xi, \phi, l) := \left[ \left(1 + \frac{j}{b \cdot \sin(\theta_0)}\right) \cdot e^{j \cdot (\phi l(\xi) - \phi + l \cdot \alpha)} - \left(1 - \frac{j}{b \cdot \sin(\theta_0)}\right) \cdot e^{-j \cdot (\phi l(\xi) - \phi + l \cdot \alpha)} \right] \cdot j \cdot \frac{\sin(\theta_0)}{2}$$

(dimensionless)

$$C1\phi(\xi, w, l) := \left[ \left(1 + \frac{j}{b \cdot \sin(\theta_0)}\right) \cdot e^{j \cdot \left(\phi l(\xi) - \frac{w}{i} \cdot 2 \cdot \pi + l \cdot \alpha\right)} - \left(1 - \frac{j}{b \cdot \sin(\theta_0)}\right) \cdot e^{-j \cdot \left(\phi l(\xi) - \frac{w}{i} \cdot 2 \cdot \pi + l \cdot \alpha\right)} \right] \cdot j \cdot \frac{\sin(\theta_0)}{2}$$

(dimensionless)

$$A(\xi, \theta, \phi) := \sum_1 e^{-j \cdot M \cdot l \cdot \alpha} \cdot e^{\frac{j \cdot k \cdot \xi}{Q} \cdot (\sin(\theta) \cdot \sin(\theta_0) \cdot \cos(\phi l(\xi) - \phi + l \cdot \alpha))} \cdot \left( \frac{\sin(\theta_0) \cdot \cos(\theta) \cdot C\theta(\xi, \phi, l)}{2} - \sin(\theta) \cdot \cos(\theta_0) \right)$$

(dimensionless)

$$D1(\xi, v, w) := \left( \frac{\sin(\theta_0) \cdot \cos\left(\frac{v}{i} \cdot \pi + \frac{\pi}{2}\right) \cdot C1\theta(\xi, w, l)}{2} - \sin\left(\frac{v}{i} \cdot \pi + \frac{\pi}{2}\right) \cdot \cos(\theta_0) \right)$$

(dimensionless)

$$A1(\xi, v, w) := \sum_1 e^{-j \cdot M \cdot l \cdot \alpha} \cdot e^{\frac{j \cdot k \cdot \xi}{Q} \cdot \left( \sin\left(\frac{v}{i} \cdot \pi + \frac{\pi}{2}\right) \cdot \sin(\theta_0) \cdot \cos\left(\phi l(\xi) - \frac{w}{i} \cdot 2 \cdot \pi + l \cdot \alpha\right) \right)} \cdot D1(\xi, v, w)$$

(dimensionless)

$$B(\xi, \theta, \phi) := \sum_1 e^{-j \cdot M \cdot l \cdot \alpha} \cdot e^{\frac{j \cdot k \cdot \xi}{Q} \cdot \sin(\theta) \cdot \sin(\theta_0) \cdot \cos(\phi l(\xi) - \phi + l \cdot \alpha)} \cdot C\phi(\xi, \phi, l)$$

(dimensionless)

$$B1(\xi, v, w) = \sum_1 e^{-j \cdot M \cdot l \cdot \alpha} \cdot e^{\frac{j \cdot k \cdot \xi}{Q} \cdot \sin\left(\frac{v}{i} \cdot \pi + \frac{\pi}{2}\right)} \cdot \sin(\theta_0) \cdot \cos\left(\phi l(\xi) - \frac{w}{i} \cdot 2 \cdot \pi + l \cdot \alpha\right) \cdot C1\phi(\xi, \phi, l)$$

(dimensionless)

Electric Field Components  $E_\theta$ ,  $E_\phi$ :

$$E_\theta(\theta, \phi) = -j \cdot f \cdot \mu_0 \cdot \frac{e^{-j \cdot k \cdot r_{ff}}}{2 \cdot r_{ff} \cdot Q} \int_0^L I(\xi) \cdot e^{\frac{j \cdot k \cdot \xi}{Q} \cdot \cos(\theta) \cdot \cos(\theta_0)} \cdot A(\xi, \theta, \phi) \, d\xi \quad (\text{V/m})$$

$$E_{\theta 1, w} = -j \cdot f \cdot \mu_0 \cdot \frac{e^{-j \cdot k \cdot r_{ff}}}{2 \cdot r_{ff} \cdot Q} \int_0^L I(\xi) \cdot e^{\frac{j \cdot k \cdot \xi}{Q} \cdot \cos\left(\frac{v}{i} \cdot \pi + \frac{\pi}{2}\right) \cdot \cos(\theta_0)} \cdot A1(\xi, v, w) \, d\xi \quad (\text{V/m})$$

$$E_\phi(\theta, \phi) = f \cdot \mu_0 \cdot \frac{e^{-j \cdot k \cdot r_{ff}}}{2 \cdot r_{ff} \cdot Q} \int_0^L I(\xi) \cdot e^{\frac{j \cdot k \cdot \xi}{Q} \cdot \cos(\theta) \cdot \cos(\theta_0)} \cdot B(\xi, \theta, \phi) \, d\xi \quad (\text{V/m})$$

$$E_{\phi 1, w} = f \cdot \mu_0 \cdot \frac{e^{-j \cdot k \cdot r_{ff}}}{2 \cdot r_{ff} \cdot Q} \int_0^L I(\xi) \cdot e^{\frac{j \cdot k \cdot \xi}{Q} \cdot \cos\left(\frac{v}{i} \cdot \pi + \frac{\pi}{2}\right) \cdot \cos(\theta_0)} \cdot B1(\xi, v, w) \, d\xi \quad (\text{V/m})$$

Radiation Intensity U( $\theta$ ):

$$U_2(\theta, \phi) := \frac{r^2 \eta_0^2}{2 \cdot \eta_0} \cdot [ (|E_\theta(\theta, \phi)|)^2 + (|E_\phi(\theta, \phi)|)^2 ] \quad (\text{W / solid angle})$$

$$U_{22}_{v,w} := \frac{r^2 \eta_0^2}{2 \cdot \eta_0} \cdot [ (|E_{\theta 1_{v,w}}|)^2 + (|E_{\phi 1_{v,w}}|)^2 ] \quad (\text{W / solid angle})$$

$$U_{\max} = \max(U_{22}) \quad (\text{W / solid angle})$$

$$U_{\max} = 0.25969 \quad (\text{W / solid angle})$$

Radiated Power P<sub>rad</sub>:

$$P_{\text{rad}} := \int_0^{2 \cdot \pi} \int_0^\pi U_2(\theta, \phi) \cdot \sin(\theta) \, d\theta \, d\phi \quad (\text{W})$$

$$P_{\text{rad}} = 0.81332 \quad (\text{W})$$

Directivity D<sub>0</sub>:

$$D_0 = \frac{4 \cdot \pi \cdot U_{\max}}{P_{\text{rad}}} \quad (\text{dimensionless})$$

$$D_0 = 4.01237 \quad (\text{dimensionless})$$

$$D_{\text{dbo}} := 10 \cdot \log(D_0) \quad (\text{dB})$$

$$D_{\text{dbo}} = 6.03401 \quad (\text{dB})$$

$$D_{1\text{dbo}} := \frac{32600}{\text{HPBW}^2} \quad (\text{dB})$$

$$D_{1\text{dbo}} = 5.09375 \quad (\text{dB})$$

Voltage Reflection Coefficient  $\Gamma$ :

$$\Gamma = \frac{Z_i - Z_o}{Z_i + Z_o} \quad (\text{dimensionless})$$

$$\Gamma = 0.23077 \quad (\text{dimensionless})$$

Reflection Efficiency  $\epsilon_{rv}$ :

$$\epsilon_{rv} = 1 - (|\Gamma|)^2 \quad (\text{dimensionless})$$

$$\epsilon_{rv} = 0.94675 \quad (\text{dimensionless})$$

Gain G:

$$G = \epsilon_{rv} \cdot D_o \quad (\text{dimensionless})$$

$$G = 3.7987 \quad (\text{dimensionless})$$

$$G_{dB} = 10 \cdot \log(G) \quad (\text{dB})$$

$$G_{dB} = 5.79635 \quad (\text{dB})$$

Effective Isotropic Radiated Power (EIRP):

$$\text{EIRP} = \text{Prad} \cdot D_o \quad (\text{W})$$

$$\text{EIRP} = 3.26336 \quad (\text{W})$$

Polarization Loss Factor PLF:

$$\theta_p = \text{atan}\left(\frac{\sqrt{x^2 + y^2}}{z}\right) \quad (\text{radians}) \quad \phi_p = \text{atan}\left(\frac{y}{x}\right) \quad (\text{radians})$$

$$\theta_p = 0 \quad (\text{radians}) \quad \phi_p = 0 \quad (\text{radians})$$

$$E_x := E\theta(\theta_p, \phi_p) \cdot \cos(\theta_p) \cdot \cos(\phi_p) - E\phi(\theta_p, \phi_p) \cdot \sin(\phi_p) \quad (\text{V/m})$$

$$E_y := E\theta(\theta_p, \phi_p) \cdot \cos(\theta_p) \cdot \sin(\phi_p) - E\phi(\theta_p, \phi_p) \cdot \cos(\phi_p) \quad (\text{V/m})$$

$$E_z := -E\theta(\theta_p, \phi_p) \cdot \sin(\theta_p) \quad (\text{V/m})$$

$$\sigma_a := \frac{1}{\sqrt{(|E_x|)^2 + (|E_y|)^2 + (|E_z|)^2}} \cdot \begin{pmatrix} E_x \\ E_y \\ E_z \end{pmatrix} \quad (\text{dimensionless})$$

$$\sigma_a = \begin{pmatrix} -0.92973 - 0.1613j \\ 0.29553 + 0.14919j \\ 0 \end{pmatrix} \quad (\text{dimensionless})$$

$$\text{PLF} = \left( |\sigma_w \cdot \sigma_a| \right)^2 \quad (\text{dimensionless})$$

$$\text{PLF} = 0.40896 \quad (\text{dimensionless})$$

Maximum Effective Aperture ( $A_{em}$ ):

$$A_{em} := \frac{\lambda^2 \cdot D_o \cdot \sigma_v \cdot \text{PLF}}{4 \cdot \pi} \quad (\text{m}^2)$$

$$A_{em} = 0.14172 \quad (\text{m}^2)$$

Maximum Effective Height ( $h_{em}$ ):

$$h_{em} = \sqrt{\frac{R_r \cdot A_{em}}{\eta_0}} \cdot 2 \quad (\text{m})$$

$$h_{em} = 4.88816 \cdot 10^{-3} \quad (\text{m})$$

THE CONICAL LOG-SPIRAL ANTENNA FAR-FIELD ELEVATION PATTERNS

For the purpose of the far-field radiation elevation patterns, the conical log-spiral antenna lies parallel to the  $E_y = 0$  grid line. Application users must specify the desired azimuth and elevation for the plots.

THETA COMPONENT OF THE ELEVATION PATTERN

$$\phi_g := \frac{\pi}{2} \quad (\text{radians})$$

$$E_x(\theta) := |E\theta(\theta + \pi, \phi_g)| \cdot \cos\left(\theta + \frac{\pi}{2}\right) \quad E_y(\theta) := |E\theta(\theta + \pi, \phi_g)| \cdot \sin\left(\theta + \frac{\pi}{2}\right)$$

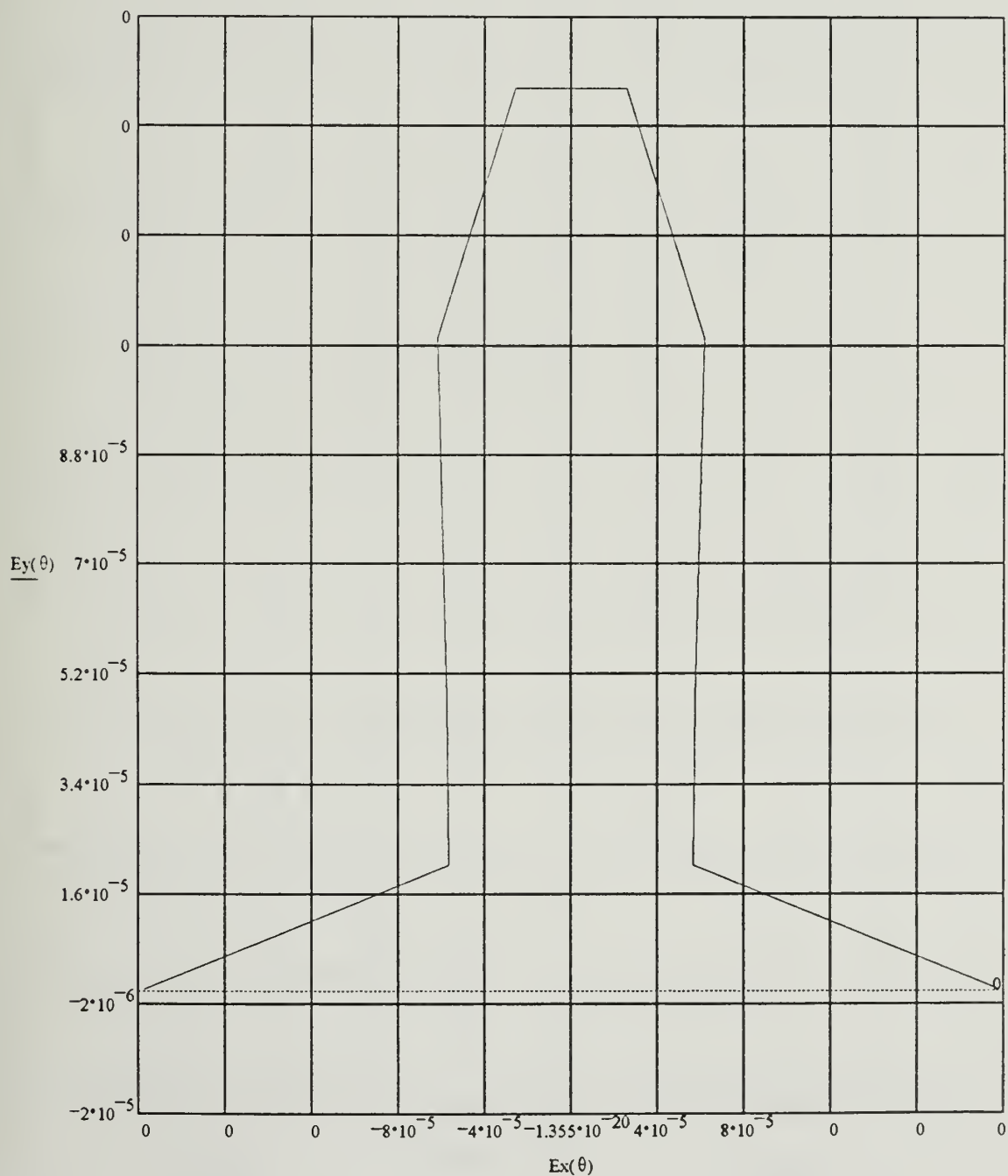

— E FIELD

PHI COMPONENT OF THE ELEVATION PATTERN

$$\phi_g = \frac{\pi}{2} \quad (\text{radians})$$

$$Ex1(\theta) := |E\phi(\theta + \pi, \phi_g)| \cdot \cos\left(\theta + \frac{\pi}{2}\right) \quad Ey1(\theta) := |E\phi(\theta + \pi, \phi_g)| \cdot \sin\left(\theta + \frac{\pi}{2}\right)$$

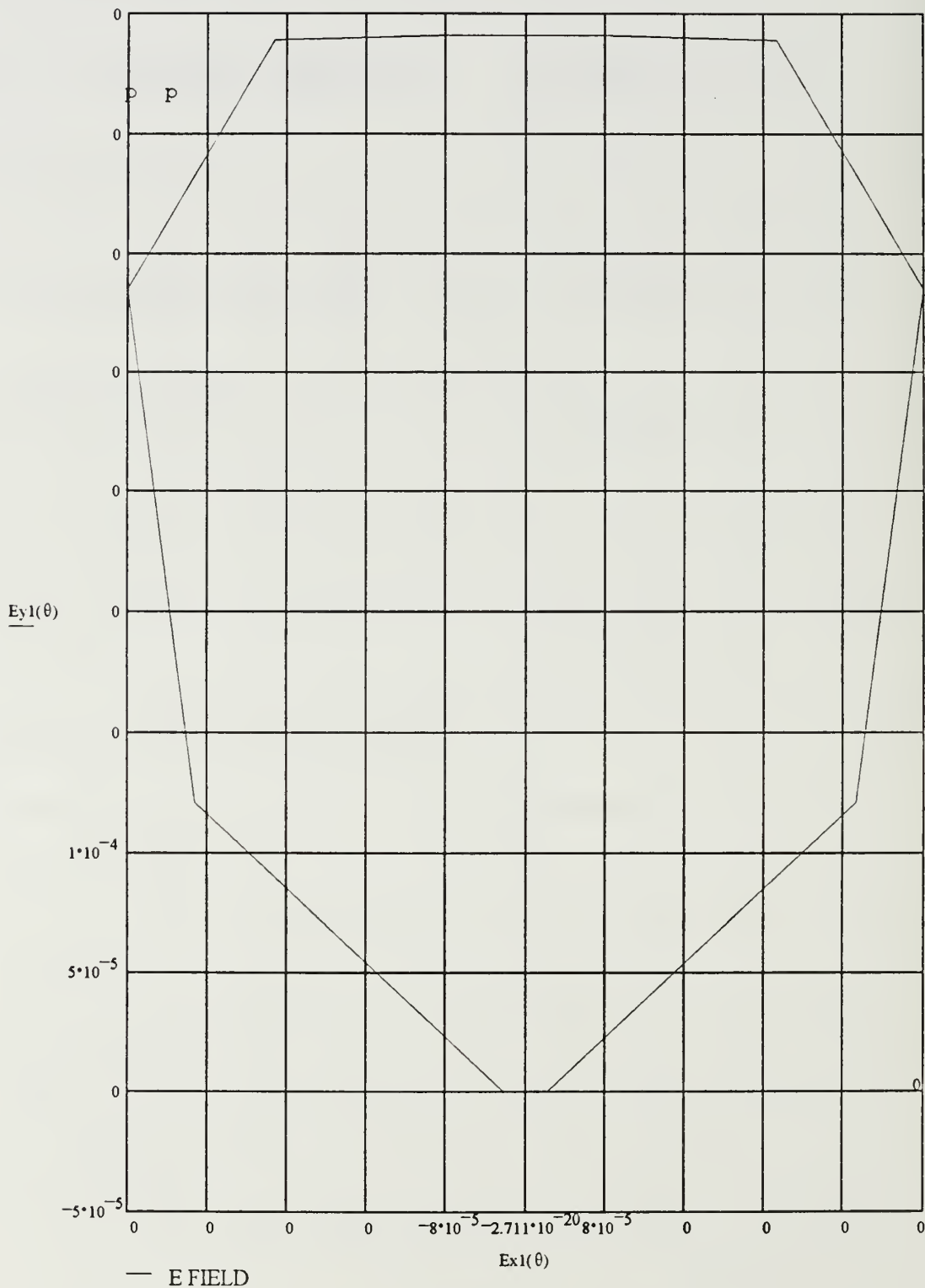

TOTAL ELEVATION PATTERN

$$\phi_g = \frac{\pi}{2} \quad (\text{radians})$$

$$E_t(\theta, \phi) = \sqrt{E_\theta(\theta, \phi)^2 + E_\phi(\theta, \phi)^2}$$

$$E_{x2}(\theta) = |E_t(\theta + \pi, \phi_g)| \cdot \cos\left(\theta + \frac{\pi}{2}\right) \quad E_{y2}(\theta) = |E_t(\theta + \pi, \phi_g)| \cdot \sin\left(\theta + \frac{\pi}{2}\right)$$

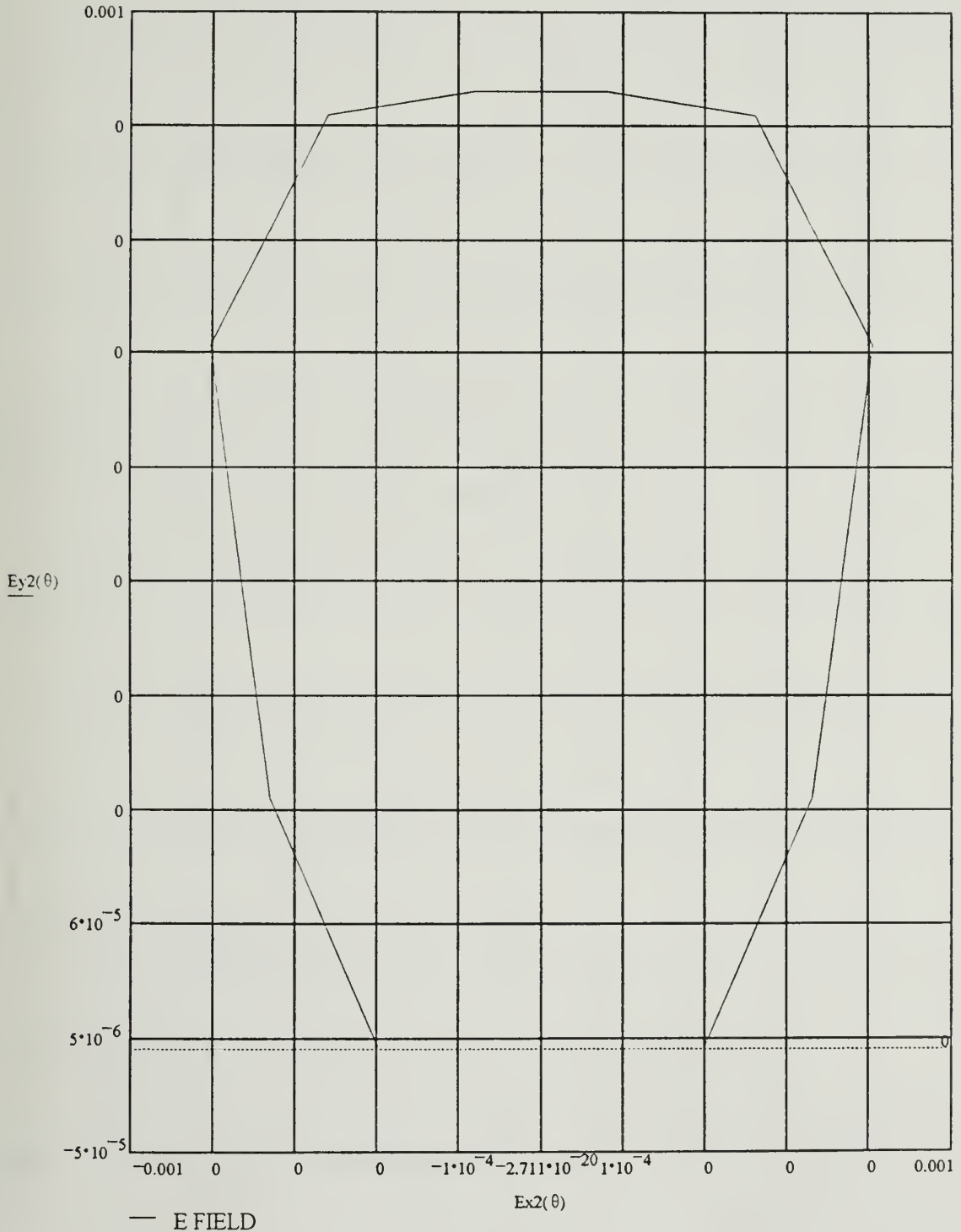



For the purpose of the far-field radiation azimuth patterns, the conical log-spiral antenna lies in the plane of the plot and is centered at the origin. Application users must specify the desired offset angle from the z axis for the plots.

THETA COMPONENT OF THE AZIMUTH PATTERN

$$\theta_g = \frac{\pi}{9} \quad (\text{radians})$$

$$E_x(\phi) = |E\theta(\theta_g, \phi)| \cdot \cos(\phi)$$

$$E_y(\phi) = |E\theta(\theta_g, \phi)| \cdot \sin(\phi)$$

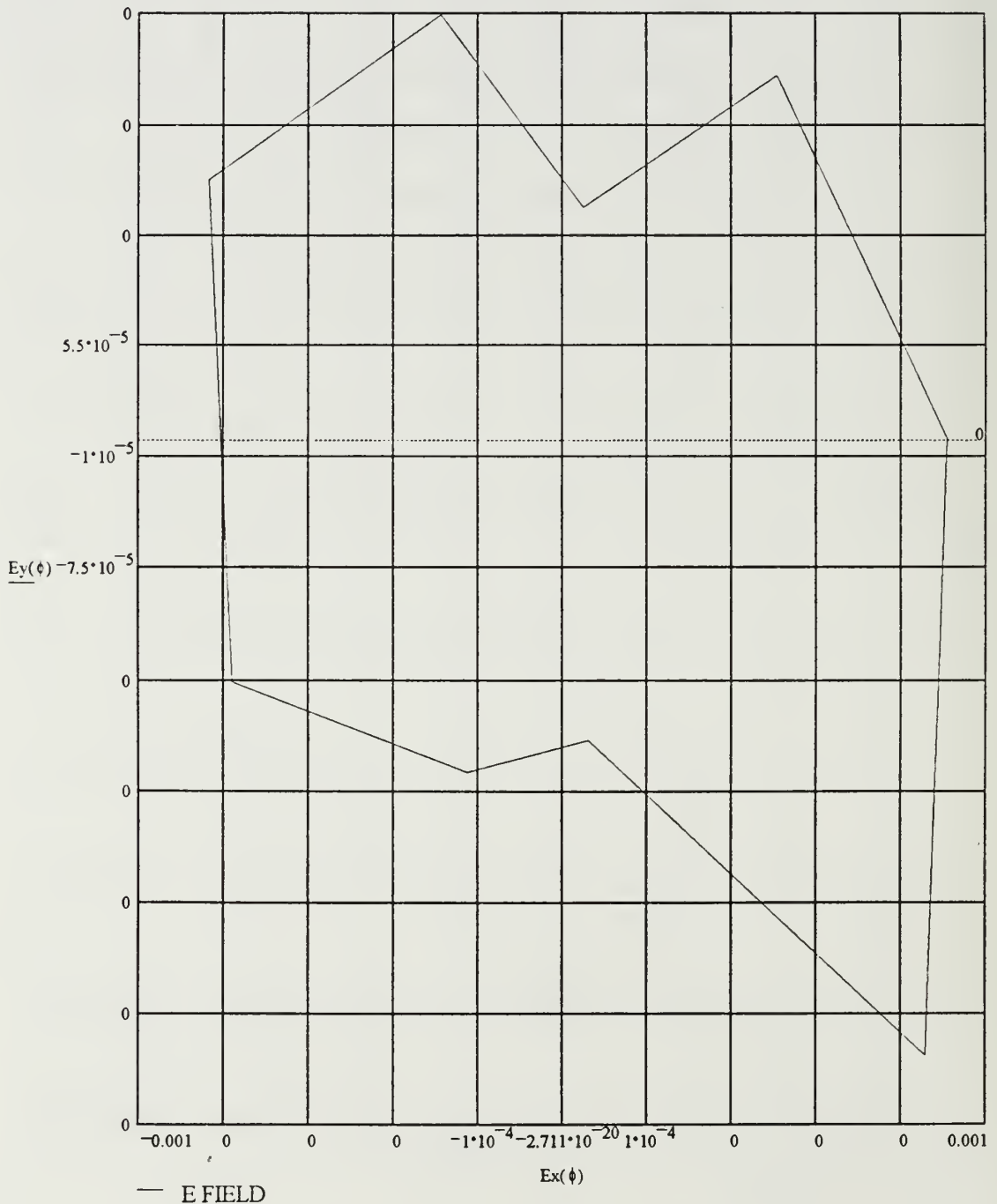

$$Ex1(\phi) := |E\phi(\theta_g, \phi)| \cdot \cos(\phi)$$

$$Ey1(\phi) := |E\phi(\theta_g, \phi)| \cdot \sin(\phi)$$

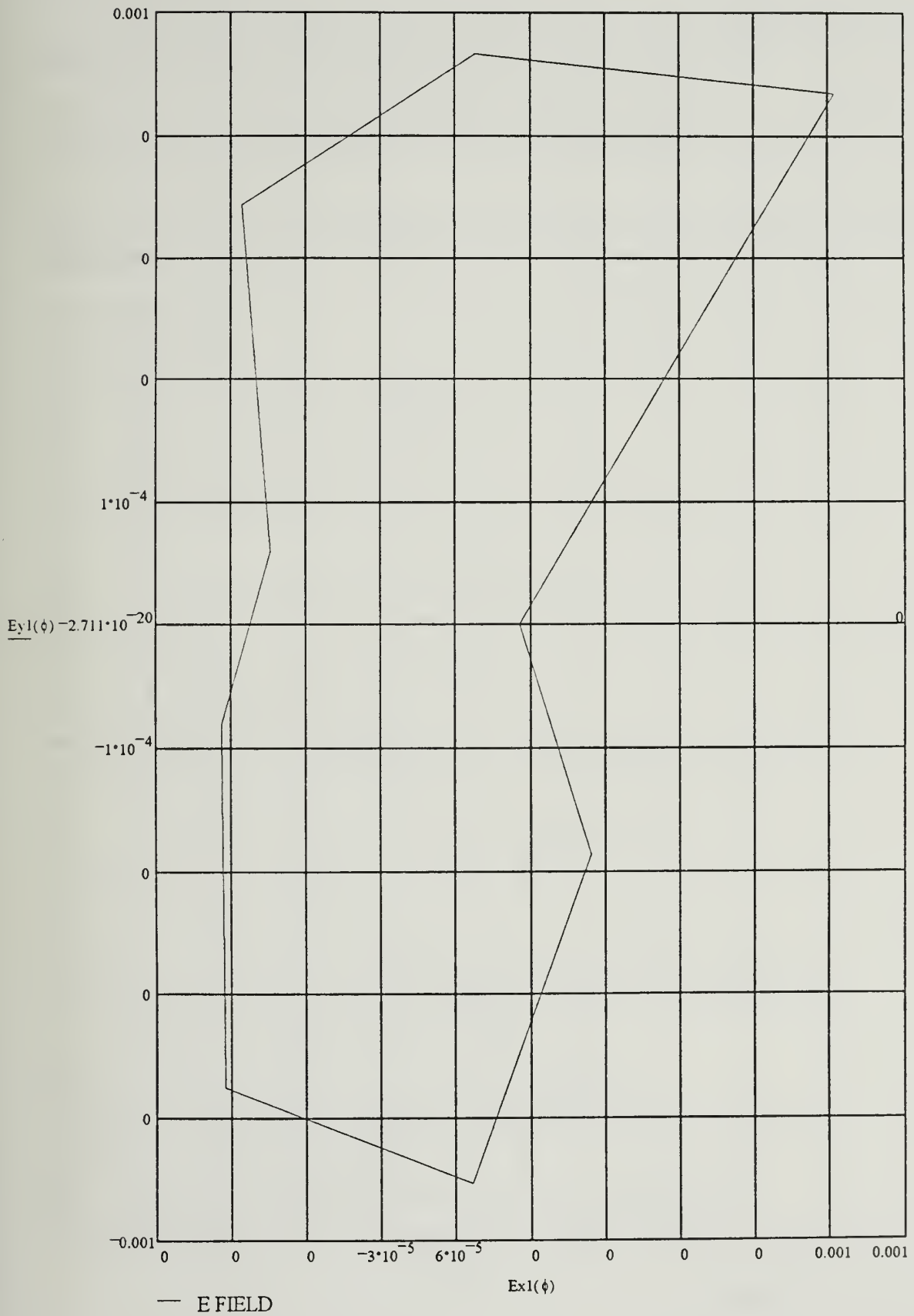

TOTAL AZIMUTH PATTERN

$$Ex2(\phi) = |Et(\theta_g, \phi)| \cdot \cos(\phi)$$

$$Ey2(\phi) = |Et(\theta_g, \phi)| \cdot \sin(\phi)$$

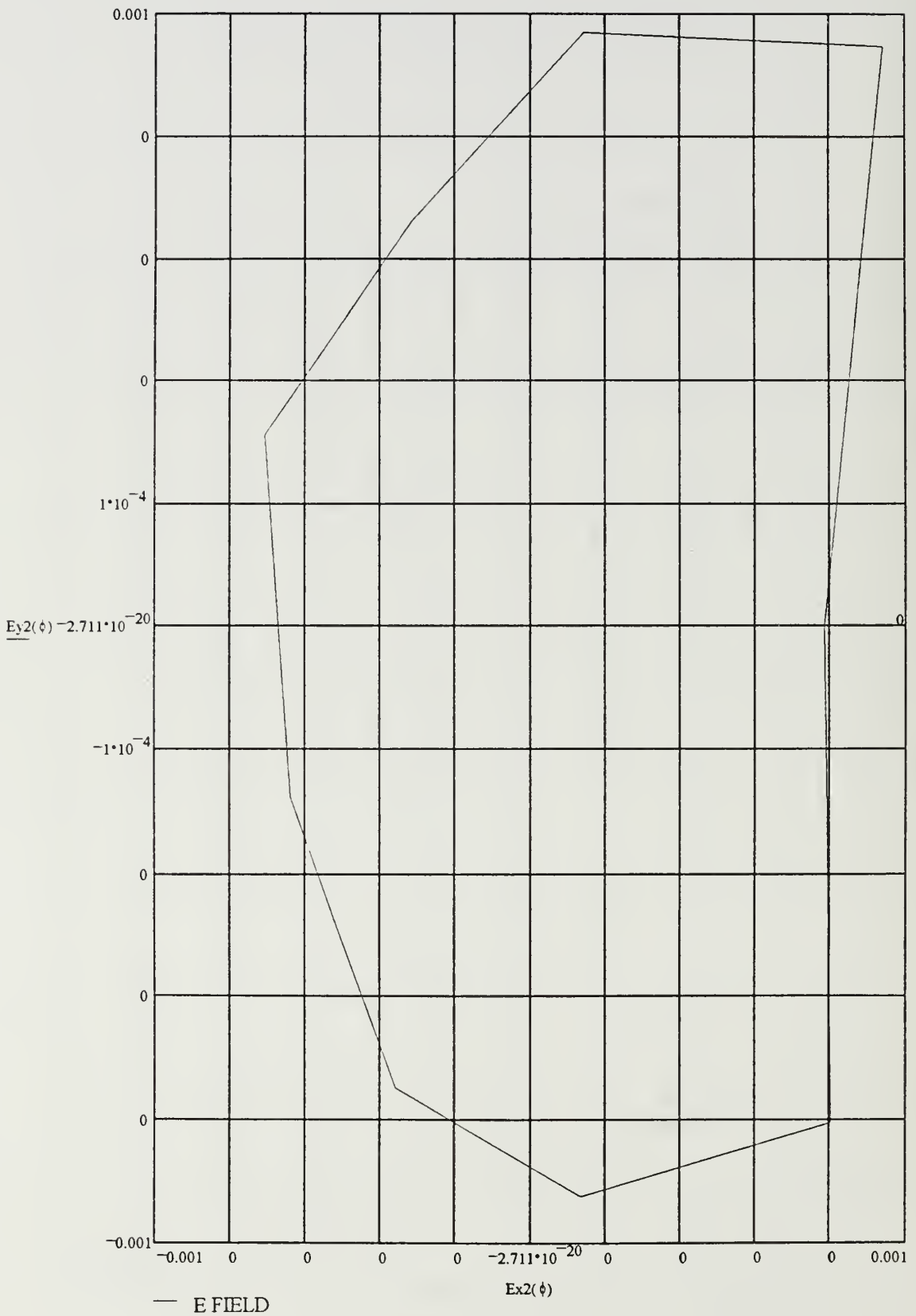

Conical horn antennas are devices used to provide a transition from a circular waveguide to an unbounded medium such that the wavefront at the aperture of the horn has nearly a constant phase at any point in the mouth of the horn.

Conical horns are commonly used as feed elements for reflectors used in satellite tracking, microwave communications, and radar.

(Note: Mathcad equations cannot use symbolic subscripts. Therefore, symbols like  $\lambda$  will immediately follow the parameter in equations in lieu of subscripts.)

The conical horn antenna Mathcad applications will compute the following parameters:

k = Wavenumber  
 $\lambda$  = Wavelength  
 $D_0$  = Directivity  
 $E_\theta$  = Electric Field ( $\theta$ ) Component  
 $E_\phi$  = Electric Field ( $\phi$ ) Component  
U = Radiation Intensity  
 $U_{max}$  = Maximum Radiation Intensity  
 $P_{rad}$  = Radiated Power  
G = Gain  
EIRP = Effective Isotropic Radiated Power  
 $A_{em}$  = Maximum Effective Aperture  
BW = Bandwidth  
 $r_{min}$  = Minimum Distance to Far-Field  
 $R_r$  = Radiation Resistance  
 $h_{em}$  = Maximum Effective Height  
 $E_{x,y,z}$  = Electric Field Components in Cartesian Coordinates  
 $\sigma_a$  = Unit Polarization Vector  
 $f_{cte}$  = Transverse Electric Cutoff Frequencies  
 $f_{ctm}$  = Transverse Magnetic Cutoff Frequencies  
 $\epsilon_{ap}$  = Aperture Efficiency  
PLF = Polarization Loss Factor  
 $P_v(\cos(\theta))$  = Associated Legendre Function of the First Kind  
 $H^{(2)}_v, H^{(2)}_v'$  = Spherical Hankel Function and its Derivative  
v = Legendre and Hankel Function Order  
 $b_0, \delta$  = Legendre and Hankel Function Constants  
 $d_{optimum}$  = Optimum Conical Horn Mouth Diameter  
 $A_{x,y,z}$  = Conical Horn Magnetic Vector Potentials  
h = Conical Horn Axial Height  
 $B_H$  = Magnetic Vector Potential Integral Coefficients  
 $\beta$  = Magnetic Vector Potential Integral Phase Shift

The following data must be input based on known or estimated data:

$m, n$  = Mode

$f$  = Frequency of Interest

$i$  = Number of Increments for Far Field Radiation Patterns

$r_{ff}$  = Distance of Far-Field Calculations

$I_0$  = Input Current at Antenna Terminals

$\theta_g$  = Coaltitude (Deflection Angle from +z Axis) for Azimuth Plot

$\phi_g$  = Azimuth Angle for Elevation Plot

$(x, y, z)$  = Coordinates for Unit Polarization Vector

$\alpha$  = Flare Angle

$a$  = Circular Waveguide Inner Radius

$\chi_{m,n}$  =  $n^{\text{th}}$  Zero of Bessel Function of the First Kind, Order  $m$ .

$\chi'_{m,n}$  =  $n^{\text{th}}$  Zero of Bessel Function Derivative of the First Kind, Order  $m$ .

$B_0$  = Electric Field Amplitude Constant

$d_{\text{meas}}$  = Measured Diameter of the Conical Horn's Mouth

---

Enter input data here:

$n = 1$  (mode number)

$f = 1.96 \cdot 10^9$  (Hz)

$m = 1$  (mode number)

$I_0 = 1$  (amps)

$i = 18$  (increments)

$r_{ff} = 1 \cdot 10^2$  (meters)

$a = .0445$  (m)

$\alpha = 2 \cdot \frac{\pi}{9}$  (radians)

$\sigma_w = \begin{bmatrix} 1 \\ \sqrt{2} \\ j \\ \sqrt{2} \\ 0 \end{bmatrix}$  (dimensionless)

(Note:  $\alpha$  must be less than  $\pi/3$ )

$x = 10^3$  (m)

$B_0 = 1$  (V/m)

$y = 10^3$  (m)

$d_{\text{meas}} = 1$  (m)

$z = 10^3$  (m)

Calculate conical horn antenna geometric parameters and define constants:

$$c = 2.9979 \cdot 10^8 \quad (\text{meters/sec})$$

$$\eta_0 = 120 \cdot \pi \quad (\Omega)$$

$$\lambda = \frac{c}{f} \quad (\text{meters/cycle})$$

$$\epsilon_0 = \frac{1}{36 \cdot \pi} \cdot 10^{-9} \quad (\text{Farads/m})$$

$$\lambda = 0.15295 \quad (\text{meters/cycle})$$

$$\mu_0 = 4 \cdot \pi \cdot 10^{-7} \quad (\text{H/m})$$

$$d_{\text{optimum}} = \frac{3}{2} \cdot \lambda \cdot \frac{1}{\sin\left(\frac{\alpha}{2}\right)} \quad (\text{m})$$

$$h = \frac{\frac{d_{\text{meas}}}{2}}{\text{atan}\left(\frac{\alpha}{2}\right)} \quad (\text{m})$$

$$d_{\text{optimum}} = 0.67081 \quad (\text{m})$$

$$h = 1.48879 \quad (\text{m})$$

Define Bessel Function Matrices:

(Note: m = column number, n = row number, matrix index starts at n = m = 0. The n = 0 row has no physical significance, it is only a placeholder.)

$$\chi = \begin{bmatrix} 0 & 0 & 0 & 0 & 0 \\ 2.4049 & 3.8318 & 5.1357 & 6.3802 & 7.5884 \\ 5.5201 & 7.1056 & 8.4173 & 9.7610 & 11.0647 \\ 8.6537 & 10.1735 & 11.6199 & 13.0152 & 14.3726 \\ 11.7915 & 13.3227 & 14.7960 & 16.2235 & 17.6160 \end{bmatrix} \quad (\text{dimensionless})$$

$$\chi_p = \begin{bmatrix} 0 & 0 & 0 & 0 & 0 \\ 3.8318 & 1.8412 & 3.0542 & 4.2012 & 5.3175 \\ 7.0156 & 5.3315 & 6.7062 & 8.0153 & 9.2824 \\ 10.1735 & 8.5363 & 9.9695 & 11.3459 & 12.6819 \\ 13.3237 & 11.7060 & 13.1704 & 14.5859 & 15.9641 \end{bmatrix} \quad (\text{dimensionless})$$

Calculate planar spiral antenna parameters :

Define angular offset  $\theta$   
from y-z axis:

Distance to Far-Field  $r_{min}$ :

$$\theta_p = -\frac{a}{2}, \frac{a}{2}, -\frac{a}{2}, \frac{a}{2} \quad (\text{radians})$$

$$r_0 = 1.6 \cdot \lambda \quad (\text{m})$$

$$r_1 = 5 \cdot d_{meas} \quad (\text{m})$$

$$\phi_p = 0, \frac{2 \cdot \pi}{i}, \dots, 2 \cdot \pi \quad (\text{radians})$$

$$r_2 = \frac{2 \cdot d_{meas}^2}{\lambda} \quad (\text{m})$$

$$\theta = -\frac{\pi}{2}, \frac{\pi}{2}, -\frac{\pi}{2}, \frac{\pi}{2} \quad (\text{radians})$$

$$r_{min} = \max(r_i) \quad (\text{m})$$

$$\phi = 0, \frac{2 \cdot \pi}{i}, \dots, 2 \cdot \pi \quad (\text{radians})$$

$$r_{min} = 13.07582 \quad (\text{m})$$

Wavenumber  $k$ :

$$k = \frac{2 \cdot \pi}{\lambda} \quad (\text{m}^{-1})$$

$$k = 41.0789 \quad (\text{m}^{-1})$$

Cutoff Frequencies  $f_c$ :

Transverse Electric (TE) Modes

$$f_{cte} = \frac{\mathcal{P}}{2 \cdot \pi \cdot a \cdot \sqrt{\mu_0 \cdot \epsilon_0}} \quad (\text{Hz})$$

$$f_{cte} = \begin{bmatrix} 0 & 0 & 0 & 0 & 0 \\ 4.11135 \cdot 10^9 & 1.97552 \cdot 10^9 & 3.27702 \cdot 10^9 & 4.5077 \cdot 10^9 & 5.70544 \cdot 10^9 \\ 7.52742 \cdot 10^9 & 5.72046 \cdot 10^9 & 7.19545 \cdot 10^9 & 8.60005 \cdot 10^9 & 9.95959 \cdot 10^9 \\ 1.09157 \cdot 10^{10} & 9.15906 \cdot 10^9 & 1.06968 \cdot 10^{10} & 1.21736 \cdot 10^{10} & 1.36071 \cdot 10^{10} \\ 1.42957 \cdot 10^{10} & 1.256 \cdot 10^{10} & 1.41312 \cdot 10^{10} & 1.565 \cdot 10^{10} & 1.71288 \cdot 10^{10} \end{bmatrix} \quad (\text{Hz})$$

Transverse Magnetic (TM) Modes

$$f_{ctm} = \frac{\lambda}{2 \cdot \pi \cdot a \cdot \sqrt{\mu_0 \cdot \epsilon_0}} \quad (\text{Hz})$$

$$f_{ctm} = \begin{bmatrix} 0 & 0 & 0 & 0 & 0 \\ 2.58035 \cdot 10^9 & 4.11135 \cdot 10^9 & 5.51037 \cdot 10^9 & 6.84567 \cdot 10^9 & 8.14201 \cdot 10^9 \\ 5.92282 \cdot 10^9 & 7.62399 \cdot 10^9 & 9.03138 \cdot 10^9 & 1.04731 \cdot 10^{10} & 1.18719 \cdot 10^{10} \\ 9.28503 \cdot 10^9 & 1.09157 \cdot 10^{10} & 1.24676 \cdot 10^{10} & 1.39647 \cdot 10^{10} & 1.54211 \cdot 10^{10} \\ 1.26517 \cdot 10^{10} & 1.42947 \cdot 10^{10} & 1.58754 \cdot 10^{10} & 1.74071 \cdot 10^{10} & 1.89012 \cdot 10^{10} \end{bmatrix} \quad (\text{Hz})$$

Legendre and Hankel Function Constants  $b_0, \delta$ :

$$b_0 = \frac{\log\left(\frac{1 - \frac{\alpha}{\pi}}{4}\right)}{\log\left(\cos\left(\frac{\alpha}{2}\right)\right)} \quad (\text{dimensionless})$$

$$b_0 = 26.32708 \quad (\text{dimensionless})$$

$$\delta = \frac{\pi}{\alpha} \quad (\text{dimensionless})$$

$$\delta = 4.5 \quad (\text{dimensionless})$$

Legendre and Hankel Function Orders  $\nu$ :

$$\nu = -.5 + .5 \cdot \sqrt{1 + 4 \cdot b_0} \quad (\text{dimensionless})$$

$$\nu = 4.6553 \quad (\text{dimensionless})$$



Legendre Functions  $P_{\nu} \cos(\theta)$  :

$$P_1(\theta) = \frac{\Gamma(\nu+2)}{\Gamma(\nu+1.5)} \cdot \sqrt{\frac{\pi}{2}} \cdot \sin(\theta) \cdot \cos\left[(\nu+0.5)\theta + \frac{\pi}{4}\right] \quad (\text{dimensionless})$$

$$P_1\left(\frac{\alpha}{2}\right) = -1.51294 \quad (\text{dimensionless})$$

Hankel Function and its Derivative  $H_{\nu}^{(2)}$ ,  $H_{\nu}^{(2)'} :$

$$H_{\nu 2} = \frac{1}{k \cdot h} \cdot e^{-j \cdot \left(k \cdot h - \frac{\nu+1}{2} \cdot \pi\right)} \quad (\text{dimensionless})$$

$$H_{\nu 2p} = \frac{1}{k \cdot h} \cdot e^{-j \cdot \left(k \cdot h - \frac{\nu}{2} \cdot \pi\right)} \cdot \left(1 - j \cdot \frac{\nu+1}{k \cdot h}\right) \quad (\text{dimensionless})$$

Magnetic Vector Potential Integral Coefficient  $B_H :$

$$B_H = \frac{B_0 \cdot h^2}{j \cdot (2 \cdot \pi)^2 \cdot f \cdot \epsilon_0 \cdot rff} \cdot e^{-j \cdot k \cdot rff} \cdot \left(\frac{1}{h} \cdot H_{\nu 2} + k \cdot H_{\nu 2p}\right) \quad (\text{Wb/m})$$

Magnetic Vector Potential Integral Phase Shift  $\beta$  and Other Coefficients:

$$\beta(\theta, \phi, \theta_p, \phi_p) = \cos(\theta) \cdot \cos(\theta_p) + \sin(\theta) \cdot \sin(\theta_p) \cdot \cos(\phi - \phi_p) \quad (\text{dimensionless})$$

$$C(\theta_p, \phi_p) = \left(\sin(\delta \cdot \theta_p) \cdot \cos(\phi_p)\right)^2 \cdot \cos(\theta_p) + \delta \cdot \cos(\delta \cdot \theta_p) \cdot \sin(\phi_p)^2 \cdot \sin(\theta_p) \quad (\text{dimensionless})$$

$$D(\theta_p, \phi_p) = \sin(\delta \cdot \theta_p) \cdot \cos(\phi_p) \cdot \sin(\phi_p) \cdot \cos(\theta_p) - \delta \cdot \cos(\delta \cdot \theta_p) \cdot \sin(\phi_p) \cdot \cos(\phi_p) \cdot \sin(\theta_p)$$

## Magnetic Vector Potential Integrals :

$$A_x(\theta, \phi) := -BH \cdot pl \left( \frac{a}{2} \right) \cdot \int_0^{\frac{a}{2}} \int_0^{2\pi} e^{j \cdot k \cdot h \cdot \beta(\theta, \phi, \theta_p, \phi_p)} \cdot C(\theta_p, \phi_p) \, d\phi_p \, d\theta_p \quad (\text{Wb/m})$$

$$A_y(\theta, \phi) := -BH \cdot pl \left( \frac{a}{2} \right) \cdot \int_0^{\frac{a}{2}} \int_0^{2\pi} e^{j \cdot k \cdot h \cdot \beta(\theta, \phi, \theta_p, \phi_p)} \cdot D(\theta_p, \phi_p) \, d\phi_p \, d\theta_p \quad (\text{Wb/m})$$

$$A_z(\theta, \phi) := -BH \cdot pl \left( \frac{a}{2} \right) \cdot \int_0^{\frac{a}{2}} \int_0^{2\pi} e^{j \cdot k \cdot h \cdot \beta(\theta, \phi, \theta_p, \phi_p)} \cdot \sin(\delta \cdot \theta_p) \cdot \cos(\phi_p) \cdot \sin(\theta_p) \, d\phi_p \, d\theta_p \quad (\text{Wb/m})$$

## Electric Field Components $E_\theta, E_\phi$ :

$$E_\theta(\theta, \phi) = k^2 \cdot (A_x(\theta, \phi) \cdot \cos(\theta) \cdot \cos(\phi) + A_y(\theta, \phi) \cdot \cos(\theta) \cdot \sin(\phi) - A_z(\theta, \phi) \cdot \sin(\theta)) \quad (\text{V/m})$$

$$E_\phi(\theta, \phi) := -A_x(\theta, \phi) \cdot \sin(\phi) + A_y(\theta, \phi) \cdot \cos(\phi) \quad (\text{V/m})$$

## Radiation Intensity $U(\theta)$ :

$$U(\theta, \phi) := \frac{rff^2}{2 \cdot \eta_0} \cdot [ (|E_\theta(\theta, \phi)|)^2 + (|E_\phi(\theta, \phi)|)^2 ] \quad (\text{W/solid angle})$$

Radiated Power  $P_{\text{rad}}$ :

$$P_{\text{rad}} = \int_0^{2\pi} \int_0^{\frac{\pi}{2}} U(\theta, \phi) \cdot \sin(\theta) \, d\theta \, d\phi \quad (\text{W})$$

$$P_{\text{rad}} = 8.23092 \cdot 10^2 \quad (\text{W})$$

Directivity  $D_0$ :

$$D_0 = \frac{4 \cdot \pi \cdot U(0,0)}{P_{\text{rad}}} \quad (\text{dimensionless})$$

$$D_0 = 2.33662 \cdot 10^2 \quad (\text{dimensionless})$$

Radiation Resistance  $R_r$ :

$$R_r = \frac{2 \cdot P_{\text{rad}}}{(|I_0|)^2} \quad (\Omega)$$

$$R_r = 1.64618 \cdot 10^3 \quad (\Omega)$$

Gain  $G$ :

$$G = .95 \cdot D_0 \quad (\text{dimensionless})$$

$$G = 2.21979 \cdot 10^2 \quad (\text{dimensionless})$$

$$G_{\text{dB}} = 10 \cdot \log(G) \quad (\text{dB})$$

$$G_{\text{dB}} = 23.46311 \quad (\text{dB})$$

Effective Isotropic Radiated Power EIRP:

EIRP := Prad·Do (W)

EIRP = 1.92325·10<sup>5</sup> (W)

Antenna Unit Polarization Vector  $\sigma_a$  :

$\theta_{p1} := \text{atan}\left(\frac{\sqrt{x^2 + y^2}}{z}\right)$  (radians)       $\phi_{p1} := \text{atan}\left(\frac{y}{x}\right)$  (radians)

$\theta_{p1} = 0.95532$  (radians)       $\phi_{p1} = 0.7854$  (radians)

$E_x := E\theta(\theta_{p1}, \phi_{p1}) \cdot \cos(\theta_{p1}) \cdot \cos(\phi_{p1}) - E\phi(\theta_{p1}, \phi_{p1}) \cdot \sin(\phi_{p1})$  (V/m)

$E_y := E\theta(\theta_{p1}, \phi_{p1}) \cdot \cos(\theta_{p1}) \cdot \sin(\phi_{p1}) + E\phi(\theta_{p1}, \phi_{p1}) \cdot \cos(\phi_{p1})$  (V/m)

$E_z := -E\theta(\theta_{p1}, \phi_{p1}) \cdot \sin(\theta_{p1})$  (V/m)

$\sigma_a = \frac{1}{\sqrt{(|E_x|)^2 + (|E_y|)^2 + (|E_z|)^2}} \cdot \begin{pmatrix} E_x \\ E_y \\ E_z \end{pmatrix}$  (dimensionless)

$\sigma_a = \begin{pmatrix} 0.05346 + 0.40449j \\ 0.05361 + 0.40495j \\ -0.10708 - 0.80945j \end{pmatrix}$  (dimensionless)

Polarization Loss Factor PLF:

$PLF := \left( \left| \frac{\sigma_w}{\sigma_a} \right| \right)^2$  (dimensionless)

PLF = 0.16663 (dimensionless)

Maximum Effective Aperture ( $A_{em}$ ):

$$A_{em} = \frac{\lambda^2 \cdot Do \cdot 95 \cdot PLF}{4 \cdot \pi} \quad (m^2)$$

$$A_{em} = 0.06886 \quad (m^2)$$

Maximum Effective Height ( $h_{em}$ ):

$$h_{em} = \sqrt{\frac{Rr \cdot A_{em}}{\eta_0}} \cdot 2 \quad (m)$$

$$h_{em} = 1.09672 \quad (m)$$

Aperture Efficiency  $\epsilon_{ap}$ :

$$\epsilon_{ap} = \frac{A_{em}}{\pi \cdot \left(\frac{d_{meas}}{2}\right)^2} \quad (\text{dimensionless})$$

$$\epsilon_{ap} = 0.08768 \quad (\text{dimensionless})$$

For the purpose of these far-field radiation patterns, the conical horn antenna axis is parallel to the  $E_y = 0$  grid line and the apex of the horn is located at the origin. Electric field components behind the horn's aperture are assumed to be zero.

Theta Component of Elevation Pattern

$$\phi_g = \frac{\pi}{2} \quad (\text{radians})$$

$$E_{\theta x}(\theta) = |E_{\theta}(\theta, \phi_g)| \cdot \cos(\theta)$$

$$E_{\theta y}(\theta) = |E_{\theta}(\theta, \phi_g)| \cdot \sin(\theta)$$

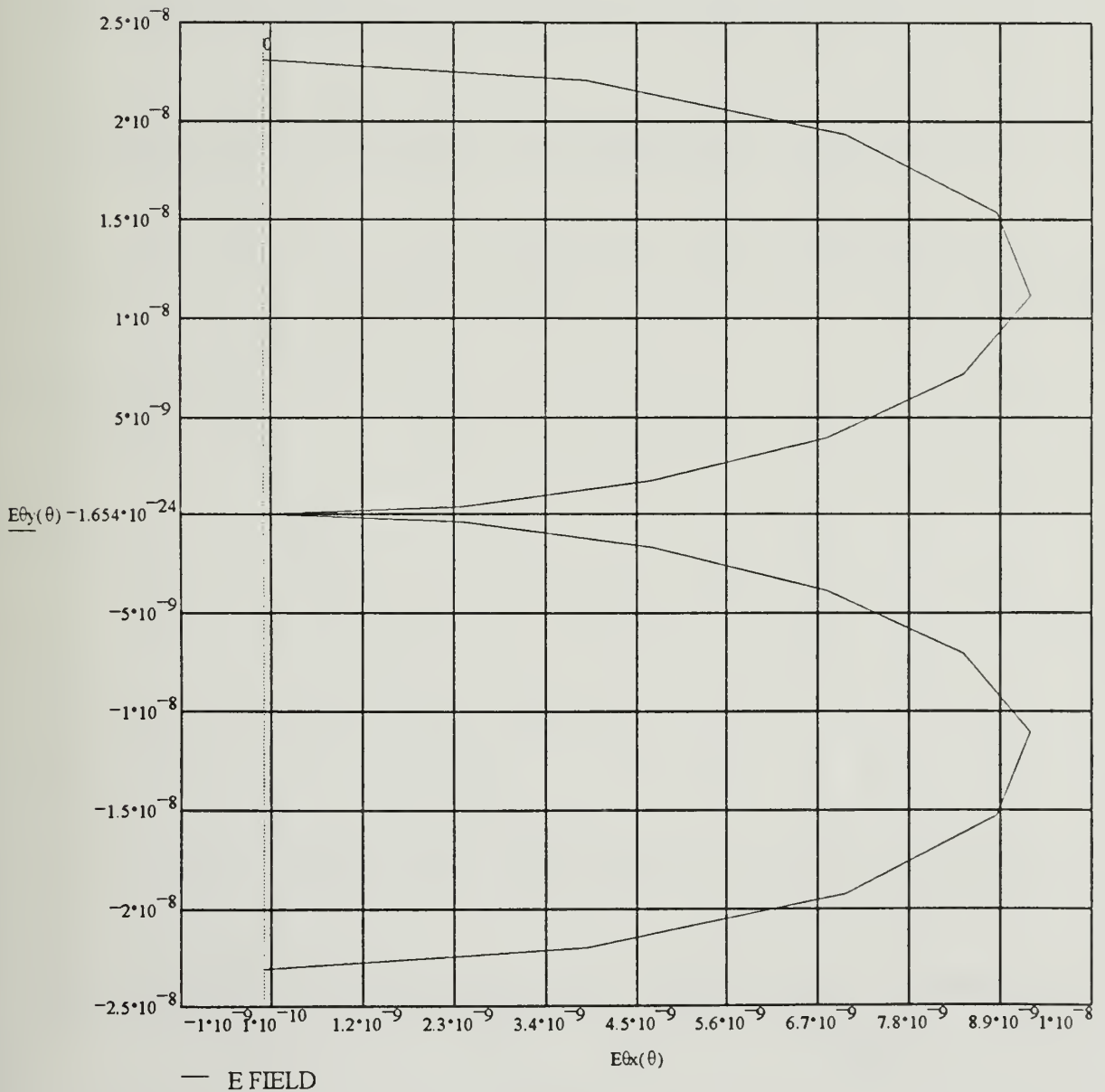

Phi Component of Elevation Pattern

$$E_{\phi x}(\theta) := |E_{\phi}(\theta, \phi_g)| \cdot \cos(\theta)$$

$$E_{\phi y}(\theta) := |E_{\phi}(\theta, \phi_g)| \cdot \sin(\theta)$$

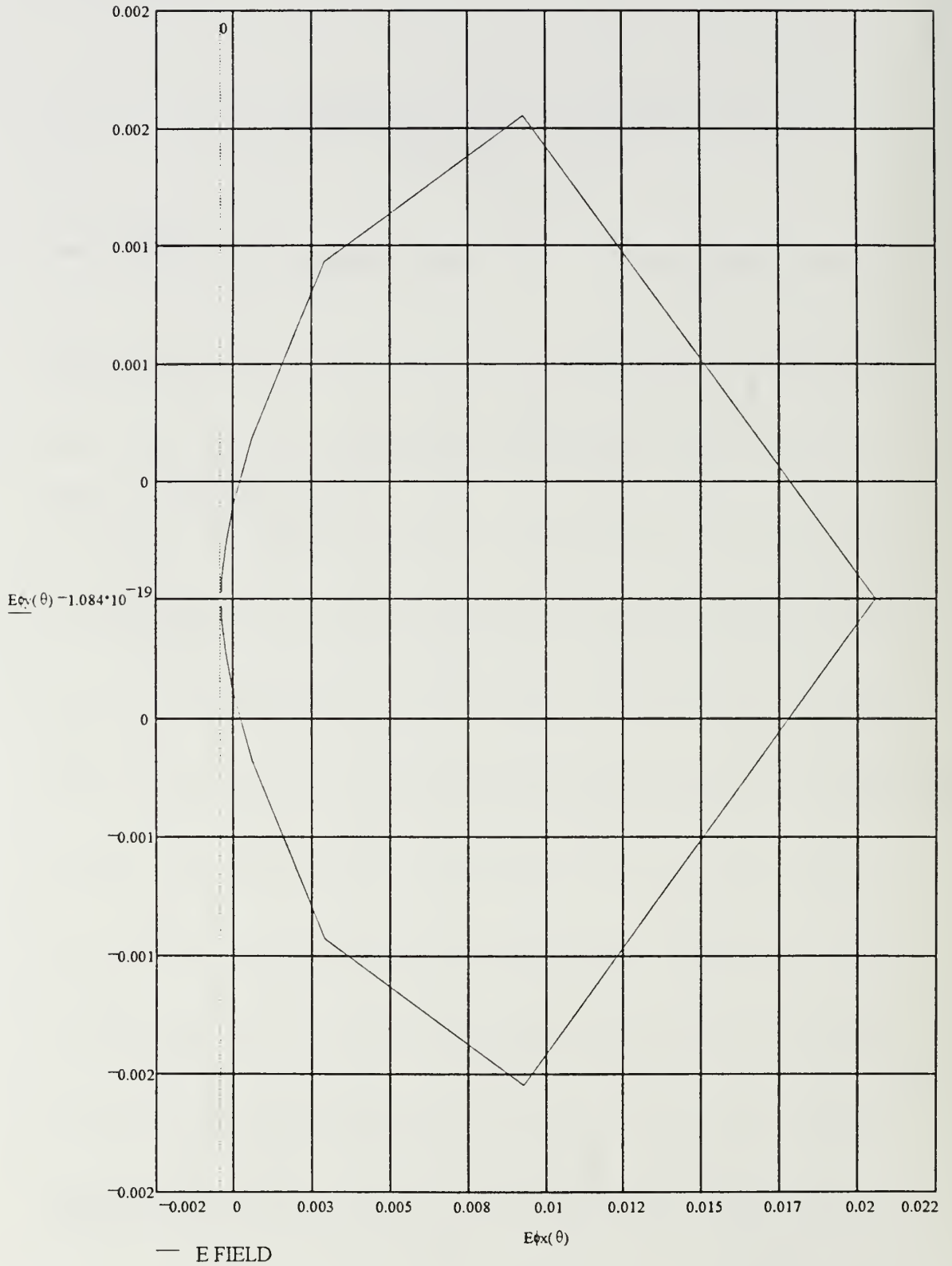

Total Elevation Pattern

$$Et(\theta, \phi) := \sqrt{E\theta(\theta, \phi)^2 + E\phi(\theta, \phi)^2}$$

$$Et_x(\theta) := |Et(\theta, \phi_g)| \cdot \cos(\theta)$$

$$Et_y(\theta) := |Et(\theta, \phi_g)| \cdot \sin(\theta)$$

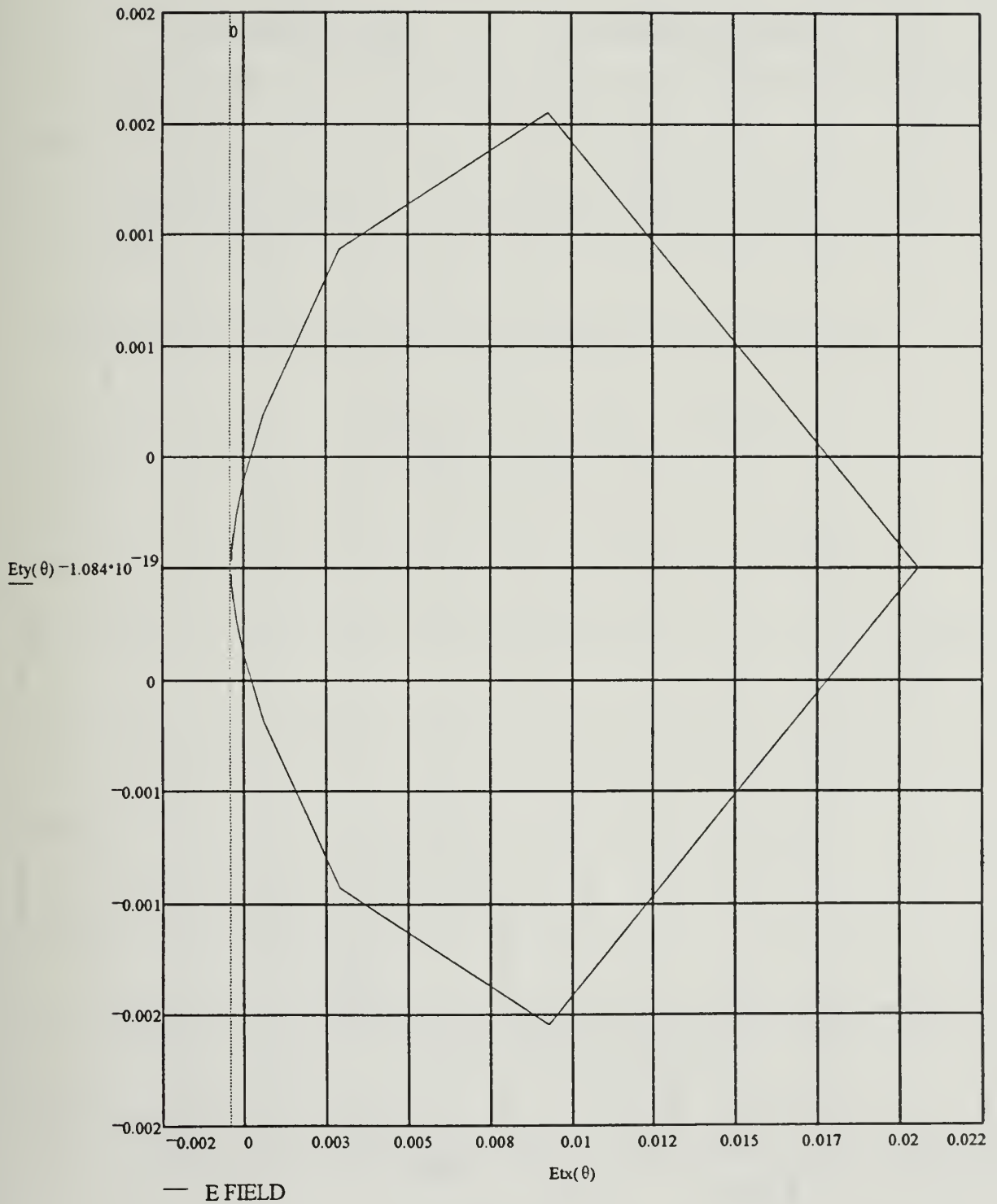



For the purpose of these far-field radiation patterns, the conical horn antenna axis is perpendicular to the  $E_y = 0$  and  $E_x = 0$  grid lines and the apex of the horn is located at the origin.

Theta Component of Azimuth Pattern

$\theta_g := \frac{\pi}{10}$  (Note:  $\theta_g$  must be less than  $a/2$  radians)

$E\theta_x(\phi) := |E\theta(\theta_g, \phi)| \cdot \cos(\phi)$

$E\theta_y(\phi) := |E\theta(\theta_g, \phi)| \cdot \sin(\phi)$

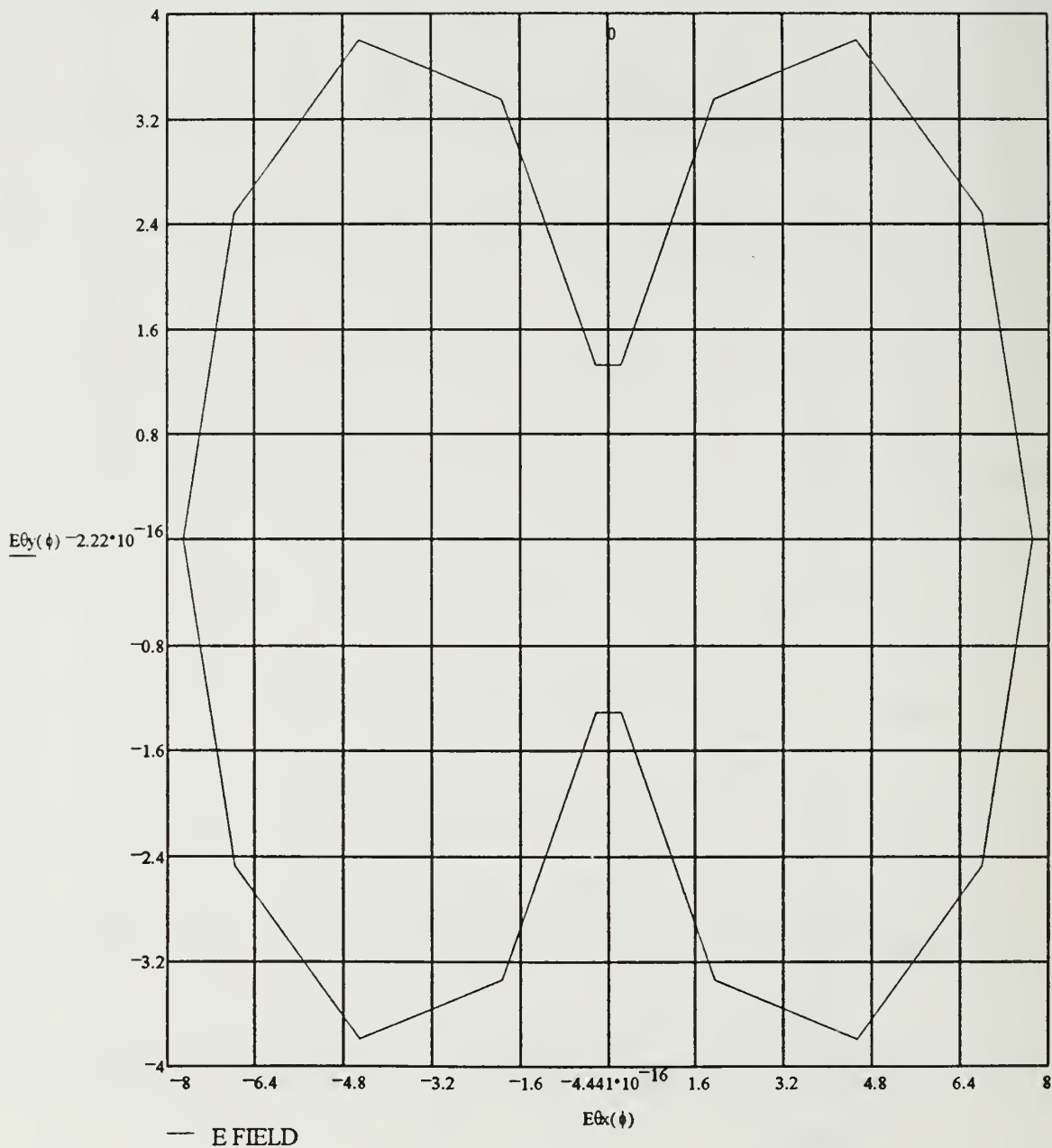

Phi Component of Azimuth Pattern

$$E_{\phi x}(\phi) := |E_{\phi}(\theta_g, \phi)| \cdot \cos(\phi)$$

$$E_{\phi y}(\phi) := |E_{\phi}(\theta_g, \phi)| \cdot \sin(\phi)$$

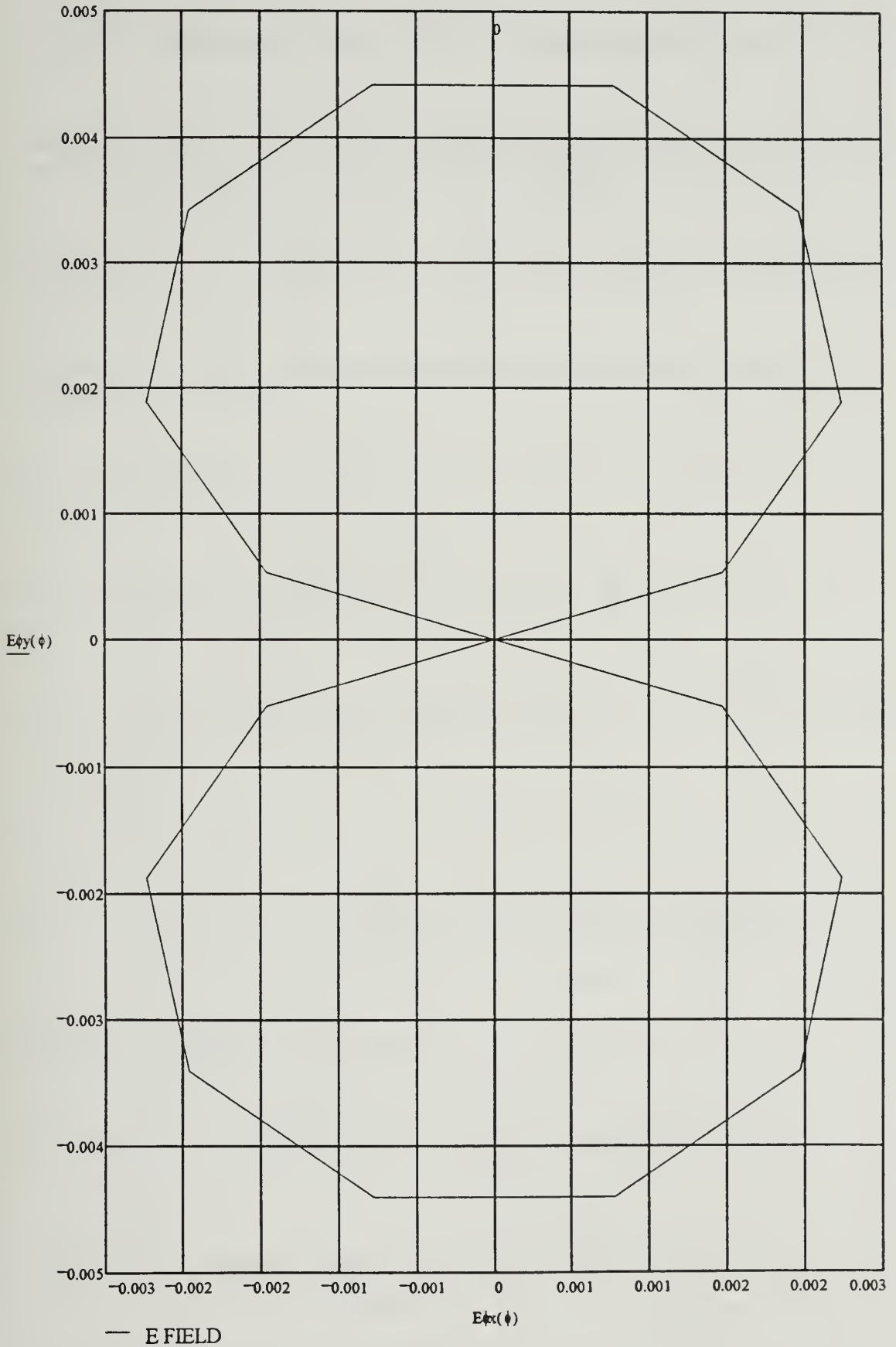

Total Azimuth Pattern

$$E_t(\theta, \phi) := \sqrt{E_\theta(\theta, \phi)^2 + E_\phi(\theta, \phi)^2}$$

$$E_{tx}(\phi) := |E_t(\theta, \phi)| \cdot \cos(\phi)$$

$$E_{ty}(\phi) := |E_t(\theta, \phi)| \cdot \sin(\phi)$$

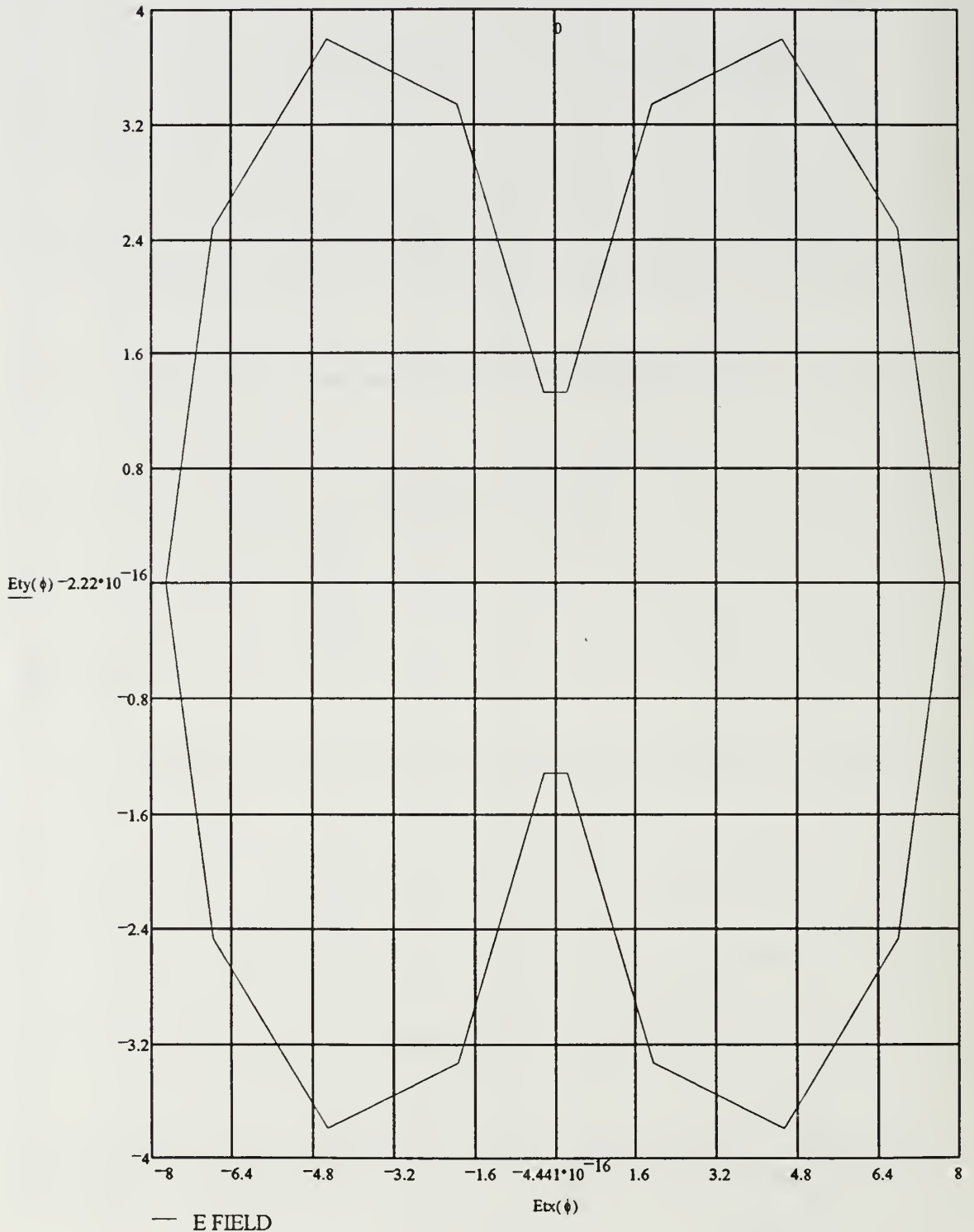

Pyramidal horn antennas are devices used to provide a transition from a rectangular waveguide to an unbounded medium such that the wavefront at the aperture of the horn has nearly a constant phase at any point in the mouth of the horn.

Pyramidal horns are the most popular type of feed elements for reflectors used in satellite tracking, microwave communications, and radar.

The pyramidal horn applications may be used to analyze E- and H-plane sectoral horns. To analyze an E-plane sectoral horn set horn dimension (a1) equal to waveguide dimension (a). To analyze an H-plane sectoral horn set horn dimension (b1) equal to waveguide dimension (b).

(Note: Mathcad equations cannot use symbolic subscripts. Therefore, symbols like  $\lambda$  will immediately follow the parameter in equations in lieu of subscripts.)

The pyramidal horn antenna Mathcad applications will compute the following parameters:

k = Wavenumber  
 $\lambda$  = Wavelength  
 $D_0$  = Directivity  
 $E_\theta$  = Electric Field ( $\theta$ ) Component  
 $E_\phi$  = Electric Field ( $\phi$ ) Component  
U = Radiation Intensity  
 $U_{max}$  = Maximum Radiation Intensity  
 $P_{rad}$  = Radiated Power  
G = Gain  
EIRP = Effective Isotropic Radiated Power  
 $A_{em}$  = Maximum Effective Aperture  
BW = Bandwidth  
 $r_{min}$  = Minimum Distance to Far-Field  
 $R_r$  = Radiation Resistance  
 $h_{em}$  = Maximum Effective Height  
 $E_{x,y,z}$  = Electric Field Components in Cartesian Coordinates  
 $\sigma_a$  = Unit Polarization Vector  
 $f_c$  = Transverse Electric and Transverse Magnetic Cutoff Frequencies  
 $\epsilon_{ap}$  = Aperture Efficiency  
PLF = Polarization Loss Factor  
 $D_p$  = Pyramidal Horn Corner to Corner Distance  
 $P_{e,h}$  = Pyramidal Horn Perpendicular Flare to Mouth Distances  
 $I_{1,2}$  = Electric Field Component Equation Coefficients

The following data must be input based on known or estimated data:

$t$  = Number of Cutoff Frequencies Calculated

$m, n$  = Modes

$f$  = Frequency of Interest

$i$  = Number of Increments for Far Field Radiation Patterns

$r_{ff}$  = Distance of Far-Field Calculations

$I_0$  = Input Current at Antenna Terminals

$\theta_g$  = Coaltitude (Deflection Angle from +z Axis) for Azimuth Plot

$\phi_g$  = Azimuth Angle for Elevation Plot

$(x, y, z)$  = Coordinates for Unit Polarization Vector

$a, b$  = Rectangular Waveguide Dimensions

$a_1, b_1$  = Pyramidal Horn Dimensions

$\rho_1, \rho_2, \rho_e, \rho_h$  = Pyramidal Horn Imaginary Cone Apex to Mouth Distances

$E_0$  = Electric Field Amplitude Constant

Enter input data here:

$t := 5$  (modes)  $f := 9.3 \cdot 10^9$  (Hz)  
 $i := 36$  (increments)  $I_0 := 1$  (amps)  
 $rff := 1 \cdot 10^2$  (meters)

(Note: For E-plane sectoral horn analysis  
set (a1) equal to (a). For H-plane sectoral  
horn analysis set (b1) equal to (a))

$a := .02286$  (m)  $\sigma_w := \begin{bmatrix} 1 \\ \sqrt{2} \\ j \\ \sqrt{2} \\ 0 \end{bmatrix}$  (dimensionless)  
 $a1 := .1846$  (m)  
 $b := .01016$  (m)  $\rho1 := .3398$  (m)  
 $b1 := .1455$  (m)  $\rho2 := .3198$  (m)  
 $\rho_e := .3281$  (m)  $x := 10^3$  (m)  
 $\rho_h := .3521$  (m)  $y := 10^3$  (m)  
 $E_0 := 1$  (V/m)  $z := 10^3$  (m)

Calculate pyramidal horn antenna geometric parameters and define constants:

$$c := 2.9979 \cdot 10^8 \quad (\text{meters/sec})$$

$$\eta_0 := 120 \cdot \pi \quad (\Omega)$$

$$\lambda := \frac{c}{f} \quad (\text{meters/cycle})$$

$$\epsilon_0 := \frac{1}{36 \cdot \pi} \cdot 10^{-9} \quad (\text{Farads/m})$$

$$\lambda = 0.03224 \quad (\text{meters/cycle})$$

$$\mu_0 := 4 \cdot \pi \cdot 10^{-7} \quad (\text{H/m})$$

$$D_p := \sqrt{a^2 + b^2} \quad (\text{m})$$

$$D_p = 0.23505 \quad (\text{m})$$

$$p_e := (b_1 - b) \cdot \sqrt{\left(\frac{p_e}{b_1}\right)^2 - \frac{1}{4}} \quad (\text{m})$$

$$p_h := (a_1 - a) \cdot \sqrt{\left(\frac{p_h}{a_1}\right)^2 - \frac{1}{4}} \quad (\text{m})$$

$$p_e = 0.29759 \quad (\text{m})$$

$$p_h = 0.29771 \quad (\text{m})$$

Calculate planar spiral antenna parameters :

Define angular offset  $\theta$   
from y-z axis:

Distance to Far-Field  $r_{\min}$ :

$$\theta := -\frac{\pi}{2i} + \frac{\pi}{2} + 10^{-6} \dots \frac{\pi}{2} + 10^{-6} \quad (\text{radians})$$

$$r_0 := 1.6 \cdot \lambda \quad (\text{m})$$

$$r_1 := 5 \cdot D_p \quad (\text{m})$$

$$r_2 := \frac{2 \cdot D_p^2}{\lambda} \quad (\text{m})$$

$$\phi := 10^{-6} + \frac{2 \cdot \pi}{i} + 10^{-6} \dots 2 \cdot \pi + 10^{-6} \quad (\text{radians})$$

$$r_{\min} := \max(r_r) \quad (\text{m})$$

$$r_{\min} = 3.42774 \quad (\text{m})$$

Wavenumber k:

$$k := \frac{2 \cdot \pi}{\lambda} \quad (\text{m}^{-1})$$

$$k = 1.94915 \cdot 10^2 \quad (\text{m}^{-1})$$

Cutoff Frequencies  $f_c$ :

$$n := 0..t \quad (\text{modes})$$

$$m := 0..t \quad (\text{modes})$$

$$f_{c,m,n} = \frac{1}{2 \cdot \sqrt{\mu_0 \cdot \epsilon_0}} \cdot \sqrt{\left(\frac{m}{a}\right)^2 + \left(\frac{n}{b}\right)^2} \quad (\text{Hz})$$

$f_c =$	0	$1.47638 \cdot 10^{10}$	$2.95276 \cdot 10^{10}$	$4.42913 \cdot 10^{10}$	$5.90551 \cdot 10^{10}$	$7.38189 \cdot 10^{10}$
	$6.56168 \cdot 10^9$	$1.61563 \cdot 10^{10}$	$3.02478 \cdot 10^{10}$	$4.47748 \cdot 10^{10}$	$5.94185 \cdot 10^{10}$	$7.411 \cdot 10^{10}$
	$1.31234 \cdot 10^{10}$	$1.97533 \cdot 10^{10}$	$3.23125 \cdot 10^{10}$	$4.61946 \cdot 10^{10}$	$6.04957 \cdot 10^{10}$	$7.49763 \cdot 10^{10}$
	$1.9685 \cdot 10^{10}$	$2.46063 \cdot 10^{10}$	$3.54877 \cdot 10^{10}$	$4.84688 \cdot 10^{10}$	$6.22496 \cdot 10^{10}$	$7.63985 \cdot 10^{10} \text{ (Hz)}$
	$2.62467 \cdot 10^{10}$	$3.01141 \cdot 10^{10}$	$3.95065 \cdot 10^{10}$	$5.14841 \cdot 10^{10}$	$6.46251 \cdot 10^{10}$	$7.83462 \cdot 10^{10}$
	$3.28084 \cdot 10^{10}$	$3.59772 \cdot 10^{10}$	$4.41392 \cdot 10^{10}$	$5.51191 \cdot 10^{10}$	$6.75566 \cdot 10^{10}$	$8.07813 \cdot 10^{10}$

(Note: The index for both m,n above begins with zero. TM modes cannot have m or n equal zero.  $TE_{00}$  mode does not physically exist.)



Electric Field Component Coefficients  $I_1, I_2$ :

$v := 0..i$  (increments)

$w := 0..i$  (increments)

$$I1(\theta, \phi) := \int_{-\frac{a1}{2}}^{\frac{a1}{2}} \cos\left(\pi \cdot \frac{\xi}{2}\right) \cdot e^{-j \cdot k \cdot \left(\frac{\xi^2}{2 \cdot \rho2} - \sin(\theta) \cdot \cos(\phi) \cdot \xi\right)} d\xi \quad (\text{dimensionless})$$

$$I11_{v,w} := \int_{-\frac{a1}{2}}^{\frac{a1}{2}} \cos\left(\pi \cdot \frac{\xi}{2}\right) \cdot e^{-j \cdot k \cdot \left(\frac{\xi^2}{2 \cdot \rho2} - \sin\left(\frac{v}{i} \cdot \pi - \frac{\pi}{2}\right) \cdot \cos\left(\frac{w}{i} \cdot 2 \cdot \pi\right) \cdot \xi\right)} d\xi \quad (\text{dimensionless})$$

$$I1(\theta, \phi) := \text{if } a1 = a, -\pi \cdot \frac{a}{2} \cdot \left[ \frac{\cos\left(k \cdot \frac{a}{2} \cdot \sin(\theta) \cdot \cos(\phi)\right)}{\left(k \cdot \frac{a}{2} \cdot \sin(\theta) \cdot \cos(\phi)\right)^2 - \left(\frac{\pi}{2}\right)^2} \right], I1(\theta, \phi) \quad (\text{dimensionless})$$

$$I11_{v,w} := \text{if } a1 = a, -\pi \cdot \frac{a}{2} \cdot \left[ \frac{\cos\left(k \cdot \frac{a}{2} \cdot \sin\left(\frac{v}{i} \cdot \pi - \frac{\pi}{2} + 10^{-6}\right) \cdot \cos\left(\frac{w}{i} \cdot 2 \cdot \pi + 10^{-6}\right)\right)}{\left(k \cdot \frac{a}{2} \cdot \sin\left(\frac{v}{i} \cdot \pi - \frac{\pi}{2} + 10^{-6}\right) \cdot \cos\left(\frac{w}{i} \cdot 2 \cdot \pi + 10^{-6}\right)\right)^2 - \left(\frac{\pi}{2}\right)^2} \right], I11_{v,w} \quad (\text{dimensionless})$$

$$I2(\theta, \phi) := \int_{-\frac{b1}{2}}^{\frac{b1}{2}} e^{-j \cdot k \cdot \left(\frac{\xi^2}{2 \cdot \rho1} - \sin(\theta) \cdot \sin(\phi) \cdot \xi\right)} d\xi \quad (\text{dimensionless})$$

$$I21_{v,w} := \int_{-\frac{b1}{2}}^{\frac{b1}{2}} e^{-j \cdot k \cdot \left( \frac{\xi^2}{2 \cdot \rho1} - \sin\left(\frac{v}{i} \cdot \pi - \frac{\pi}{2}\right) \cdot \sin\left(\frac{w}{i} \cdot 2 \cdot \pi\right) \cdot \xi \right)} d\xi \quad (\text{dimensionless})$$

$$I2(\theta, \phi) := \text{if } b1=b, b \cdot \left[ \frac{\sin\left(k \cdot \frac{b}{2} \cdot \sin(\theta) \cdot \sin(\phi)\right)}{\left(k \cdot \frac{b}{2} \cdot \sin(\theta) \cdot \sin(\phi)\right)} \right], I2(\theta, \phi) \quad (\text{dimensionless})$$

$$I21_{v,w} := \text{if } b1=b, b \cdot \left[ \frac{\sin\left(k \cdot \frac{b}{2} \cdot \sin\left(\frac{v}{i} \cdot \pi - \frac{\pi}{2} + 10^{-6}\right) \cdot \sin\left(\frac{w}{i} \cdot 2 \cdot \pi + 10^{-6}\right)\right)}{\left(k \cdot \frac{b}{2} \cdot \sin\left(\frac{v}{i} \cdot \pi - \frac{\pi}{2} + 10^{-6}\right) \cdot \sin\left(\frac{w}{i} \cdot 2 \cdot \pi + 10^{-6}\right)\right)} \right], I21_{v,w} \quad (\text{dimensionless})$$

### Electric Field Components $E_\theta, E_\phi$ :

$$E\theta(\theta, \phi) := j \cdot k \cdot Eo \cdot \frac{e^{-j \cdot k \cdot rff}}{4 \cdot \pi \cdot rff} \cdot (\sin(\phi) \cdot (1 + \cos(\theta))) \cdot I1(\theta, \phi) \cdot I2(\theta, \phi) \quad (\text{V/m})$$

$$E\theta1_{v,w} := j \cdot k \cdot Eo \cdot \frac{e^{-j \cdot k \cdot rff}}{4 \cdot \pi \cdot rff} \cdot \left[ \sin\left(\frac{w}{i} \cdot 2 \cdot \pi\right) \cdot \left(1 + \cos\left(\frac{v}{i} \cdot \pi - \frac{\pi}{2}\right)\right) \cdot I11_{v,w} \cdot I21_{v,w} \right] \quad (\text{V/m})$$

$$E\phi(\theta, \phi) := j \cdot k \cdot Eo \cdot \frac{e^{-j \cdot k \cdot rff}}{4 \cdot \pi \cdot rff} \cdot (\cos(\phi) \cdot (1 + \cos(\theta))) \cdot I1(\theta, \phi) \cdot I2(\theta, \phi) \quad (\text{V/m})$$

$$E\phi1_{v,w} := j \cdot k \cdot Eo \cdot \frac{e^{-j \cdot k \cdot rff}}{4 \cdot \pi \cdot rff} \cdot \left[ \cos\left(\frac{w}{i} \cdot 2 \cdot \pi\right) \cdot \left(1 + \cos\left(\frac{v}{i} \cdot \pi - \frac{\pi}{2}\right)\right) \cdot I11_{v,w} \cdot I21_{v,w} \right] \quad (\text{V/m})$$

Radiation Intensity U(θ):

$$U(\theta, \phi) := \frac{r^2}{2 \cdot \eta_0} \cdot [ (|E_\theta(\theta, \phi)|)^2 + (|E_\phi(\theta, \phi)|)^2 ] \quad (\text{W/solid angle})$$

$$U_{1_{v,w}} := \frac{r^2}{2 \cdot \eta_0} \cdot [ (|E_{\theta 1_{v,w}}|)^2 + (|E_{\phi 1_{v,w}}|)^2 ] \quad (\text{W/solid angle})$$

$$U_{\max} := \max(U_1) \quad (\text{W/solid angle})$$

Radiated Power P<sub>rad</sub>:

$$P_{\text{rad}} := \int_0^{2 \cdot \pi} \int_0^{\frac{\pi}{2}} U(\theta, \phi) \cdot \sin(\theta) \, d\theta \, d\phi \quad (\text{W})$$

$$P_{\text{rad}} = 3.39938 \cdot 10^{-5} \quad (\text{W})$$

Directivity D<sub>o</sub>:

$$D_o := \frac{4 \cdot \pi \cdot U_{\max}}{P_{\text{rad}}} \quad (\text{dimensionless})$$

$$D_o = 1.47304 \cdot 10^2 \quad (\text{dimensionless})$$

Radiation Resistance R<sub>r</sub>:

$$R_r := \frac{2 \cdot P_{\text{rad}}}{(|I_o|)^2} \quad (\Omega)$$

$$R_r = 6.79875 \cdot 10^{-5} \quad (\Omega)$$

Gain G:

$G := .5 \cdot Do$  (dimensionless)

$G = 73.65177$  (dimensionless)

$GdB := 10 \cdot \log(G)$  (dB)

$GdB = 18.67183$  (dB)

Effective Isotropic Radiated Power EIRP:

$EIRP := Prad \cdot Do$  (W)

$EIRP = 5.0074 \cdot 10^{-3}$  (W)

Antenna Unit Polarization Vector  $\underline{\sigma}_a$ :

$\theta_p := \text{atan}\left(\frac{\sqrt{x^2 + y^2}}{z}\right)$  (radians)       $\phi_p := \text{atan}\left(\frac{y}{x}\right)$  (radians)

$\theta_p = 0.95532$  (radians)       $\phi_p = 0.7854$  (radians)

$E_x := E\theta(\theta_p, \phi_p) \cdot \cos(\theta_p) \cdot \cos(\phi_p) - E\phi(\theta_p, \phi_p) \cdot \sin(\phi_p)$  (V/m)

$E_y := E\theta(\theta_p, \phi_p) \cdot \cos(\theta_p) \cdot \sin(\phi_p) + E\phi(\theta_p, \phi_p) \cdot \cos(\phi_p)$  (V/m)

$E_z := -E\theta(\theta_p, \phi_p) \cdot \sin(\theta_p)$  (V/m)

$\sigma_a := \frac{1}{\sqrt{(|E_x|)^2 + (|E_y|)^2 + (|E_z|)^2}} \cdot \begin{pmatrix} |E_x| \\ |E_y| \\ |E_z| \end{pmatrix}$  (dimensionless)

$\sigma_a = \begin{pmatrix} -0.18825 + 0.09603j \\ 0.70255 - 0.35837j \\ -0.5143 + 0.26235j \end{pmatrix}$  (dimensionless)

Polarization Loss Factor PLF:

$$PLF := \left( \left| \frac{\sigma_w - \sigma_a}{\sigma_w + \sigma_a} \right| \right)^2 \quad (\text{dimensionless})$$

$$PLF = 0.33333 \quad (\text{dimensionless})$$

Maximum Effective Aperture  $A_{em}$ :

$$A_{em} := \frac{\lambda^2 \cdot Do \cdot 0.5 \cdot PLF}{4 \cdot \pi} \quad (\text{m}^2)$$

$$A_{em} = 2.03011 \cdot 10^{-3} \quad (\text{m}^2)$$

Maximum Effective Height  $h_{em}$ :

$$h_{em} := \sqrt{\frac{Rr \cdot A_{em}}{\eta_0}} \cdot 2 \quad (\text{m})$$

$$h_{em} = 3.82683 \cdot 10^{-5} \quad (\text{m})$$

Aperture Efficiency  $\epsilon_{ap}$ :

$$\epsilon_{ap} := \frac{A_{em}}{a1 \cdot b1} \quad (\text{dimensionless})$$

$$\epsilon_{ap} = 0.07558 \quad (\text{dimensionless})$$

THE PYRAMIDAL HORN ANTENNA FAR-FIELD ELEVATION PATTERNS

For the purpose of these far-field radiation patterns, the pyramidal horn antenna central axis is parallel to the  $E_y = 0$  grid line and the perimeter of the mouth of the horn is parallel to the  $E_x = 0$  grid line. Electric field components in the half space behind the horn's aperture are assumed to be zero.

r.l

Theta Component of Elevation Pattern

$$\phi_g := 0 \quad (\text{radians})$$

$$E_{\theta x}(\theta) := |E_{\theta}(\theta, \phi_g)| \cdot \cos(\theta)$$

$$E_{\theta y}(\theta) := |E_{\theta}(\theta, \phi_g)| \cdot \sin(\theta)$$

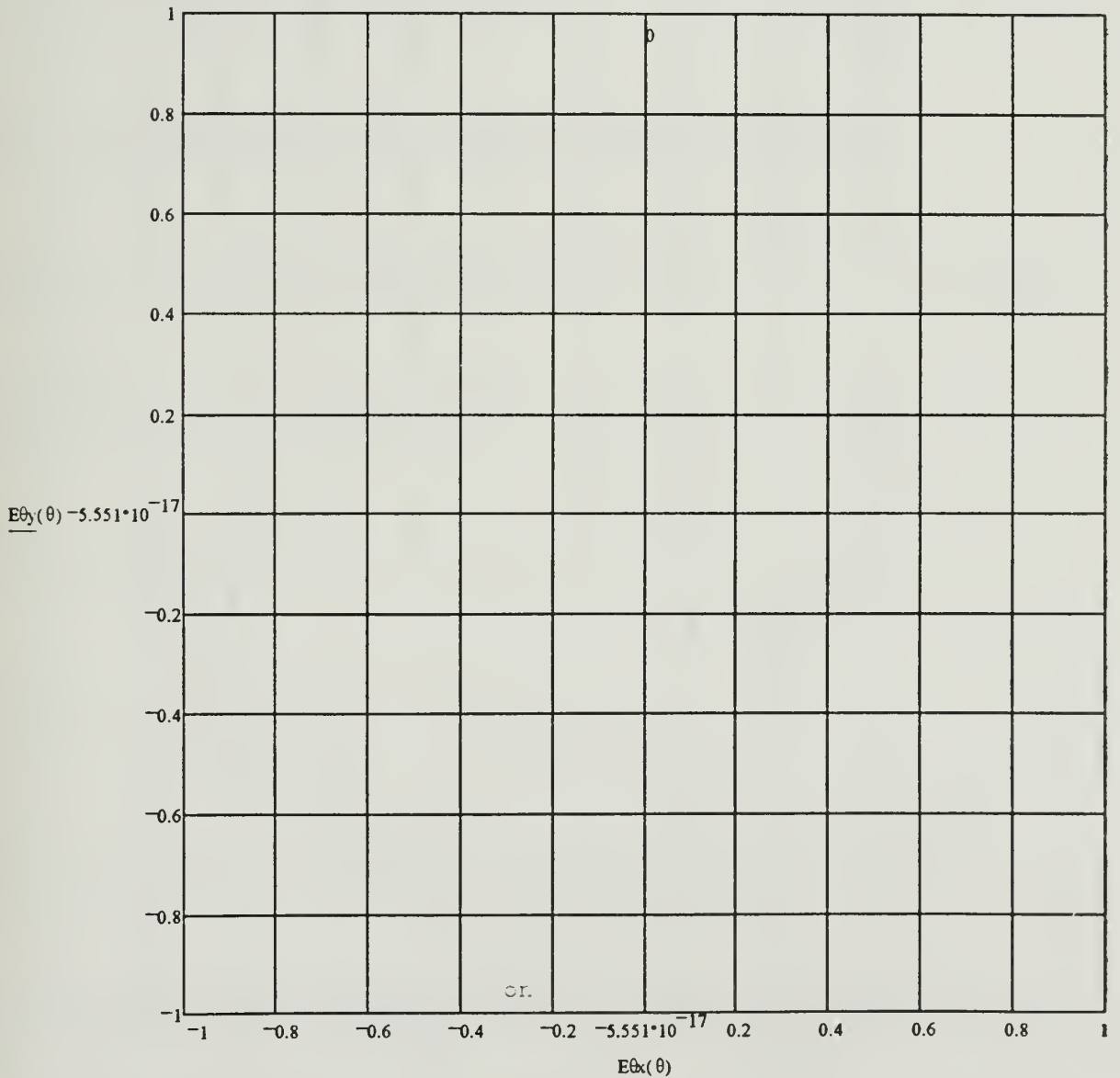

Phi Component of Elevation Pattern

$$E_{\phi x}(\theta) = |E_{\phi}(\theta, \phi_g)| \cdot \cos(\theta)$$

$$E_{\phi y}(\theta) = |E_{\phi}(\theta, \phi_g)| \cdot \sin(\theta)$$

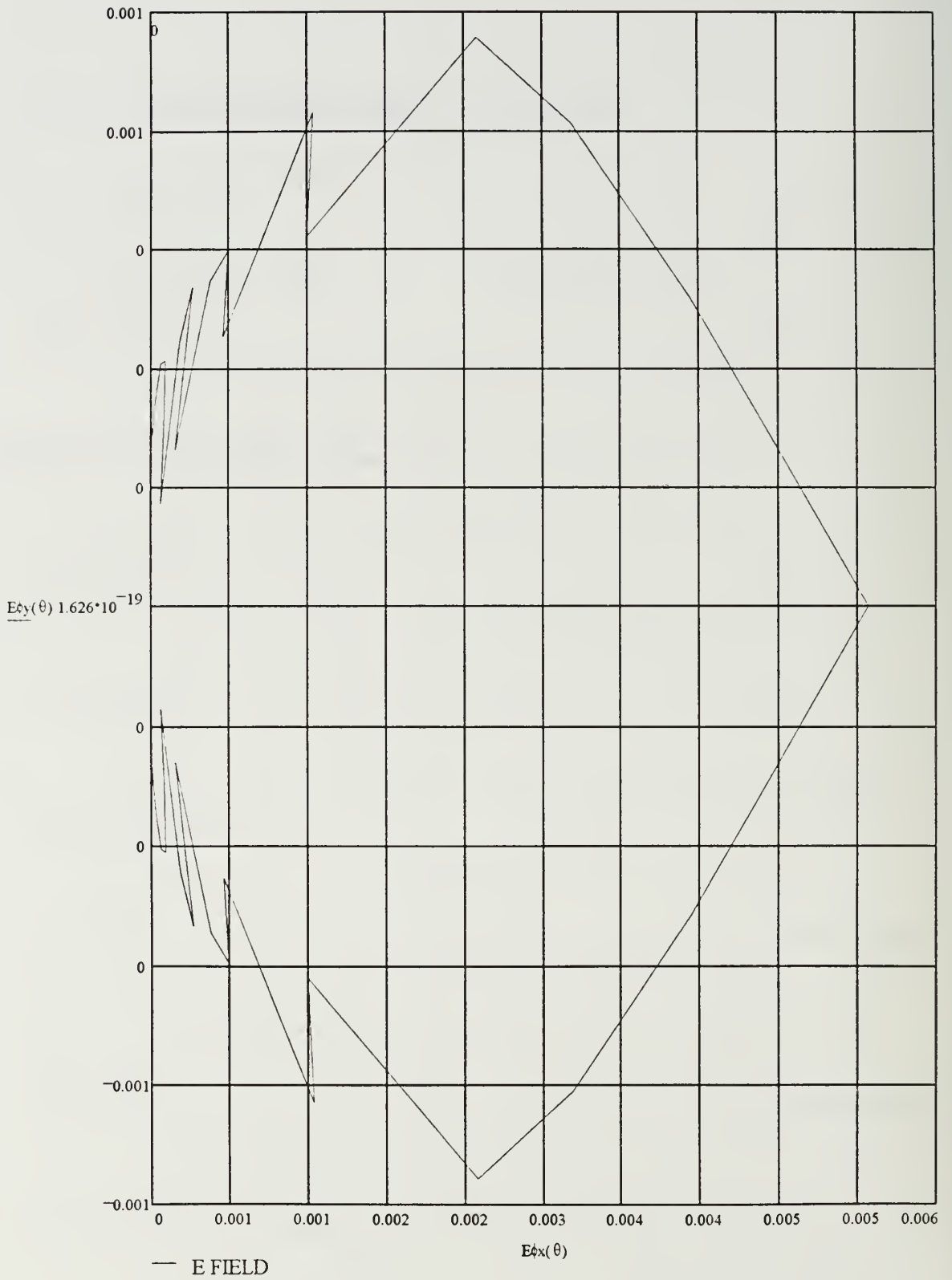

Total Elevation Pattern

$$Et(\theta, \phi) := \sqrt{E\theta(\theta, \phi)^2 + E\phi(\theta, \phi)^2}$$

$$Et_x(\theta) = ( |Et(\theta, \phi_g)| ) \cdot \cos(\theta)$$

$$Et_y(\theta) = ( |Et(\theta, \phi_g)| ) \cdot \sin(\theta)$$

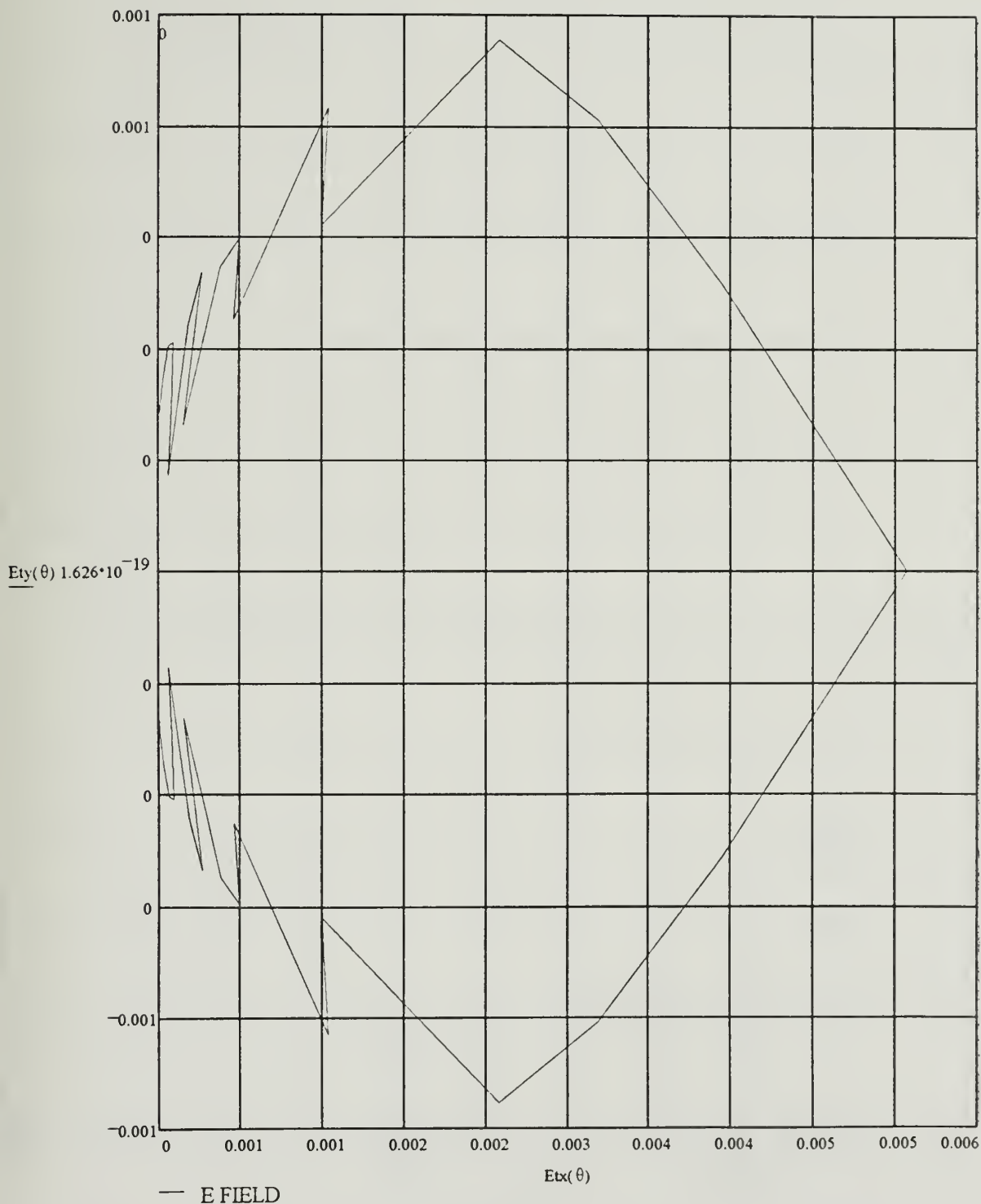



THE PYRAMIDAL HORN ANTENNA FAR-FIELD AZIMUTH PATTERNS

For the purpose of these far-field radiation patterns, the pyramidal horn central axis is perpendicular to the  $E_y = 0$  and  $E_x = 0$  grid lines.

Theta Component of Azimuth Pattern

$$\theta_g = \frac{\pi}{10} \quad (\text{Note: } \theta_g \text{ must be less than } \alpha/2 \text{ radians})$$

$$E\theta_x(\phi) := |E\theta(\theta_g, \phi)| \cdot \cos(\phi)$$

$$E\theta_y(\phi) := |E\theta(\theta_g, \phi)| \cdot \sin(\phi)$$

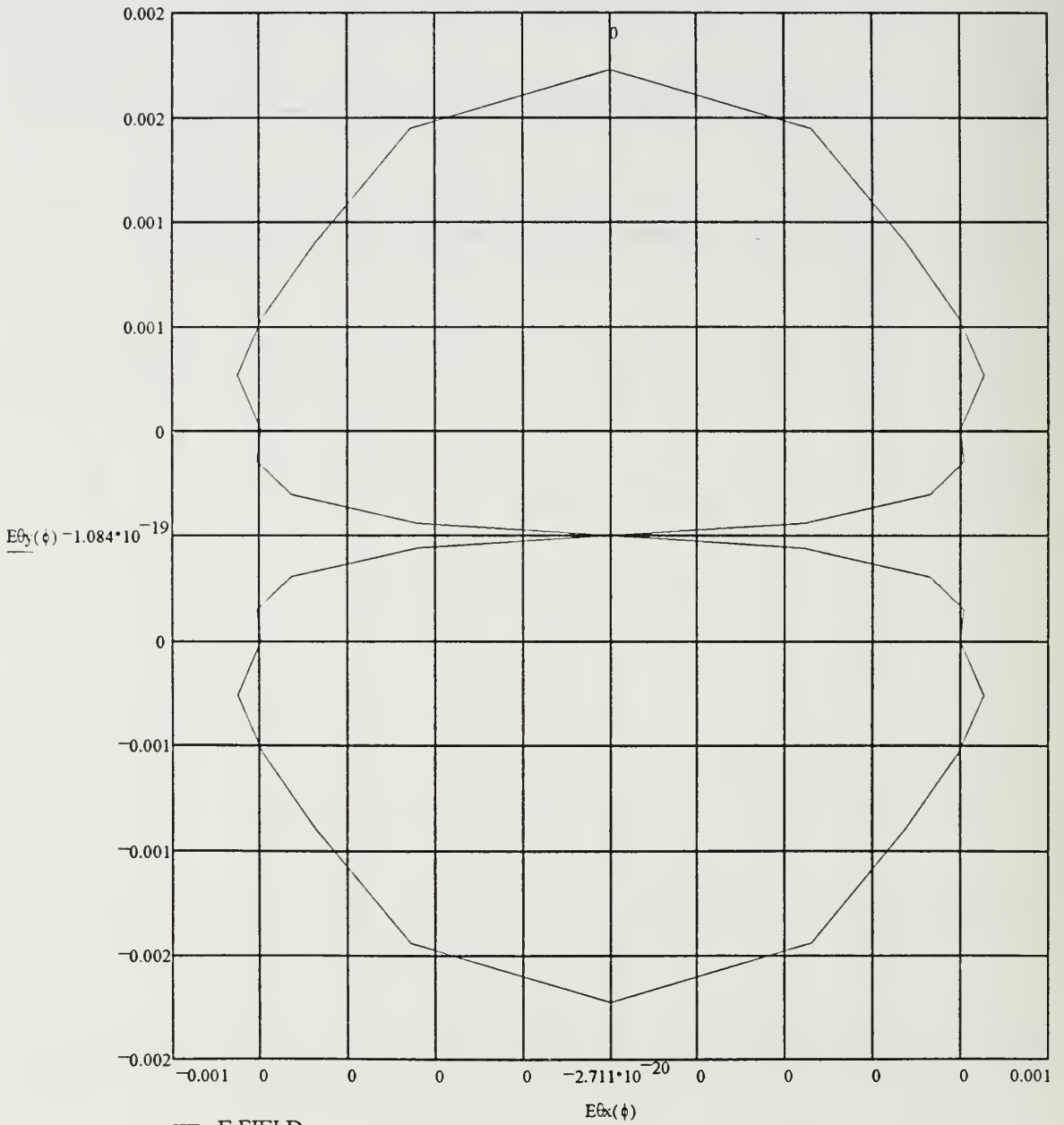

$$E_{\phi x}(\phi) := |E_{\phi}(\theta_g, \phi)| \cdot \cos(\phi)$$

$$E_{\phi y}(\phi) := |E_{\phi}(\theta_g, \phi)| \cdot \sin(\phi)$$

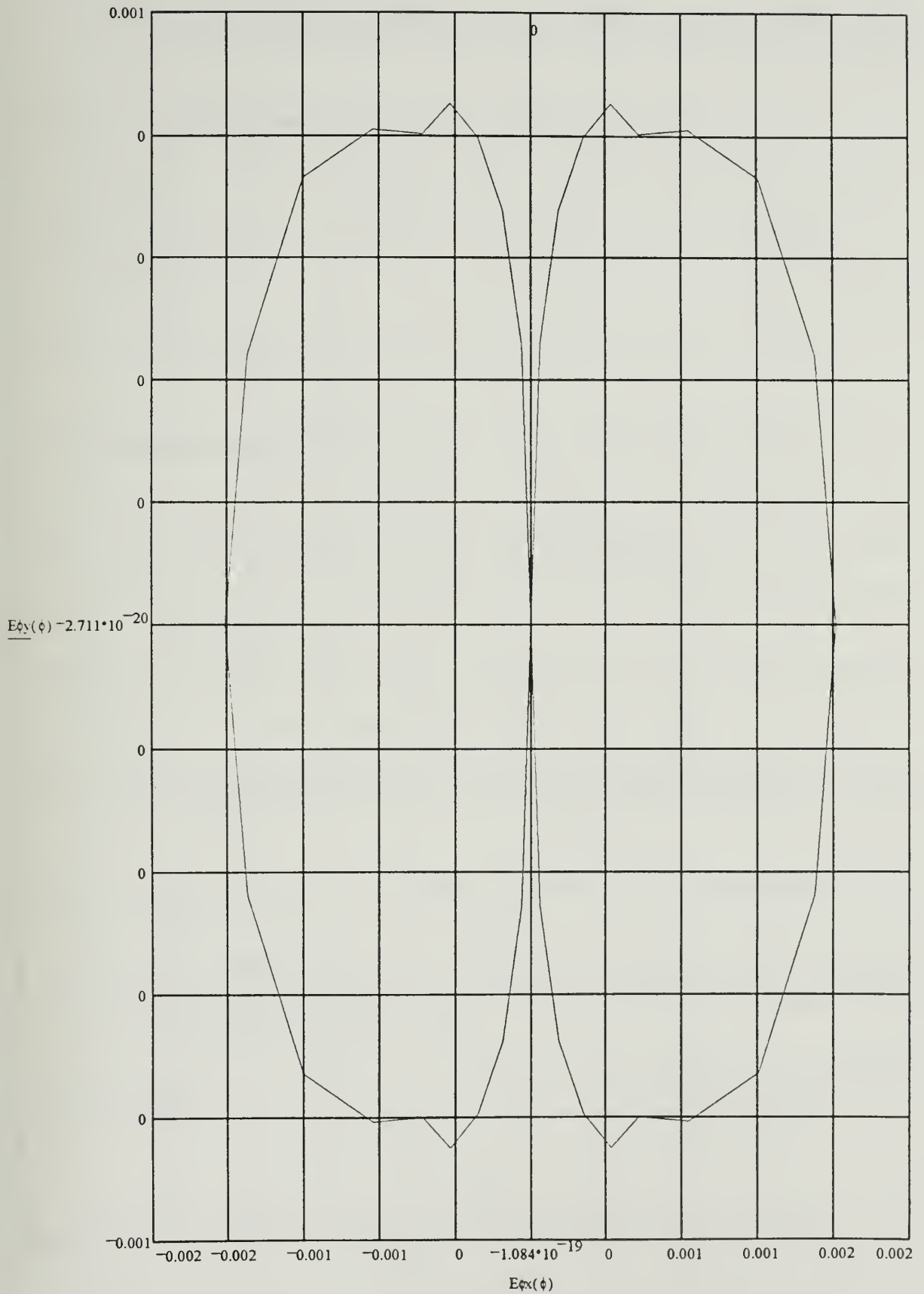

Total Azimuth Pattern

$$Et(\theta, \phi) = \sqrt{E\theta(\theta, \phi)^2 + E\phi(\theta, \phi)^2}$$

$$Et_x(\phi) = |Et(\theta_g, \phi)| \cdot \cos(\phi)$$

$$Et_y(\phi) = |Et(\theta_g, \phi)| \cdot \sin(\phi)$$

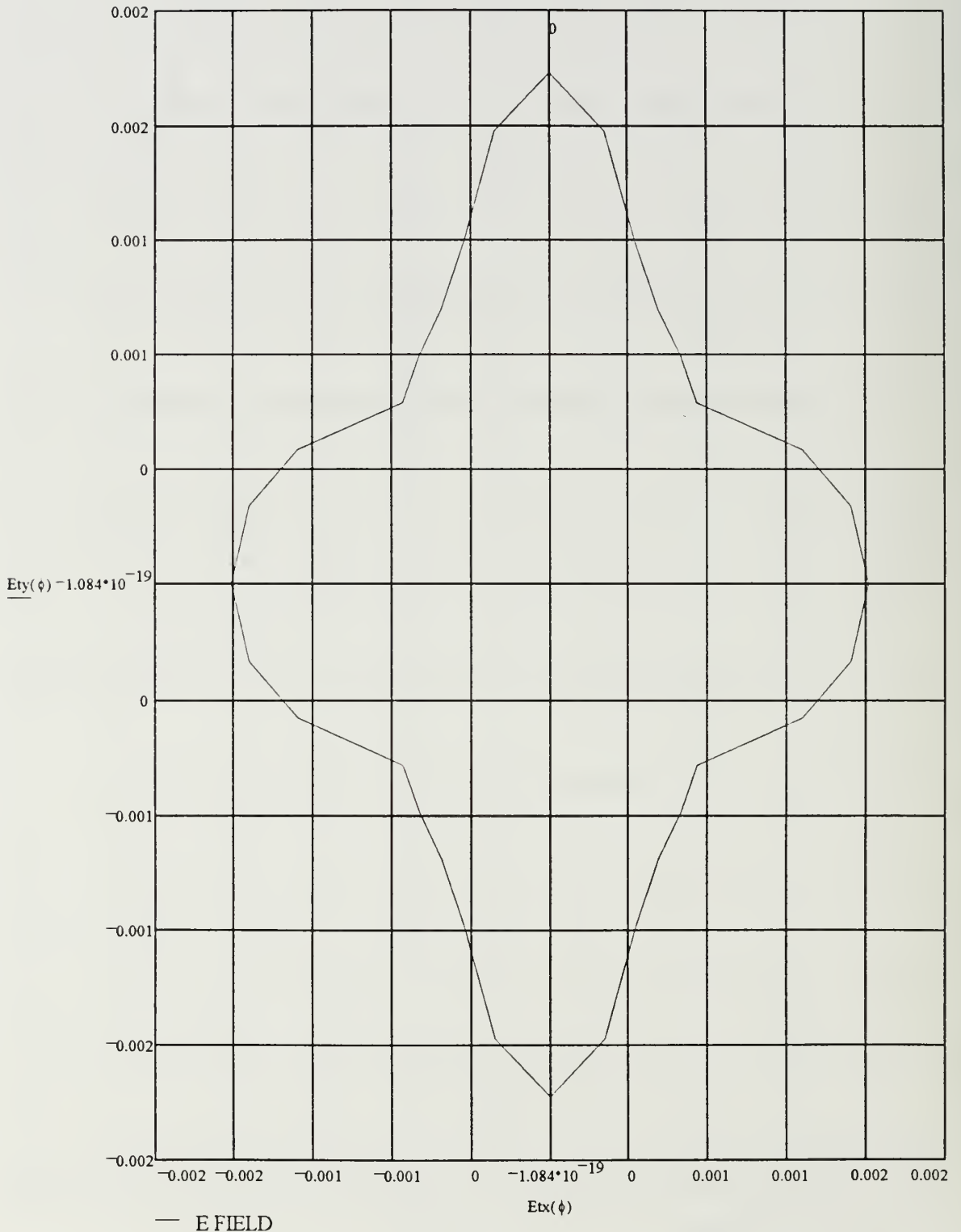

## REFERENCES

1. Dietrich, D. S., "Predicting Radiation Characteristics from Antenna Physical Dimensions," Naval Postgraduate School Technical Report NPSEC-93-009, 1992.
2. Kraus, J. D., *Antennas*, McGraw-Hill Book Company, 1988.
3. Balanis, C. A., *Antenna Theory Analysis and Design*, John Wiley & Sons, Inc., 1982.
4. Cheng, D. K., *Field and Wave Electromagnetics*, Addison-Wesley Publishing Company, 1989.
5. Stutzman, W. L., and Thiele, G. A., *Antenna Theory and Design*, John Wiley & Sons, Inc., 1981.
6. Johnson, R. C., and Jasik, H., *Antenna Engineering Handbook*, 2nd ed., McGraw-Hill Book Company, 1984.
7. Mizek, V. A., *The Beverage Antenna Handbook*, V. A. Mizek, publisher, 1987.
8. Walter, C. H., *Traveling Wave Antennas*, McGraw-Hill Book Company, 1965.
9. Belrose, J. S., Litva, J., Moss, G. E., and Stevens, E. E., "Beverage Antennas for Amateur Communications," *QST*, vol. 67, pp. 22-27, Jan. 1983.
10. Jasik, H., *Antenna Engineering Handbook*, McGraw-Hill Book Company, 1961.
11. Wolff, E. A., *Antenna Analysis*, John Wiley & Sons, 1966.
12. Chang, S., and Maddocks, H. C., "APACK, A Combined Antenna and Propagation Model," ITT Research Institute, Technical Report ESD-TR-80-102, July 1981.
13. Lo, Y. T., and Lee, S. W., *Antenna Handbook*, Van Nostrand Reinhold Company, 1988.
14. Cheo, R. S., Rumsey, V. H., and Welch, W. J., "A Solution to the Frequency-Independent Antenna Problem," *IRE Trans. on Antennas and Propagation*, vol. AP-9, pp. 527-534, Nov. 1961.
15. Corzine, R. G., and Mosko, J. A., *Four Arm Spiral Antennas*, Artech House Inc., 1990.

16. Dyson, J. D., "The Equiangular Spiral Antenna," *IRE Trans. on Antennas and Propagation*, vol. AP-7, pp. 181-187, Apr. 1959.
17. Atia, A. E., and Mei, K. K., "Analysis of Multiple-Arm Conical Log-Spiral Antennas," *IEEE Trans. on Antennas and Propagation*, vol. AP-19, pp. 320-331, May 1971.
18. Dyson, J. D., "The Unidirectional Equiangular Spiral Antenna," *IRE Trans. on Antennas and Propagation*, vol. AP-7, pp. 329-334, Oct. 1959.
19. Balanis, C. A., *Advanced Engineering Electromagnetics*, John Wiley & Sons, Inc., 1989.
20. Schorr, M. G., and Beck, Jr., F. J., "Electromagnetic Field of the Conical Horn," *J. of Applied Physics*, vol. 21, pp. 795-801, Aug. 1950.
21. Hamid, M. A. K., "Diffraction by a Conical Horn," *IEEE Trans. on Antennas and Propagation*, vol. AP-26, pp. 520-528, Sep. 1968.
22. Southworth, G. C., and King, A. P., "Metal Horns as Directive Receivers of Ultra-Short Waves," *IRE Proc.*, vol. 27, pp. 95-102, Feb. 1939.
23. *Handbook of Mathematical Functions with Formulas, Graphs, and Mathematical Tables*. M. Abramowitz and I. A. Stegun, eds., National Bureau of Standards, Dec. 1972.

INITIAL DISTRIBUTION LIST

1. Defense Technical Information Center 2  
Cameron Station  
Alexandria, VA 22304-6145
  
2. Library, Code 52 2  
Naval Postgraduate School  
Monterey, CA 93943-5002
  
3. Chairman, Code EC 1  
Department of Electrical and Computer Engineering  
Naval Postgraduate School  
Monterey, CA 93943-5002
  
4. Professor R. Clark Robertson, Code EC/Rc 1  
Department of Electrical and Computer Engineering  
Naval Postgraduate School  
Monterey, CA 93943-5002
  
5. Lieutenant Frank Kragh, Code EC/Kh 1  
Department of Electrical and Computer Engineering  
Naval Postgraduate School  
Monterey, CA 93943-5002
  
6. LCDR Donald Gerry 1  
90 Jefferson Rd.  
Bourne, MA 02532
  
7. NAVMARINTCEN 4  
ATTN: Mr. Ron Ullom  
DI433  
4301 Suitland  
Washington D.C. 20395-5020
  
8. Professor M.A. Morgan, Code EC/Mw 1  
Department of Electrical and Computer Engineering  
Naval Postgraduate School  
Monterey, CA 93943-5002
  
9. Professor David Jenn, Code EC/Jn 1  
Department of Electrical and Computer Engineering  
Naval Postgraduate School  
Monterey, CA 93943-5002







DUDLEY KNOX LIBRARY



3 2768 00331624 1